



Cert. No. LRQ 0963008

ISO 9001

spirax sarco

SDCV7

TI-P601-06
ST Issue 5

Carbon Steel

Split Disc Check Valve (DIN/PN Flanges)

Description

A range of carbon steel split disc check valves in a wafer pattern suitable for fitting between PN16 and PN40 flanges. Their function is to prevent reverse flow on a wide variety of fluids for applications in process lines, hot water systems, steam and condensate systems. The face-to-face dimension of the SDCV7 conforms to API 594 and seat leakage to API 598. As standard valves have a metal-to-metal seat. A Fluoroelastomer soft seat and heavy spring are also available.

Operation

A split disc check valve is opened by the pressure of the fluid and closed by the spring as soon as the flow ceases and before the reverse flow occurs.

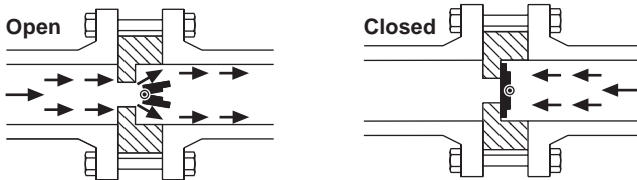

Standards

This product fully complies with the requirements of the European Pressure Equipment Directive 97/23/EC and carries the CE mark when so required.

Standard shut-off

Metal-to-metal seat leakage is tested to API 598.

Certification

The product is available with certification to EN 10204 3.1.B
Note: All certification/inspection requirements must be stated at the time of order placement.

Size and pipe connections

DN50, DN80, DN100, DN150, DN200, DN250 and DN300.
Suitable for installation between PN16 and PN40 flanges.

Pressure/temperature limits

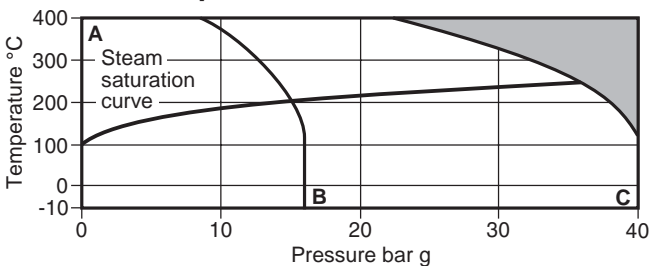

The product **must not** be used in this region.

A - B EN 1092 PN16 flanges **A - C** EN 1092 PN40 flanges

Body design conditions		PN40	
PMA	Maximum allowable pressure	40 bar g @ 100°C	
TMA	Maximum allowable temperature	400°C	
Minimum allowable temperature	Metal seat	-10°C	
	Fluoroelastomer soft seat	-10°C	
PMO	Maximum operating pressure	40 bar g @ 100°C	
TMO	Maximum operating temperature	Metal seat	400°C @ 22 bar g
		Fluoroelastomer soft seat	200°C @ 38 bar g
Minimum operating temperature	Metal seat	-10°C	
	Fluoroelastomer soft seat	-10°C	

Designed for a maximum cold hydraulic test pressure of 60 bar g

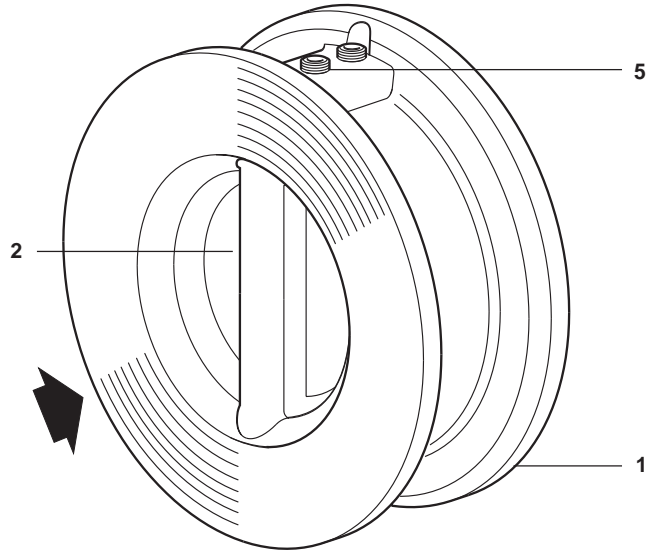

Note: Item 6 cannot be illustrated.

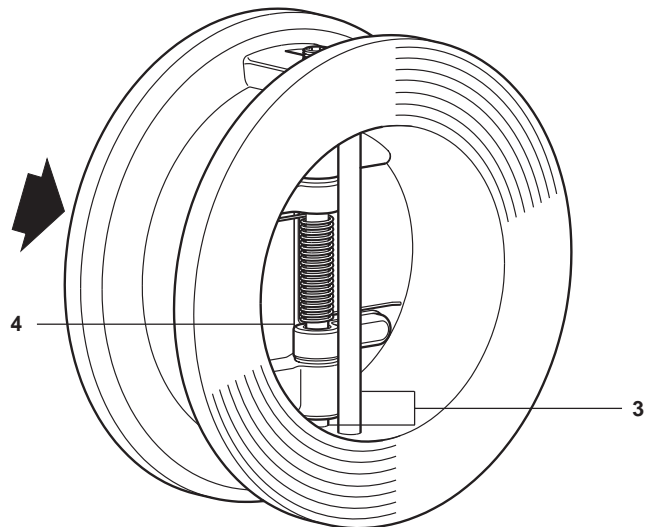

Materials

No.	Part	Material	
* 1	Body	Carbon steel	ASTM A216 WCB
2	Plate	Austenitic stainless steel	ASTM A351 CF8M
3	Hinge/stop pin	Austenitic stainless steel	AISI 316
4	Spring	Nickel alloy	Inconel-X
5	Retainer plug	Austenitic stainless steel	AISI 316
* 6	Soft seat	Fluoroelastomer (optional)	Fluoroelastomer

* Valve bodies that are marked with a 'V' - have a Fluoroelastomer seating face.
Valve bodies that are marked with a 'H' - have heavy springs 0.45 bar g (450 mb)

Note: A range of alternative body, plate and component materials are available to satisfy special applications.
Please contact Spirax Sarco for further information on availability and how to order.

Dimensions approximate in mm

	PN16 Ø A	PN40 Ø A	B	Ø C	Ø D
DN50	109	109	60	40	57.0
DN80	144	144	73	51	87.0
DN100	164	170	73	89	113.0
DN150	220	226	98	140	166.0
DN200	275	293	127	171	206.5
DN250	331	355	146	235	260.0
DN300	386	420	181	260	300.0

Weights approximate kg

	PN16	PN40
DN50	2.7	2.7
DN80	6.8	6.8
DN100	8.6	8.6
DN150	17.0	25.0
DN200	31.0	36.0
DN250	52.0	64.0
DN300	97.0	98.0

K_v values

DN	50	80	100	150	200	250	300
K _v	40	111	226	611	1 188	2 205	3 299

For conversion: Cv (UK) = Kv x 0.963 Cv (US) = Kv x 1.156

Opening pressures in mbar

Differential pressures with zero flow. → Flow direction

	DN50	DN80	DN100	DN150	DN200	DN250	DN300
→	30	30.0	26	27	16	16	17
↑	48	45.5	43	43	39	40	46

Note: with a heavy spring fitted the opening pressure is 0.45 bar g (450 mb).

Pressure loss diagram

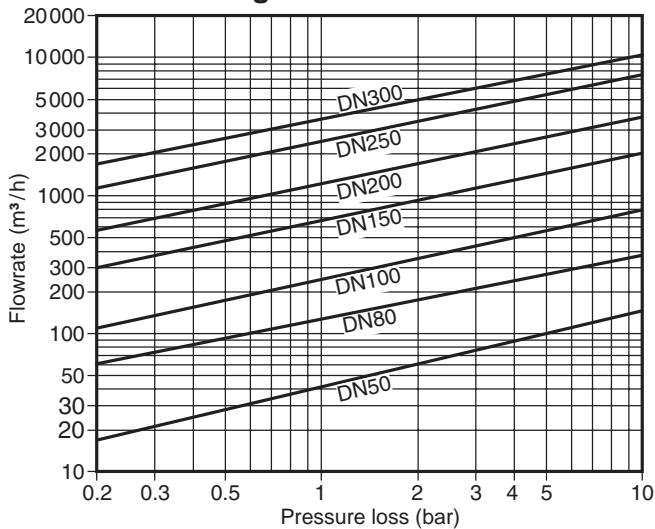

Pressure loss diagram with the valve open at 20°C. The values indicated are applicable to spring loaded valves with horizontal flow. With vertical flow, insignificant deviations occur only within the range of partial opening.

The curves given in the chart are valid for water at 20°C. To determine the pressure drop for other fluids the equivalent water volume flowrate must be calculated and used in the graph.

$$\dot{V}_w = \sqrt{\frac{\rho}{1000}} \times \dot{V}$$

Where: \dot{V}_w = Equivalent water volume flow in l/s or m³/h

ρ = Density of fluid kg/m³

\dot{V} = Volume of fluid l/s or m³/h

Pressure loss information for steam, compressed air and gases is available from Spirax Sarco.

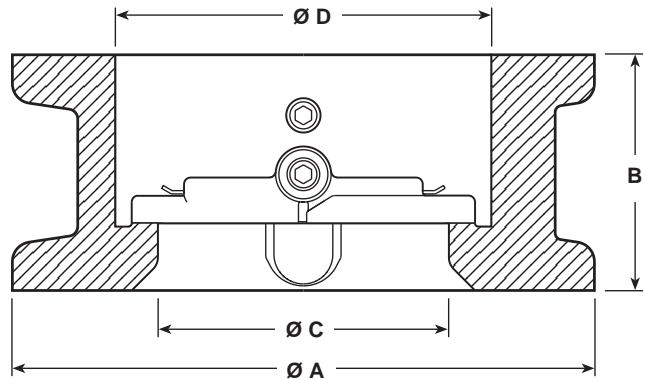

How to order

Example: 1 off Spirax Sarco SDCV7 having a carbon steel body (WCB) for installation between DN150, PN40 flanges. Complete with EN 10204 3.1.B certification for the body.

Safety information, installation and maintenance

For full details see the Installation and Maintenance Instructions (IM-P601-03) supplied with the product.

Note: The SDCV7 is not suitable for heavy pulsating flows (compressors) or vertical down flows.

Flanges, bolts (or studs), nuts and joint gaskets are to be provided by the installer.

Spare parts

The spare parts available are shown in solid outline. Parts drawn in broken line are not supplied as spares.

Available spares

Overhaul kit 2 (2 off), 3 (2 off), 4

How to order spares

Always order spares by using the description given in the column headed 'Available spares' and state the size and type of check valve.

Example: 1 - Overhaul kit for a DN200 SDCV7 split disc check valve.

