



Cert. No. LRQ 0963008

ISO 9001

spirax sarco

SDCV3

TI-P601-04
ST Issue 5

Carbon Steel

Split Disc Check Valve (ANSI/JIS/KS Flanges)

Description

A range of carbon steel split disc check valves in a wafer pattern suitable for fitting between ANSI Class 150, ANSI Class 300 and JIS/KS 10K and 20K flanges. Their function is to prevent reverse flow on a wide variety of fluids for applications in process lines, hot water systems, steam and condensate systems. The face-to-face dimension of the SDCV3 conforms to API 594 and seat leakage to API 598. As standard valves have a metal-to-metal seat. A Fluoroelastomer soft seat and heavy spring are also available.

Operation

A split disc check valve is opened by the pressure of the fluid and closed by the spring as soon as the flow ceases and before the reverse flow occurs.

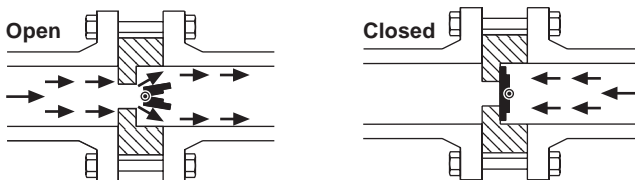

Standards

This product fully complies with the requirements of the European Pressure Equipment Directive 97/23/EC and carries the CE mark when so required.

Standard shut-off

Metal-to-metal seat leakage is tested to API 598.

Certification

The product is available with certification to EN 10204 3.1.B
Note: All certification/inspection requirements must be stated at the time of order placement.

Size and pipe connections

DN50, DN80, DN100, DN150, DN200, DN250 and DN300.
Suitable for installation between the following flanges:
ANSI B 16.5 class 150 and 300, JIS/KS 10K and 20K.

Pressure/temperature limits

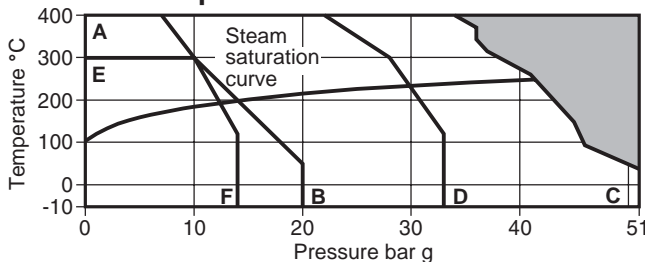

The product **must not** be used in this region.

A - B ANSI 150 flanges **E - F** JIS/KS 10K flanges
A - C ANSI 300 flanges **A - D** JIS/KS 20K flanges

| Body design conditions | | ANSI 300 |
|--------------------------------|-------------------------------|------------------|
| PMA | Maximum allowable pressure | 51 bar g @ 38°C |
| TMA | Maximum allowable temperature | 400°C |
| Minimum allowable temperature | Metal seat | -10°C |
| | Fluoroelastomer soft seat | -10°C |
| PMO Maximum operating pressure | | 51 bar g @ 38°C |
| TMO operating temperature | Maximum Metal seat | 400°C @ 34 bar g |
| | Fluoroelastomer soft seat | 200°C @ 44 bar g |
| Minimum operating temperature | Metal seat | -10°C |
| | Fluoroelastomer soft seat | -10°C |

Designed for a maximum cold hydraulic test pressure of 76 bar g

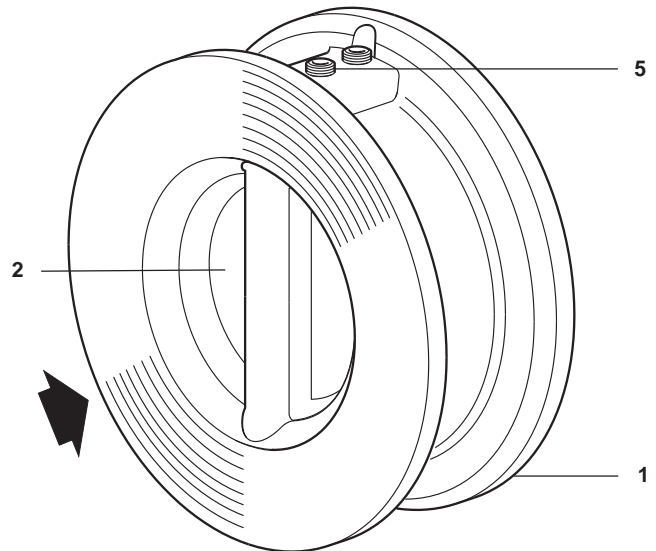

Note: Item 7 is not shown and item 6 cannot be illustrated.

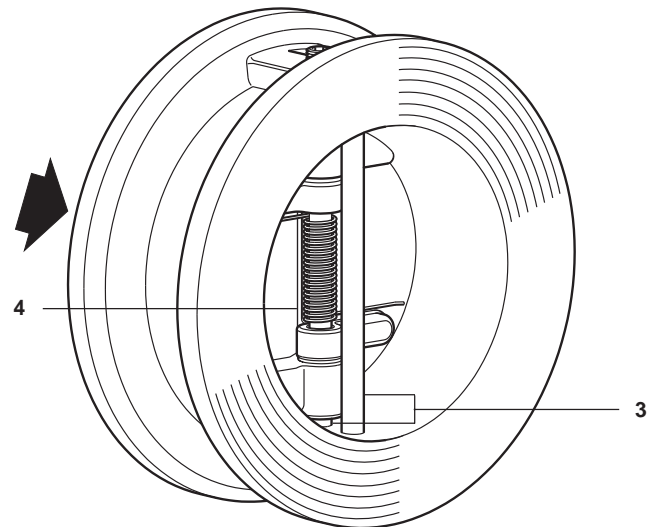

Materials

| No. Part | Material |
|----------|-------------------------------------------------------|
| * 1 | Body Carbon steel ASTM A216 WCB |
| 2 | Plate Austenitic stainless steel ASTM A351 CF8M |
| 3 | Hinge/stop pin Austenitic stainless steel AISI 316 |
| 4 | Coil spring Nickel alloy Inconel-X |
| 5 | Retainer plug Austenitic stainless steel AISI 316 |
| * 6 | Soft seat Fluoroelastomer (optional) Fluoroelastomer |
| 7 | Eye bolt Carbon steel (DN150 to DN300, ANSI 600 only) |

* Valve bodies that are marked with a 'V' - have a Fluoroelastomer seating face. Valve bodies that are marked with a 'H' - have heavy springs 0.45 bar g (450 mb).

Note: A range of alternative body, plate and component materials are available to satisfy special applications. Please contact Spirax Sarco for further information on availability and how to order.

Dimensions approximate in mm

| | ANSI 150 Ø A | ANSI 300 Ø A | JIS/KS 10K Ø A | JIS/KS 20K Ø A | B | Ø C | Ø D |
|-------|-----------------|-----------------|-------------------|-------------------|-----|-----|-------|
| DN50 | 105 | 111 | 101 | 101 | 60 | 40 | 57.0 |
| DN80 | 137 | 149 | 131 | 137 | 73 | 51 | 87.0 |
| DN100 | 175 | 181 | 156 | 162 | 73 | 89 | 113.0 |
| DN150 | 222 | 251 | 217 | 235 | 98 | 140 | 166.0 |
| DN200 | 279 | 308 | 267 | 279 | 127 | 171 | 206.5 |
| DN250 | 340 | 362 | 330 | 353 | 146 | 235 | 260.0 |
| DN300 | 410 | 422 | 375 | 403 | 181 | 260 | 300.0 |

Weights approximate in kg

| | ANSI 150 | ANSI 300 | JIS/KS 10K | JIS/KS 20K |
|-------|----------|----------|------------|------------|
| DN50 | 2.7 | 2.7 | 2.5 | 2.5 |
| DN80 | 6.8 | 6.8 | 6.5 | 6.6 |
| DN100 | 8.6 | 8.6 | 8.1 | 8.2 |
| DN150 | 17.0 | 25.0 | 16.0 | 16.2 |
| DN200 | 31.0 | 36.0 | 29.0 | 29.2 |
| DN250 | 52.0 | 64.0 | 48.5 | 49.0 |
| DN300 | 97.0 | 98.0 | 91.0 | 92.0 |

K_v values

| DN | 50 | 80 | 100 | 150 | 200 | 250 | 300 |
|----------------|----|-----|-----|-----|-------|-------|-------|
| K _v | 40 | 111 | 226 | 611 | 1 188 | 2 205 | 3 299 |

For conversion: C_v (UK) = K_v x 0.963 C_v (US) = K_v x 1.156

Opening pressures in mbar

Differential pressures with zero flow. → Flow direction

| | DN50 | DN80 | DN100 | DN150 | DN200 | DN250 | DN300 |
|---|------|------|-------|-------|-------|-------|-------|
| → | 30 | 30.0 | 26 | 27 | 16 | 16 | 17 |
| ↑ | 48 | 45.5 | 43 | 43 | 39 | 40 | 46 |

Note: with a heavy spring fitted the opening pressure is 0.45 bar g (450 mb).

Pressure loss diagram

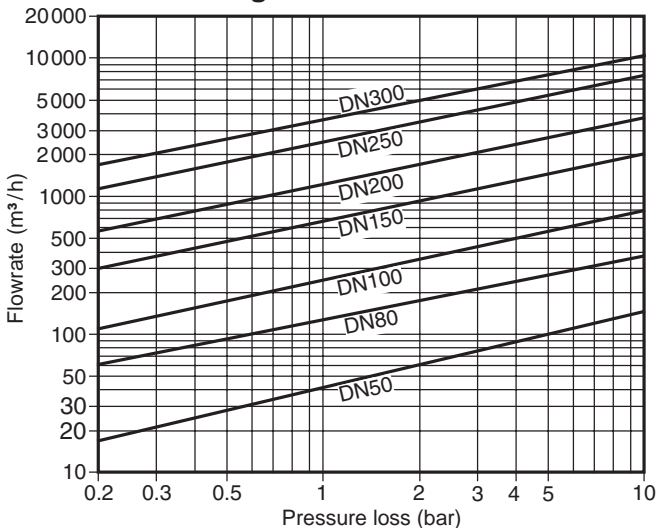

Pressure loss diagram with the valve open at 20°C. The values indicated are applicable to spring loaded valves with horizontal flow. With vertical flow, insignificant deviations occur only within the range of partial opening. The curves given in the chart are valid for water at 20°C. To determine the pressure drop for other fluids the equivalent water volume flowrate must be calculated and used in the graph.

$$\dot{V}_w = \sqrt{\frac{\rho}{1000}} \times \dot{V}$$

Where: \dot{V}_w = Equivalent water volume flow in l/s or m³/h
 ρ = Density of fluid kg/m³
 \dot{V} = Volume of fluid l/s or m³/h

Pressure loss information for steam, compressed air and gases is available from Spirax Sarco.

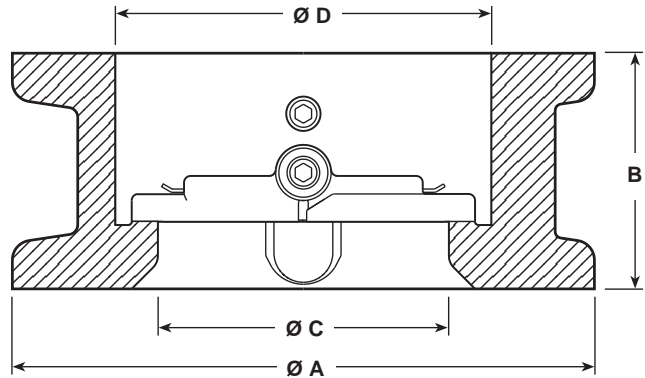

How to order

Example: 1 off Spirax Sarco SDCV3 having a carbon steel body for installation between DN150, ANSI Class 150 flanges. Complete with EN 10204 3.1.B certification for the body.

Safety information, installation and maintenance

For full details see the Installation and Maintenance Instructions (IM-P601-03) supplied with the product.

Note: The SDCV3 is not suitable for heavy pulsating flows (compressors) or vertical down flows. Flanges, bolts (or studs), nuts and joint gaskets are to be provided by the installer.

Spare parts

The spare parts available are shown in solid outline. Parts drawn in broken line are not supplied as spares.

Available spares

Overhaul kit 2 (2 off), 3 (2 off), 4

How to order spares

Always order spares by using the description given in the column headed 'Available spares' and state the size and type of check valve.

Example: 1 - Overhaul kit for a DN200 SDCV3 split disc check valve.

