



Cert. No. LRQ 0963008

ISO 9001

spirax sarco

TI-P403-91
 AB Issue 2

BC3150 Blowdown Controller

Description

The BC3150 is a blowdown controller for steam boilers. It controls TDS (total dissolved solids – salts in solution) by opening and closing a blowdown valve. It works in conjunction with a Spirax Sarco conductivity sensor, a boiler blowdown valve or condensate dump valve.

The product can be panel, DIN rail or chassis mounted and powered by a 99 – 264 Vac mains supply.

The front panel has a 3 digit LCD and a five-button keypad.

The product has no battery. The programmed settings are held in non-volatile memory (Flash) and are written to after changing a parameter and pressing the OK key.

Principal features:

- Blowdown controller with temperature compensation.
- Type approved as a TDS limiter and controller.
- Works with CP10, CP30 or CP32 conductivity probes.
- Wide range: 1-9990 $\mu\text{S}/\text{cm}$ or ppm – (x1, x 10, x 100 x 1000).
- LCD display with direct probe condition indicator.
- Infrared communications.

Approvals

This product complies with the Electromagnetic Compatibility Directive 2004 / 108 / EC and all its requirements.

The BC3150 is suitable for Class A Environments (e.g. industrial). A fully detailed EMC assessment has been made and has the reference number UK Supply BH BC3150 2008.

The BC3150 complies with the Low Voltage Directive by meeting the standards of:

- EN 61010-1:2001 safety requirements for electrical equipment for measurement, control, and laboratory use.

The BC3150 has been type-tested as a TDS controller and limiter by meeting the standard:

- Vd TÜV Equipment for Water Control 100 (07.2006).
- The BC3150 is UL listed (open).

Function

All ranges and operating parameters are selected using the software menu.

Commissioning is carried out using the two lower buttons.

Once fully commissioned, the TDS value is displayed in $\mu\text{S}/\text{cm}$ (or ppm if selected).

If the water conductivity exceeds the Set Point level, the TDS value shown on the display will alternate with 'bld', and the valve relay will be energised until the conductivity drops below 5% of full scale (FS) below the set point.

If the water conductivity exceeds the alarm level, the TDS value will alternate with 'AL', and the valve relay will be energised until the conductivity drops 3% (FS) below the alarm level.

If the system is carrying out a purge, The TDS value will alternate with 'Pur', and the valve relay will be energised until the conductivity drops 5% (FS) below the set point.

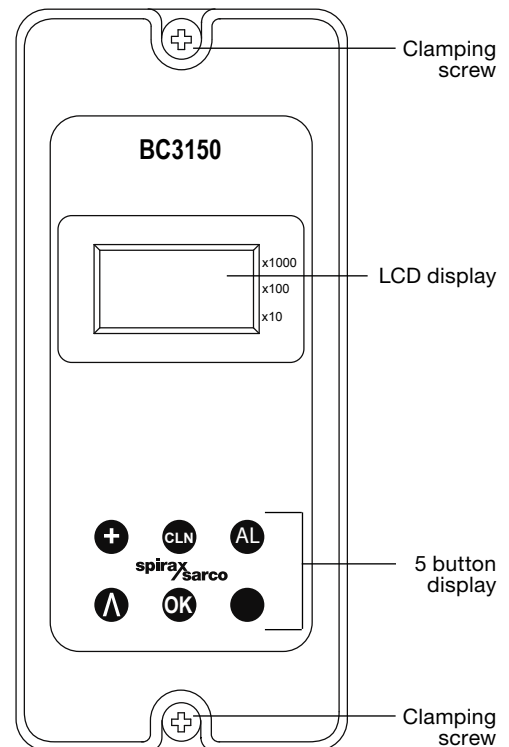

Inputs

The BC3150 can accept a signal from a Spirax Sarco conductivity probe (CP10, CP30, or CP32).

A Pt100 temperature sensor may be connected to provide temperature compensation (2% / °C). This is recommended if the boiler is working at varying pressures, or for other applications, such as condensate monitoring or coil boilers, where the temperature may vary. If a Pt100 is not fitted, the product uses a default temperature of 184°C (10 bar g).

Outputs

Pulsed output - For smaller boilers where the capacity of the blowdown valve is relatively high compared to the boiler size, the blowdown may be set to pulsed, rather than continuous output, opening for 10 seconds, and closing for 20 seconds. This slows the rate at which the boiler water is removed so that the level is not unduly affected, avoiding the risk of triggering a low water alarm.

Other features

To prevent unwanted or inadvertent changes being made, all commissioning parameters are protected with a pass code.

The BC3150 can communicate via an infrared link between adjacent controllers.

This feature enables the parameters of this product (OEM) to be passed to a product fitted with RS485 (user).

The BC3150 is always an IR slave – No set-up or adjustment is needed.

An isolated 4 - 20 mA output is provided as standard, and may be used for remote display of the TDS level or as an output to a computerised management system.

Technical data BC3150

Power supply	Mains voltage range	99 Vac to 264 Vac at 50/60 Hz			
	Power consumption	7.5 W (maximum)			
Environmental	General	Indoor use only			
	Maximum altitude	2 000 m (6 562 ft) above sea level			
	Ambient temperature limits	0 - 55°C			
	Maximum relative humidity	80% up to 31°C decreasing linearly to 50% at 40°C			
	Overvoltage category	III			
	Pollution degree	2 (as supplied)			
	Enclosure rating (front panel only)	NEMA type 4 hose down only (UL approval) and IP65 (verified by TRAC Global)			
	LVD (safety)	Electrical safety EN 61010-1 UL61010-1 CAN/CSA C22.2 No. 61010-1			
	EMC	Immunity/Emissions	Suitable for heavy industrial locations		
	Enclosure	Material	Polycarbonate		
	Front panel	Material	Silicone rubber, 60 shore.		
	Solder	Tin/lead (60/40%)			
	Cable / wire and connector data	Mains and signal connector	Termination	Rising clamp plug-in terminal blocks with screw connectors. Caution: Use only the connectors supplied by Spirax Sarco Ltd. - Safety and Approvals may be compromised otherwise.	
Cable size			0.2 mm ² (24 AWG) to 2.5 mm ² (12 AWG).		
Stripping length			5 - 6 mm		
TDS probe		Type	High temperature		
		Shield type	Screened		
		Gauge	1 - 1.5 mm ² (18 - 16 AWG)		
		Maximum length	0 - 9.99 range - 10 metres 0 - 99.90 range - 30 metres 0-999.0 range and 0-9990 ranges - 100 metres		
Pt100 probe cable / wire		Recommended type	Prysmian (Pirelli) FP200, Delta Crompton Firetuf OHLS		
		Type	High temperature, twisted		
		Shield type	Screened		
		Number of cores	3		
		Gauge	1 - 1.5 mm ² (18 - 16 AWG)		
		Maximum length	100 m (328 ft)		
		Recommended type	Various		
		4 - 20 mA output cable / wires	Type	Twisted pair	
			Shield type	Screened	
			Number of pairs	1	
			Gauge	0.23 - 1 mm ² (24 - 18 AWG)	
			Maximum length	100 m (328 ft)	
Recommended type		Various			

Technical data BC3150 (continued)

Input technical data	Water conductivity	Probe types	CP10, CP30 and CP32
		Ranges	0 – 9.99 ppm or $\mu\text{S/cm}$
			0 – 99.9 ppm or $\mu\text{S/cm}$
			0 – 999 ppm or $\mu\text{S/cm}$
			0 – 9990 ppm or $\mu\text{S/cm}$
		Accuracy	$\pm 2.5\%$ FSD (possibly > in high EM locations)
		$\mu\text{S/cm}$ to ppm conversion	0.7
	Neutralising factor	0.7	
	Resolution	0.1% FSD	
	Drive:	ac – 4 wires	
	Temperature compensation (TC)	Sensor type	Pt100 – Class B or better
		Range	0 - 250°C (With Pt100 not fitted – user programmed temperature 100 - 250°C, 1°C steps)
		Accuracy	$\pm 2.5\%$ FSD – system accuracy $\pm 5\%$
Resolution		0.1% FSD	
Drive:		dc – 3 wires	
Output technical data	Probe cleaning	Maximum voltage	32 Vdc
		Drive	Pulsed (1 second on, 1 second off)
		Time	20 seconds
	4 - 20 mA	Minimum current	0 mA
		Maximum current	20 mA
		Open circuit voltage (maximum)	19 Vdc
		Resolution	0.1% FSD
		Maximum output load	500 ohm
		Isolation	100 V
		Output rate	10 / second
	Relays	Contacts	2 x single pole changeover relays (SPCO)
		Voltage ratings (maximum)	250 Vac
		Resistive load	3 amp @ 250 Vac
		Inductive load	1 amp @ 250 Vac
		ac motor load	$\frac{1}{4}$ HP (2.9 amp) @ 250 Vac
			$\frac{1}{10}$ HP (3 amp) @ 120 Vac
		Pilot duty load	C300 (2.5 amp) - control circuit/coils
		Electrical life (operations)	3×10^5 or greater depending on load
		Mechanical life (operations)	30×10^6

Safety information, installation and maintenance

Warning: This document does not contain sufficient information to install the unit safely. The unit operates at a potentially fatal mains voltage. Before attempting to install the unit read the Installation and Maintenance Instructions supplied with it.

Caution: before installing and connecting the power ensure there is no condensation within the unit. The product may be installed on a DIN rail, on a chassis plate, or in a panel cutout. A bezel is supplied.

The product must be installed in a suitable industrial control panel or fireproof enclosure to provide impact and environmental protection. A minimum of IP54 (EN 60529) or Type 3, 3S, 4, 4X, 6, 6P and 13 (UL50/NEMA 250) is required. Spirax Sarco can provide suitable plastic or metal enclosures

Do not install the product outdoors without additional weather protection.

Do not attempt to open the product - it is sealed and has no replaceable parts or internal switches.

Do not cover or obstruct the infrared beam between products.

In the UK, your attention is drawn to IEE Regulations (BS 7671). Elsewhere, other regulations will normally apply.

All wiring materials and methods shall comply with relevant EN and IEC standards where applicable.

No special servicing, preventative maintenance or inspection of the product is required.

Boiler water level controls and level alarms do, however, require testing and inspection. General guidance is given in Health and Safety Executive Guidance Note PM5.

Dimensions / weight (approximate) in mm and g.

Weight 475 g.

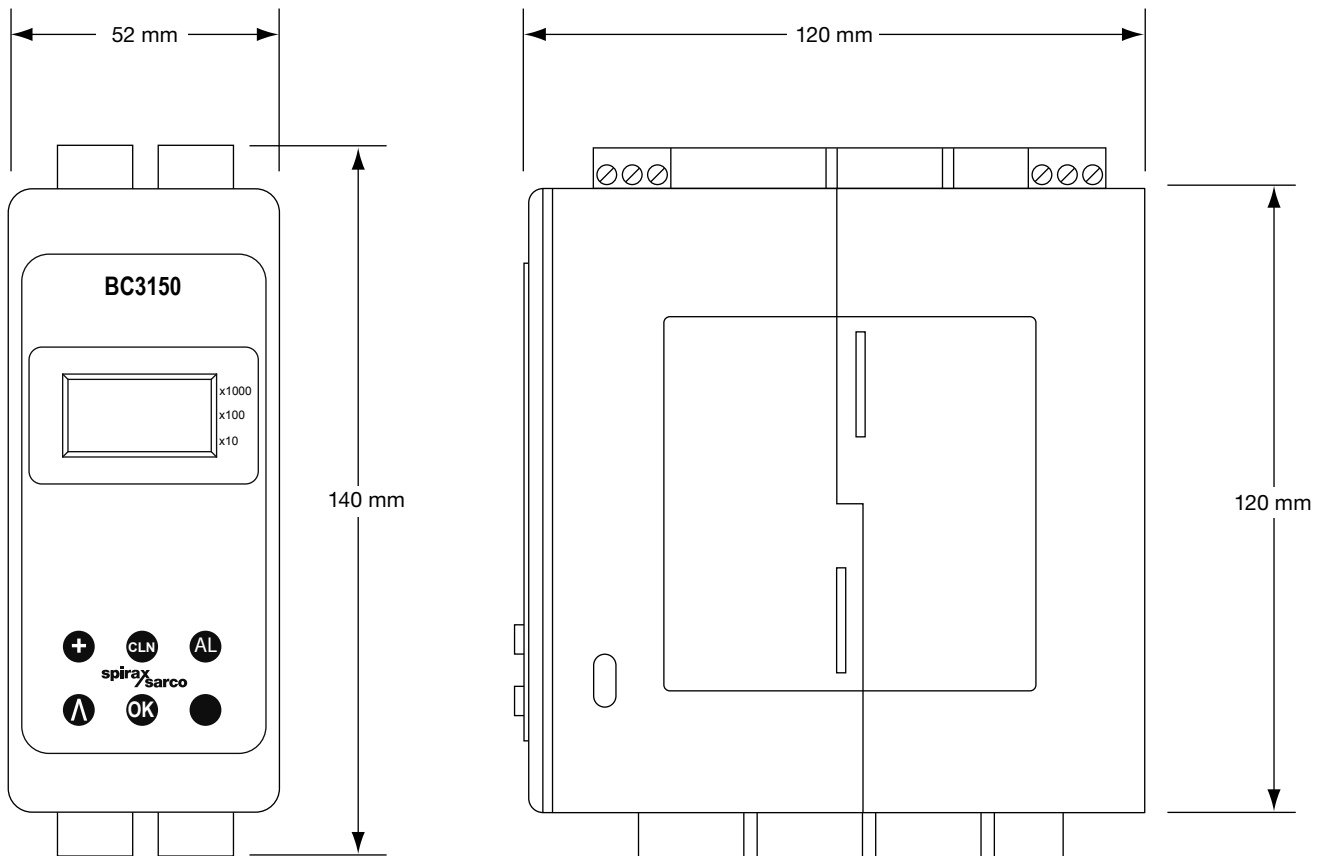

How to specify

Blowdown controller with LCD display and five-button keypad, and infrared communications.

How to order

Example: 1 off Spirax Sarco BC3150 blowdown controller.