



Cert. No. LRQ 0963008

ISO 9001

spirax sarco

TI-P357-10
CH Issue 6

PN5000 Series Spring Extend Pneumatic Actuators (for QL Valves)

Description

A range of compact linear actuators having 6 diaphragm sizes for matching the requirements of different valves at various differential pressures. Each actuator is fitted with mechanical stroke indicators and incorporates a rolling diaphragm to give linearity over the full operating stroke. For precise valve positioning on modulating applications and when using higher pressure spring range actuators a positioner must be used. The actuators are designed for easy conversion to spring retract spindle operation (and vice versa) in the field using the same components and without the need of special tools.

These actuators are designed to operate with 3-port QL43M, QL43D, QL73M and QL73D series valves as detailed below.

Valve type **Actuator type**

QL series DN15 to DN50 (QL43D series starts at DN25) 20 mm travel

QL series DN65 to DN100 30 mm travel

Available types

PN5100 series, single spring, yoke mounted.

PN5200, 5300, 5400, 5500, 5600 series, multi-spring, pillar mounted.

Technical data

Temperature range -20 to +110°C

Maximum operating pressure PN5100, PN5200, PN5300 and PN5400 6 bar

PN5500 and PN5600 2.5 bar

Spring ranges

Actuator type	Spring range	Travel
PN5123	2 to 4 bar	
PN5126	1 to 2 bar	20 mm
PN5120	0.2 (0.4) to 1.0 (1.2) bar	
PN5220	0.2 (0.4) to 1.0 (1.2) bar	
PN5226	1 to 2 bar	20 mm
PN5223	2 to 4 bar	
PN5320	0.2 (0.4) to 1.0 (1.2) bar	
PN5326	1 to 2 bar	20 mm
PN5323	2 to 4 bar	
PN5330	0.4 to 1.2 bar	
PN5336	1 to 2 bar	30 mm
PN5333	2 to 4 bar	
PN5420	0.2 (0.4) to 1.0 (1.2) bar	
PN5426	1 to 2 bar	20 mm
PN5423	2 to 4 bar	
PN5430	0.4 to 1.2 bar	
PN5436	1 to 2 bar	30 mm
PN5433	2 to 4 bar	
PN5520	0.2 (0.4) to 1.0 (1.2) bar	
PN5524	0.8 to 1.5 bar	20 mm
PN5530	0.2 (0.4) to 1.0 (1.2) bar	
PN5534	0.8 to 1.5 bar	30 mm
PN5620	0.2 (0.4) to 1.0 (1.2) bar	
PN5624	0.8 to 1.5 bar	20 mm
PN5630	0.2 (0.4) to 1.0 (1.2) bar	
PN5634	0.8 to 1.5 bar	30 mm

Air supply connection

Actuator type **Connection**

PN5100 and PN5200 series 1/8" NPT

PN5300, PN5400, PN5500 and PN5600 series 1/4" NPT

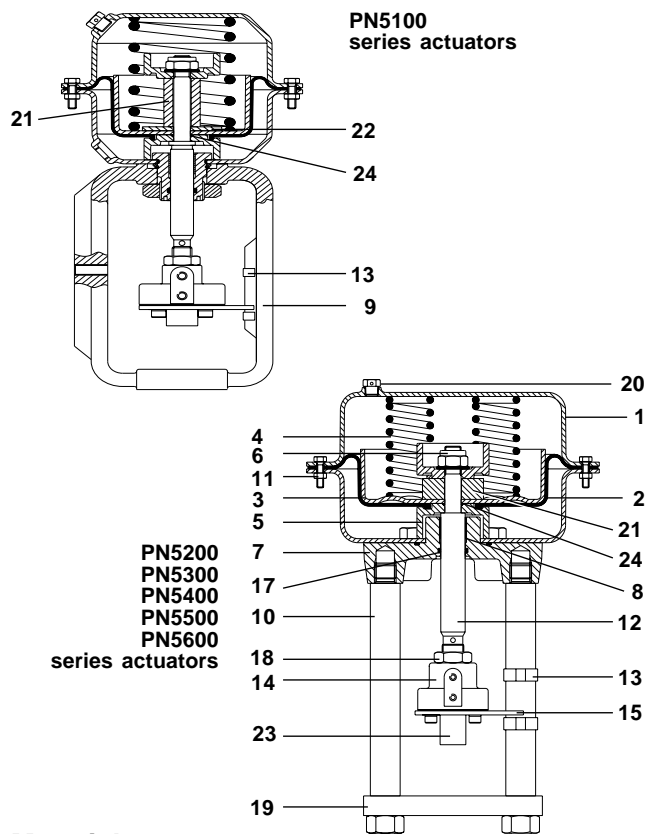

Materials

No	Part	Material
1	Diaphragm housing	Pressed steel
2	Rolling diaphragm	Fabric reinforced nitrile rubber
3	Piston	Pressed steel
4	Spring	Spring steel
5	Diaphragm clamp casting	Stainless steel
6	Nyloc nut	Steel
7	Baseplate	SG iron
8	DU bearing	PTFE/Steel composite
9	Yoke (PN5100 series only)	Aluminium
10	Pillars	Steel
11	Housing securing nuts & bolts	Steel
12	Spindle	Stainless steel
13	Travel indicators	Spring steel
14	Connector	Steel
15	Indicator plate	Steel
17	'O' ring	Rubber
18	Lock-nut	Steel
19	Mounting flange	Stainless steel
20	Cap (with vent hole)	Nickle plated brass
21	Spacer	Steel
22	Spring location washer (PN5100 series)	Steel
23	Adaptor	Steel
24	'O' ring	Rubber

Local regulations may restrict the use of this product to below the conditions quoted.

In the interests of development and improvement of the product, we reserve the right to change the specification.

© Copyright 2000

Differential pressures for QL valves and PN5000 series actuators

Note: Differential pressures shown apply to valves having chevron or bellow sealed stems with either metal-to-metal or PTFE soft seat. For valves having graphite packed stem seals, contact Spirax Sarco.

QL valves

Valve size	DN15	DN20	DN25	DN32	DN40	DN50	DN65	DN80	DN100	
Travel	20 mm						30 mm			
Kvs	0.4 to 4	6	10	17	25	35	62	100	130	

PN5000 series actuators (spring extend spindle)

Actuator	Spring range	Minimum air pressure bar g †	Positioner required	Maximum differential pressure (bar)									
				40.0	38.0	23.0	-	-	-	-	-	-	
PN5123	2.0 to 4.0	6.0	Yes	40.0	38.0	23.0	-	-	-	-	-	-	-
PN5126	1.0 to 2.0	3.0	Yes	34.1	16.1	8.7	3.1	1.1	-	-	-	-	-
PN5120	0.2 to 1.0	1.2	Optional	3.0	3.0	-	-	-	-	-	-	-	-
	0.4 to 1.2*	1.6	Optional	7.0	7.0	3.4	-	-	-	-	-	-	-
PN5220	0.2 to 1.0	1.2	Optional	7.0	7.0	4.0	2.3	1.0	-	-	-	-	-
	0.4 to 1.2*	1.6	Optional	17.0	17.0	10.0	6.0	3.5	1.7	-	-	-	-
PN5226	1.0 to 2.0	3.0	Yes	40.0	40.0	23.2	13.4	8.0	4.4	-	-	-	-
PN5223	2.0 to 4.0	6.0	Yes	40.0	40.0	40.0	34.0	22.0	13.0	-	-	-	-
PN5320	0.2 to 1.0	1.2	Optional	11.0	11.0	7.0	4.0	2.0	1.0	-	-	-	-
	0.4 to 1.2*	1.6	Optional	26.0	26.0	15.0	9.5	5.5	3.0	-	-	-	-
PN5326	1.0 to 2.0	3.0	Yes	40.0	40.0	37.0	21.9	13.6	7.9	-	-	-	-
PN5323	2.0 to 4.0	6.0	Yes	40.0	40.0	40.0	40.0	34.0	20.0	-	-	-	-
PN5330	0.4 to 1.2	1.6	Optional	-	-	-	-	-	-	0.7	-	-	-
PN5336	1.0 to 2.0	3.0	Yes	-	-	-	-	-	-	4.1	2.6	1.1	-
PN5333	2.0 to 4.0	6.0	Yes	-	-	-	-	-	-	11.0	7.0	4.0	-
PN5420	0.2 to 1.0	1.2	Optional	19.0	19.0	10.0	6.5	3.6	2.0	-	-	-	-
	0.4 to 1.2*	1.6	Optional	40.0	40.0	23.0	14.0	9.0	5.0	-	-	-	-
PN5426	1.0 to 2.0	3.0	Yes	40.0	40.0	40.0	35.3	22.4	13.3	-	-	-	-
PN5423	2.0 to 4.0	6.0	Yes	40.0	40.0	40.0	40.0	40.0	30.0	-	-	-	-
PN5430	0.4 to 1.2	1.6	Optional	-	-	-	-	-	-	2.3	1.3	0.5	-
PN5436	1.0 to 2.0	3.0	Yes	-	-	-	-	-	-	7.5	5.0	2.5	-
PN5433	2.0 to 4.0	6.0	Yes	-	-	-	-	-	-	18.0	12.0	7.0	-
PN5520	0.2 to 1.0	1.2	Optional	40.0	40.0	21.0	14.0	8.5	5.0	-	-	-	-
	0.4 to 1.2*	1.6	Optional	-	-	40.0	29.0	18.0	11.0	-	-	-	-
PN5524	0.8 to 1.5	2.3	Yes	40.0	40.0	40.0	40.0	40.0	23.0	-	-	-	-
PN5530	0.2 to 1.0	1.2	Optional	-	-	-	-	-	-	2.4	1.3	0.5	-
	0.4 to 1.2*	1.6	Optional	-	-	-	-	-	-	6.0	4.0	2.0	-
PN5534	0.8 to 1.5	2.3	Yes	-	-	-	-	-	-	14.0	9.0	5.0	-
PN5620	0.2 to 1.0	1.2	Optional	40.0	40.0	33.0	20.0	13.0	7.6	-	-	-	-
	0.4 to 1.2*	1.6	Optional	-	-	40.0	40.0	26.0	16.0	-	-	-	-
PN5624	0.8 to 1.5	2.3	Yes	40.0	40.0	40.0	40.0	40.0	33.0	-	-	-	-
PN5630	0.2 to 1.0	1.2	Optional	-	-	-	-	-	-	3.8	2.3	1.0	-
	0.4 to 1.2*	1.6	Optional	-	-	-	-	-	-	9.0	6.0	3.0	-
PN5634	0.8 to 1.5	2.3	Yes	-	-	-	-	-	-	20.0	13.0	7.0	-

† When using a positioner, refer to the positioner literature for the minimum and maximum air pressure.

* Spring setting

If specified, 0.2 to 1.0 bar spring range can be 'Set at' 0.4 to 1.2 bar to provide higher maximum differential pressures. This higher range is 'Set' when the valve and actuator are assembled together prior to despatch or by following the procedure given in the Installation and Maintenance Instructions provided with the product.

Reduced capacity (Kvs) valves

For valves having reduced capacity K_{Vs} trims differential pressures should be selected from the above chart using the actual K_{Vs} value column and not the valve size column.

Note: For product compatibility with DN65, DN80 and DN100 valves, 30 mm travel actuators must be selected for all trim options. For valves having 20 mm travel reduced K_{Vs} trims it is therefore recommended to use a positioner to obtain the desired travel.

Installation

Actuators should be mounted with the stem in a vertical position. Installation and Maintenance Instructions are supplied with the product.

Spare parts

Information regarding spare parts available is given on TI-P357-01.

How to order

Example: 1 off PN5220 pneumatic actuator.

Note: Specify 'Set at 0.4 to 1.2 bar range' if required.

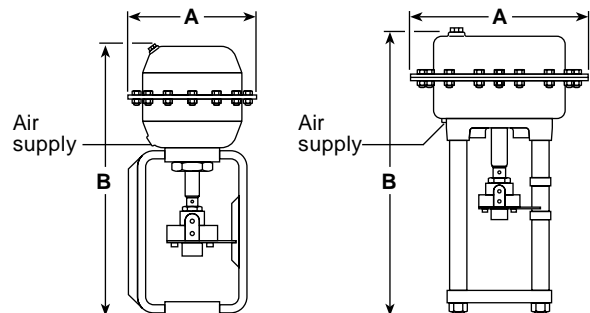

Dimensions/weights (approximate) in mm and kg

Actuator	A	B	Weight
PN5100 series	147	288	3.5
PN5200 series	217	324	7.8
PN5300 series	251	330	10.9
PN5400 series	305	367	18.8
PN5500 series	405	400	26.0
PN5600 series	465	400	36.0