

Gilflo ILVA Flowmeter

Description

The Gilflo ILVA flowmeter operates on the spring loaded variable area principle and produces a differential pressure related to the rate of flow. It can be used with most industrial fluids, gases and both saturated and superheated steam. A general description of the ILVA flowmetering system and its associated equipment is given in a separate TI sheet.

Sizes and pipe connections

DN50, DN80, DN100, DN150, DN200. For DN250 and DN300 sizes see separate literature.

Suitable for fitting between the following flanges:

EN 1092 PN16, PN25 and PN40.

BS 10 Table H.

ASME (ANSI) B 16.5 Class 150, 300 and 600.

JIS 20.

KS 20.

The Gilflo ILVA flowmeter should be installed in pipework manufactured to BS 1600 or ASME (ANSI) B 36.10 Schedule 40. For different pipe standards/schedules downstream spool pieces with equivalent internal diameter as in BS 1600 or ASME (ANSI) B 36.10 Schedule 40 should be used. If this is not possible, please contact Spirax Sarco Limited.

Materials

Part	Material
Body	Cast stainless steel S.316 (CF8M / 1.4408)
Internals	431 S29 / S303 / S304 / S316
Spring	Inconel X750

Pressure/temperature limits

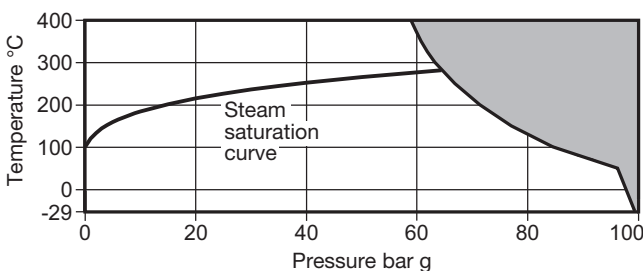

 The product **must not** be used in this region.

Body design conditions	ASME (ANSI) 600
PMA Maximum allowable pressure	102 bar g @ 20°C
TMA Maximum allowable temperature	400°C @ 40 bar g
Minimum allowable temperature	-50°C
PMO Maximum operating pressure is dependant on the flange specification	
Minimum operating pressure	0.6 bar g
TMO Maximum operating temperature	400°C @ 40 bar g
Minimum operating temperature	-29°C
Note: For lower operating temperatures consult Spirax Sarco	
Maximum viscosity	30 centipoise
ΔPMX Maximum differential pressure	498 m bar
Designed for a maximum cold hydraulic test pressure of 155 bar g	

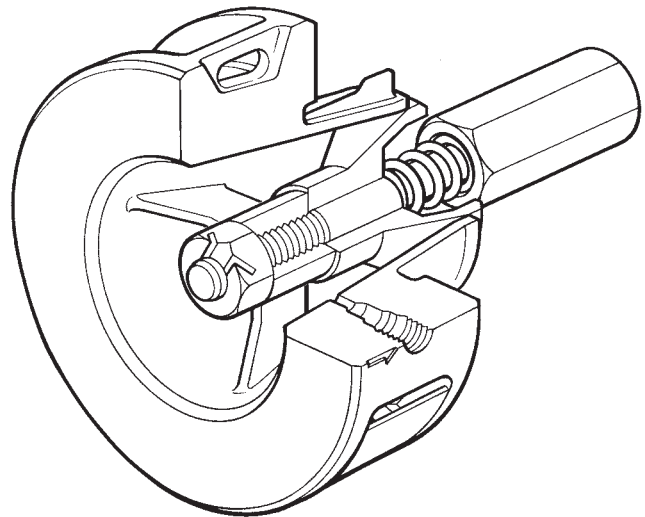

Performance

The Gilflo ILVA is designed to be used in conjunction with linearising electronics such as the M800 flow computer or M750 display unit. Alternatively the output signal linearisation can be performed on an EMS / BEMS or equivalent.

Accuracy when used with M800 or M750:

±1% of measured value from 5% to 100% of maximum rated flow.

±0.1% FSD from 1% to 5% of maximum rated flow.

Repeatability better than 0.25%

Turndown: up to 100:1

Caution: Scanner 2000 steam mass flow transmitters are uniquely configured at the factory to work with a single, specific Gilflo ILVA flowmeter. For correct operation the configured Scanner 2000 transmitter must always be installed with its allocated flowmeter. Labels on the packaging give the serial numbers of the matched products.

Pressure drop

The maximum pressure drop across the Gilflo ILVA pipeline unit is 498 m bar (200 ins water gauge) at maximum rated flow.

Flow capacity

To determine the capacity of the Gilflo ILVA for different fluids, it is necessary to calculate the equivalent water flowrate Q_E (in l/min) as described in Step 1, under the section 'sizing the Gilflo ILVA' then selecting the appropriate size of flowmeter from the Table under Step 2 overleaf.

How to order

Example: 1 off Spirax Sarco DN150 Gilflo ILVA flowmeter for installation between flanges to EN 1092 PN40. Body material 316 stainless steel. Flow medium saturated steam at 10 bar g, maximum flow 8 000 kg / h.

Dimensions / weights (approximate) in mm and kg

Size	A	B	C	D	E	Weight
DN50	35	63	140	103	17.5	2.0
DN80	45	78	150	138	22.5	3.9
DN100	60	103	205	162	30.0	8.3
DN150	75	134	300	218	37.5	14.2
DN200	85	161	360	273	42.5	23.6

Note:- Pressure tappings are threaded 1/4" NPT

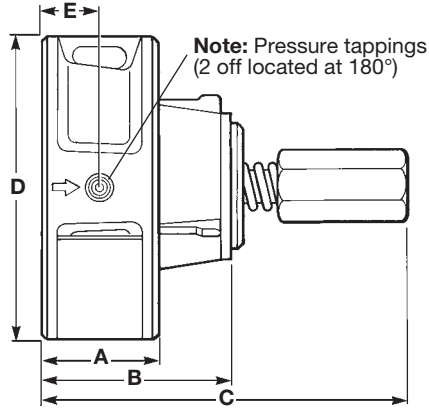

Safety information, installation and maintenance

For full details see the Installation and Maintenance Instructions supplied with the product.

Installation note:

The following main points are given here for guidance:

- The Gilflo ILVA should be mounted with a minimum of 6 straight pipe diameters upstream and 3 downstream. No valves, fittings or cross sectional changes are permitted within these pipe lengths. Where an increase in nominal pipe diameter is required upstream of the flowmeter, the length of straight pipe should be increased to 12 diameters. Similarly, where a Gilflo ILVA is installed downstream of two 90 degree bends in two planes, a pressure reducing valve or a partially open valve, 12 upstream pipe diameters should be allowed.
- It is important that the internal upstream and downstream diameters of pipe are smooth. Ideally seamless pipes should be used. It is recommended that slip-on flanges be used to avoid any intrusive weld beads on the internal diameter of the pipe.
- Care should be taken to install the Gilflo ILVA concentrically in the line. If this is not done, flow measurement errors may occur.
- The Gilflo ILVA should be mounted horizontally. For vertical installations, consult Spirax Sarco.
- For steam applications, good basic steam engineering practices should be followed:
 - Correct line drainage through adequate trapping.
 - Good alignment and support of associated pipework.
 - Line size changes achieved by the use of eccentric reducers.

Maintenance note:

There are no user serviceable parts in the Gilflo ILVA. A visual check together with confirmation that the orifice/cone reference dimension is within tolerance is possible.

Sizing the Gilflo ILVA for saturated steam - kg/h

Minimum and maximum flowrates in kg/h at different pressures (bar g)

Note: Maximum steam flowrates are calculated at maximum differential pressure.

Size		Steam pressure bar g										
		1	3	5	7	10	12	15	20	25	30	40
DN50	Maximum	307	427	517	594	693	752	832	952	1060	1160	1341
	Minimum	3	4	5	6	7	8	8	10	11	12	13
DN80	Maximum	1206	1675	2032	2332	2721	2951	3268	3740	4163	4554	5265
	Minimum	12	17	20	23	27	30	33	37	42	46	53
DN100	Maximum	2475	3435	4167	4784	5581	6054	6703	7671	8540	9341	10800
	Minimum	25	34	42	48	56	61	67	77	85	93	108
DN150	Maximum	5981	8301	10071	11562	13487	14631	16119	18538	20639	22573	26101
	Minimum	60	83	101	116	135	146	162	185	206	226	261
DN200	Maximum	11756	16317	19796	22726	26509	28757	31840	36437	40566	44368	51301
	Minimum	118	163	198	227	265	288	318	364	406	444	513

How to order example: 1 off Spirax Sarco DN50 Gilflo ILVA flowmeter suitable for fitting between EN 1092 PN40 connections.

Sizing the Gilflo ILVA flowmeter

In order to determine the flow capacity of a Gilflo ILVA pipeline unit, it is necessary to calculate the equivalent water flowrate (Q_E) based on the anticipated actual flow (see Step 1).

The Table below is used to select the appropriate unit (steam only).

Step 1. Determine equivalent water flowrate (Q_E) in l/min:-

	Mass flow units	Volumetric units
Liquids	$Q_E = \frac{q_m}{\sqrt{SG}}$	$Q_E = Q_L \sqrt{SG}$
Gases and steam actual flow conditions	$Q_E = q_M \sqrt{\frac{1000}{D_F}}$	$Q_E = Q_F \sqrt{\frac{D_F}{1000}}$
Gases standard conditions	$Q_E = \frac{q_M}{\sqrt{\frac{D_S}{1000} \times \frac{P_F}{P_S} \times \frac{T_S}{T_F}}}$	$Q_E = Q_S \sqrt{\frac{D_S}{1000} \times \frac{P_S}{P_F} \times \frac{T_F}{T_S}}$

Where:

Q_E = Equivalent water flowrate (litres / min)

q_m = Mass flowrate (kg / min)

Q_L = Maximum liquid flowrate (litres / min)

Q_s = Maximum gas flowrate at standard conditions (litres / min)

Q_F = Maximum gas flowrate at actual flow conditions (litres / min)

SG = Specific gravity

D_s = Density of gas at standard conditions (kg / m³)

D_f = Density of gas at actual flow conditions (kg / m³)

P_s = Standard pressure: 1.013 bar a, 1.033 kg/cm² a, 14.70 psi a

P_f = Actual flow pressure in same absolute units as P_s

T_s = Standard temperature (K) = °C + 273

T_f = Actual flow temperature (K) = °C + 273

Step 2. Using the value of Q_E as determined in Step 1, select the correct size of the Gilflo ILVA flowmeter using the Table below. In practice, it will often be the line size that determines the choice of the flowmeter.

Flowmeter type	Q_E litres / min		Maximum DP	
	Maximum	Minimum	Wg	m bar
DN50	149	1	200	498
DN80	585	6	200	498
DN100	1200	12	200	498
DN150	2900	29	200	498
DN200	5700	57	200	498

Example: Determine which Gilflo pipeline unit is required to measure the flow of compressed air when:

1: Estimated maximum rate of flow = 500 s m³/h at 7 bar g and 20°C
 Note: Standard conditions = 1.013 bar a, 0°C giving a standard density of 1.29 kg / m³

$$2: \text{ Calculate } Q_E \text{ from: } Q_E = Q_s \sqrt{\frac{D_s}{1000} \times \frac{P_s}{P_f} \times \frac{T_f}{T_s}}$$

$$Q_E = (500 \times 16.667) \times \sqrt{\frac{1.29}{1000} \times \frac{1.013}{8.013} \times \frac{293}{273}}$$

$$Q_E = 110 \text{ litres / min}$$

So a DN50 ILVA is recommended.

Note: 1 m³ / h = 16.667 litres / min