



Cert. No. LRQ 0963008

ISO 9001

# spirax sarco

**TI-P316-01**  
 CH Issue 14

## SV615 Safety Valve

### Description

The SV615 full lift, full nozzle safety valve is suitable for steam, air, inert industrial gas and non-hazardous liquid service.

### Applications

The SV615 is suitable for the protection of steam or hot water boilers, generators, vessels, receivers and air compressors, autoclaves, downstream of pressure reducing valves and for general pressure relief applications.

### Available types

Valves are available in sizes ranging from DN15 to DN50 and have a bronze body with female screwed connections and a stainless steel nozzle. There is also the option of a sanitary clamp inlet connection on the smaller sizes. All valves have a closed bonnet with either a lifting lever or closed cap (gas tight cap option). An optional soft seal is available in Nitrile, EPDM or Viton. Where frequent washdown occurs or aesthetic appearance is a consideration, this product can also be supplied with an electroless nickel plated (ELNP) finish to the body, lever housing (or sealed cap) and lever. A mechanically fastened stainless steel name-plate can also be provided - For full details contact Spirax Sarco.

### Standards and approvals

The SV615 complies with the requirements of EN ISO 4126:2004 and carries the **CE** mark indicating full compliance with the requirements of the European Pressure Equipment Directive 97/23/EC. Approval Authority and Notified Body is SAFed TAS. Seat tightness complies with ANSI/API STD 527- Revision 2002.

### Certification

A manufacturers' Typical Test Report is provided as standard for each valve which will include valve set and hydraulic test pressure. Also available on request is material certification in accordance with EN 10204 3.1.

### Pressure/temperature limits

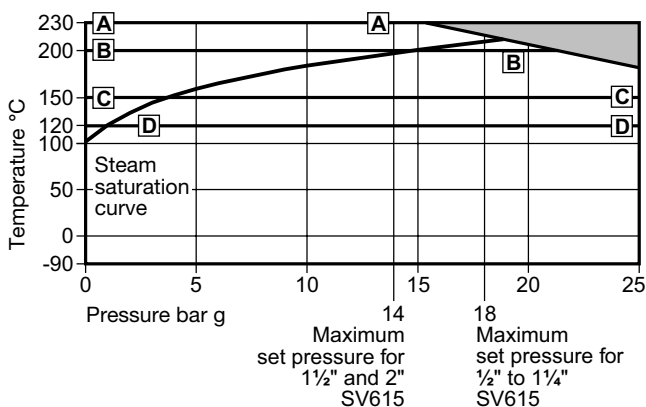

The product **must not** be used in this region.

- A - A** Maximum operating temperature with metal seat.
- B - B** Maximum operating temperature with Viton seat.
- C - C** Maximum operating temperature with EPDM seat.
- D - D** Maximum operating temperature with Nitrile seat.

### Sizes and end connections

DN15, DN20, DN25, DN32, DN40 and DN50.

#### Inlet connections

Screwed BSP (BS 21 parallel) or NPT female connections. Sanitary clamp compatible (DN15, DN20 and DN25 sizes only) BS 4825 / ISO 2852 / DIN 32676 - Safety valves with these connections have a surface finish of 0.8 µm on primary wetted parts.

#### Outlet connections

Screwed BSP (BS 21 parallel) or NPT female connection.

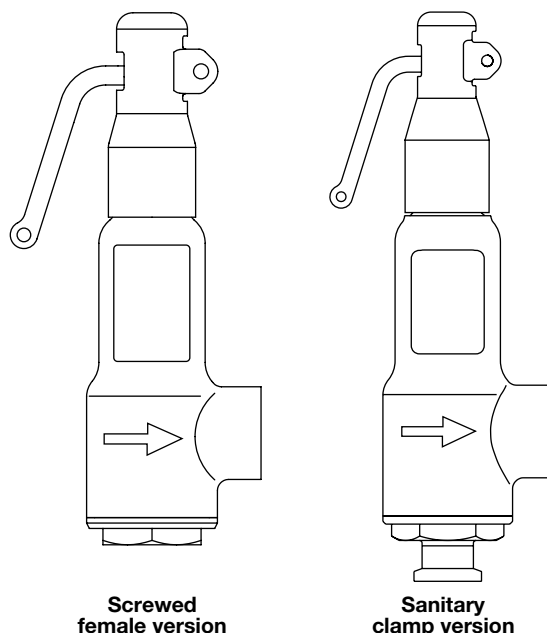

Body design conditions		PN25	
Set pressure range	Maximum	1/2" to 1 1/4"	18 bar g
	Minimum	1 1/2" and 2"	14 bar g
Temperature	Metal seat	Minimum	-90°C
		Maximum	+230°C
	Nitrile seat *	Minimum	-30°C
		Maximum	+120°C
	EPDM seat *	Minimum	-50°C
		Maximum	+150°C
Viton seat *	Minimum	-20°C	
	Maximum	+200°C	
Overpressure	Steam	5%	
	Gas	10%	
	Liquid	10 to 25%	
Performance data	Blowdown limits	Steam, gas	10%
		Liquids	2.5 to 20%
Derated coefficient of discharge values	Steam, gas	0.71	
	Liquid	0.52	

Maximum permitted backpressure 10% of set pressure  
 Tested at a maximum inlet cold hydraulic test pressure of 37.5 bar g

\*Note: Soft seal inserts are not suitable for steam applications.

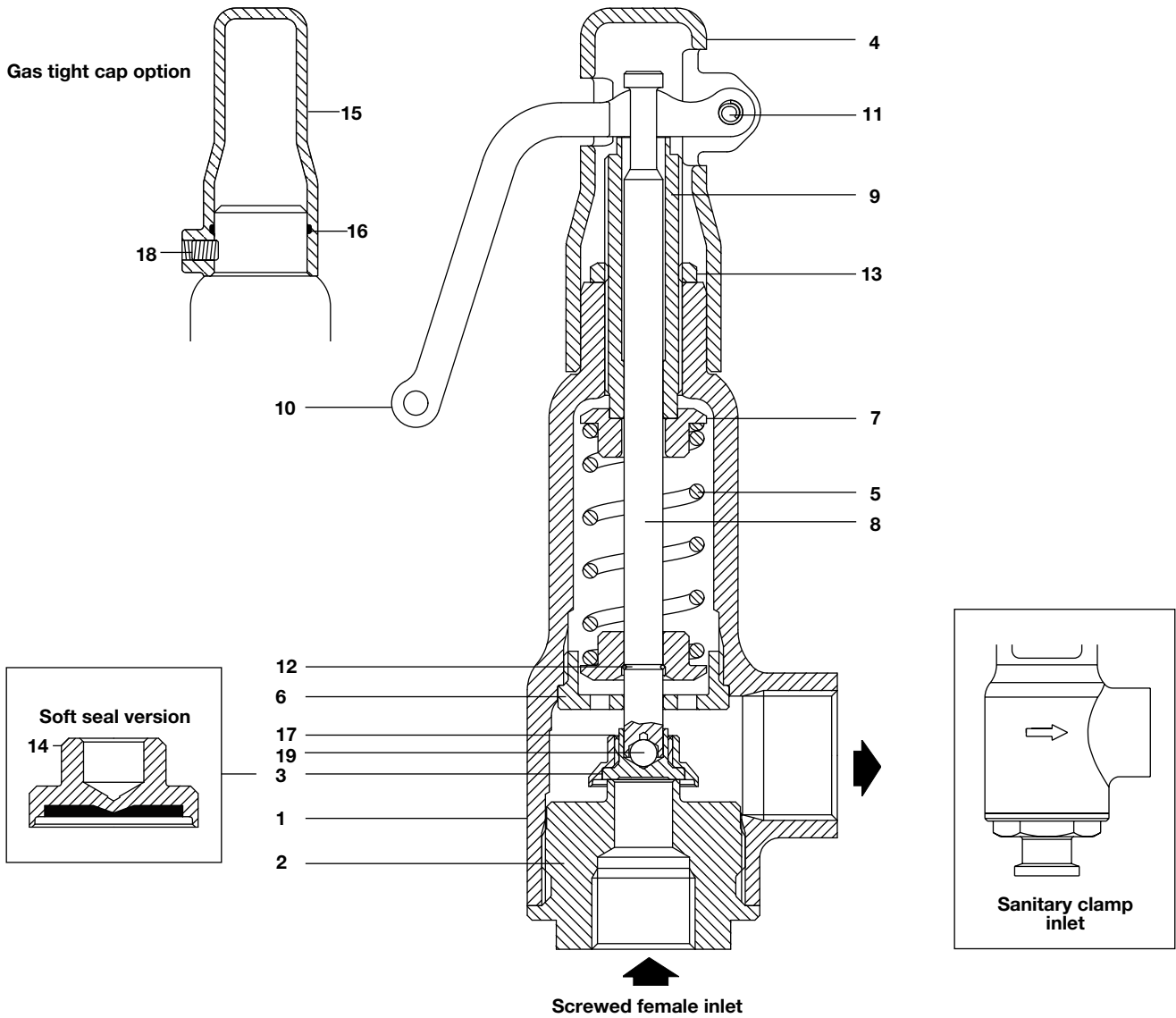

**Materials**

No.	Part	Material	
1	Body	Bronze	BS EN 1982 CC491KM
2	Nozzle	DN15 and DN20	Stainless steel BS 970 431 S29
		DN25 to DN50	Stainless steel BS 3146 Pt2 Gr. ANC2
		Sanitary connections	Stainless steel ASTM A276 316L
3	Disc	Stainless steel	ASTM A276 316L
4	Lever housing	Bronze	BS EN 1982 CC491KM
5	Spring	Chrome-vanadium alloy steel	BS 2803 735 A50 HS
6	Stem guide	Brass	BS 2872 CZ 121
7	Spring end plate	Brass	BS 2872 CZ 121
8	Stem	Stainless steel	BS 970 431 S29
9	Adjustment screw	Brass	BS 2874 CZ 121
10	Lever	SG iron	Zinc plated
11	Pivot pin	Stainless steel	AISI 304
12	Circlip	Stainless steel	BS 2056 316 S42
13	Adjuster lock-nut	Brass	BS 2872 CZ 121
14	Soft seal disc	Stainless steel / Nitrile insert	ASTM A276 316
		Stainless steel / EPDM insert	ASTM A276 316
		Stainless steel / Viton insert	ASTM A276 316
15	Sealed cap	Bronze	BS EN 1982 CC491KM
16	Cap seal	Nitrile	
17	Skirt	Brass	BS 2874 CZ 121
18	Grub screw	Steel	
19	Ball	Stainless steel	

**Table 1 - SV615 flow capacity for saturated steam in kilogrammes per hour (kg/h)**

(calculated in accordance with EN ISO 4126:2004 at 5% overpressure)

Derated coefficient of discharge (Kdr) = 0.71

Valve size DN in/out	15/20	20/32	25/40	32/50	40/65	50/80
Flow area (mm <sup>2</sup> )	113	314	452	661	1075	1662

Set pressure (bar g)	Flow capacity for dry saturated steam kg/h					
0.5	71	198	285	417	678	1049
1.0	95	263	379	554	901	1393
1.5	118	328	472	690	1122	1734
2.0	141	392	564	824	1341	2073
2.5	164	455	655	959	1559	2410
3.0	187	519	747	1092	1776	2746
3.5	209	582	838	1225	1993	3081
4.0	232	645	929	1358	2008	3414
4.5	255	708	1019	1490	2424	3747
5.0	277	771	1109	1622	2638	4079
5.5	300	833	1199	1754	2853	4410
6.0	322	896	1289	1886	3067	4741
6.5	345	958	1379	2017	3280	5071
7.0	367	1020	1469	2148	3494	5401
7.5	390	1083	1559	2279	3707	5731
8.0	412	1145	1648	2410	3920	6060
8.5	434	1207	1737	2541	4132	6389
9.0	457	1269	1827	2672	4345	6717
9.5	479	1331	1916	2802	4557	7046
10.0	501	1393	2005	2933	4769	7374
11.0	546	1517	2184	3194	5194	8030
12.0	591	1641	2362	3454	5618	8685
13.0	635	1765	2540	3715	6042	9340
14.0	680	1888	2718	3975	-	-
15.0	724	2012	2897	4236	-	-
16.0	769	2136	3075	4496	-	-
17.0	813	2260	3253	4757	-	-
18.0	858	2384	3431	5018	-	-

**Table 2 - SV615 flow capacity for air in litres per second (l/s) at 15°C and 1.013 bar a**

(calculated in accordance with EN ISO 4126:2004 at 10% overpressure)

Derated coefficient of discharge (Kdr) = 0.71

Valve size DN in/out	15/20	20/32	25/40	32/50	40/65	50/80
Flow area (mm <sup>2</sup> )	113	314	452	661	1075	1662

Set pressure (bar g)	Flow capacity for air l/s					
0.5	24	67	97	142	230	356
1.0	33	91	131	191	311	481
1.5	41	115	165	241	392	606
2.0	50	138	199	291	473	732
3.0	67	186	267	391	635	982
4.0	84	233	335	490	797	1233
5.0	101	280	403	590	959	1483
6.0	118	328	472	690	1121	1734
7.0	135	375	540	789	1283	1984
8.0	152	422	608	889	1446	2235
9.0	169	470	676	988	1608	2485
10.0	186	517	744	1088	1770	2736
11.0	203	564	812	1188	1932	2986
12.0	220	612	880	1287	2094	3237
13.0	237	659	948	1387	2256	3487
14.0	254	706	1017	1487	2418	3738
16.0	288	801	1153	1686	-	-
18.0	322	896	1289	1885	-	-

**Table 3 - SV615 flow capacity for water in kilogrammes per hour (kg/h) at 20°C**

(calculated in accordance with EN ISO 4126:2004 at 10% overpressure)

Derated coefficient of discharge (Kdr) = 0.52

Valve size DN in/ out	15/20	20/32	25/40	32/50	40/65	50/80
Flow area (mm <sup>2</sup> )	113	314	452	661	1 075	1 662

Set pressure (bar g)	Flow capacity for water kg/h					
0.5	2 216	6 159	8 866	12 965	21 086	32 599
1.0	3 135	8 710	12 538	18 335	29 819	46 102
1.5	3 839	10 668	15 356	22 456	36 521	56 463
2.0	4 433	12 318	17 731	25 930	42 171	65 198
3.0	5 429	15 086	21 717	31 758	51 649	79 851
4.0	6 269	17 420	25 076	36 671	59 639	92 204
5.0	7 009	19 476	28 036	40 999	66 678	103 088
6.0	7 678	21 335	30 712	44 913	73 042	112 927
7.0	8 293	23 045	33 173	48 511	78 895	121 975
8.0	8 866	24 636	35 463	51 861	84 342	130 397
9.0	9 404	26 130	37 614	55 006	89 458	138 307
10.0	9 912	27 544	39 649	57 982	94 297	145 788
11.0	10 396	28 888	41 584	60 812	98 900	152 904
12.0	10 858	30 172	43 433	63 516	103 298	159 703
13.0	11 302	31 405	45 207	66 110	107 515	166 224
14.0	11 728	32 590	46 913	68 605	111 574	172 499
16.0	12 538	34 840	50 152	73 342	-	-
18.0	13 299	36 954	53 194	77 791	-	-

**Table 4 - SV615 flow capacities for hot water in kilowatts (kW) at or above 100°C**

(calculated in accordance with EN ISO 4126:2004)

Derated coefficient of discharge (Kdr) = 0.52

Valve size DN in/ out	15/20	20/32	25/40	32/50	40/65	50/80
Flow area (mm <sup>2</sup> )	113	314	452	661	1 075	1 662

Set pressure (bar g)	Flow capacity for hot water kW					
0.5	29.96	83.26	119.86	175.27	285.06	440.71
1.0	40.60	112.81	162.39	237.47	386.21	597.09
1.5	51.23	142.36	204.92	299.66	487.36	753.47
2.0	61.86	171.96	247.45	361.86	588.51	909.86
3.0	83.13	230.99	332.51	486.24	790.81	1 222.62
4.0	104.39	290.08	417.57	610.63	993.11	1 535.38
5.0	125.66	349.17	502.63	735.02	1 195.42	1 848.15
6.0	146.92	408.26	587.69	859.41	1 397.72	2 160.91
7.0	168.19	467.36	672.75	983.80	1 600.12	2 473.67
8.0	189.45	526.45	757.81	1 108.18	1 802.32	2 786.43
9.0	210.72	585.54	842.88	1 232.57	2 004.62	3 099.20
10.0	231.98	644.63	927.94	1 356.96	2 206.92	3 411.96
11.0	253.25	703.72	1 013.00	1 481.35	2 409.22	3 724.72
12.0	274.51	762.81	1 098.06	1 605.74	2 611.52	4 037.49
13.0	295.78	821.90	1 183.12	1 730.12	2 813.82	4 350.25
14.0	317.04	880.99	1 268.18	1 854.51	3 016.12	4 663.01
16.0	359.58	999.17	1 438.30	2 103.29	-	-
18.0	402.11	1 117.36	1 608.42	2 352.06	-	-

## Sizing and selection

Refer to:- <http://www.spiraxsarco.com/resources/steam-engineering-tutorials/safety-valves/safety-valve-sizing.asp>

## Dimensions/weights (approximate) in mm and kg

	Size	Connection		A	B	C	FlowØ	Weight
		Inlet	Outlet				D	
Screwed BSPF x BSPF or NPTF x NPTF	DN15	1/2"	3/4"	40	40	194	12	1.3
	DN20	3/4"	1 1/4"	55	44	229	20	2.4
	DN25	1"	1 1/2"	60	48	242	24	2.9
	DN32	1 1/4"	2"	70	58	279	29	4.2
	DN40	1 1/2"	2 1/2"	81	67	365	37	8.8
Sanitary clamp	DN50	2"	3"	96	80	420	46	13.0
	DN15	1/2"	3/4"	40	55	209	12	1.4
	DN20	1"	1 1/4"	55	60	245	20	2.6
	DN25	1"	1 1/2"	60	64	258	24	3.1

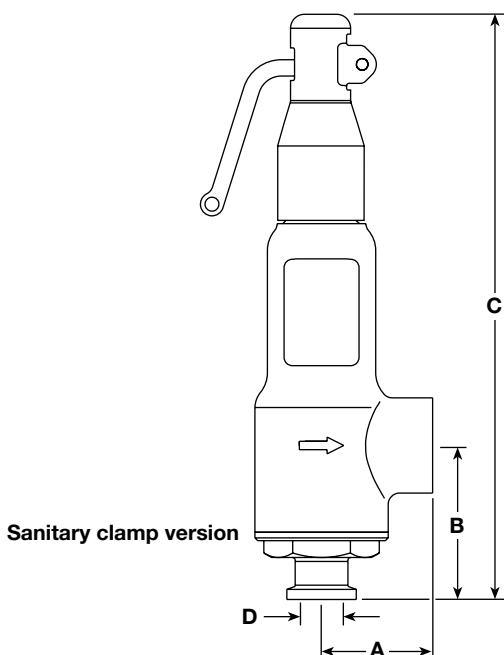
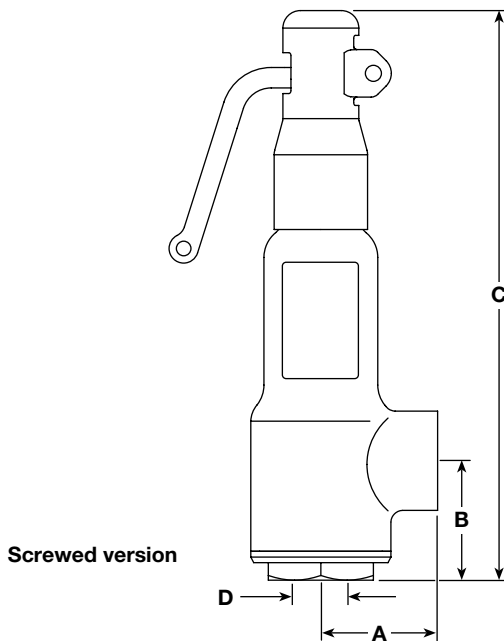

## Safety information, installation and maintenance

For full details see the Installation and Maintenance Instructions (IM-P316-03) supplied with the product.

### Installation note:

The safety valve should always be fitted with the centre line of the spring housing vertically above the valve. Ensure the discharge pipework system is sized correctly.

## SV615 safety valve selection guide:

Model type	SV615	<b>SV615</b>
Configuration	A = Closed bonnet/easing lever B = Closed bonnet/sealed cap	<b>A</b>
Seal material	S = Stainless steel N = Nitrile E = EPDM V = Viton	<b>N</b>
Finish	P = Electroless nickel plated (ELNP) Q = ELNP and stainless steel name-plate	
Size	DN15, DN20, DN25, DN32, DN40 and DN50	<b>DN15</b>
Connections (Inlet x Outlet)	BSPF x BSPF NPTF x NPTF Clamp x BSPF	<b>BSPF x BSPF</b>

## Selection example

<b>SV615</b>	<b>A</b>	<b>N</b>		<b>DN15</b>	<b>BSPF x BSPF</b>
--------------	----------	----------	--	-------------	--------------------

If ELNP finish is required, add 'P'.

## How to order example:

1 off Spirax Sarco SV615AN safety valve having DN15 screwed BSPF x BSPF connections, set at 6 bar g.