



Cert. No. LRQ 0963008

ISO 9001

spirax sarco

SVL488

TI-P315-03
CH Issue 5

Stainless Steel Safety Valve for Clean Service Applications

Description

The SVL488 is a stainless steel, full lift, TÜV approved safety valve suitable for steam, gas and liquid applications.

Applications

The SVL488 is suitable for the overpressure protection of low pressure steam equipment, pipelines and pressure vessels, particularly within the brewing and beverage industries where extremely high standards of hygiene and cleanliness are required to maintain product quality and to minimise contamination of the process media.

Available types

Two main variations of the valve are available:

SVL488-B with a sealed cap for liquid service.

SVL488-C with a packed easing lever for steam (or other services where a lever is specified).

Note: Both designs have a closed bonnet.

Certification

A manufacturers' Typical Test Report is provided as standard for each valve including valve set and hydraulic pressure. Also available on request is material certification in accordance with EN 10204 3.1.

Standards and approvals

Approved by the TÜV to AD Merkblatt A2, TRD 421 and Vd TÜV SV100.

The requirements of the European Pressure Equipment Directive, 97/23/EC have been satisfied and the valve belongs to Category 4, having been designed for use with fluids in Group 1 and 2 (gases and liquids). Always consult Spirax Sarco for fluid compatibility.

Sizes and end connections

Nominal inlet size DN	25	40	50	65	80	100
Nominal outlet size DN	40	65	80	100	125	150
Inlet clamp inch	1½	2	2½	3	4	4½
Outlet clamp inch	2	3	4	4½	5	6

Pipe connections: Valves are available with flanged DIN 2633 PN16 or sanitary clamp ISO 2852 (ISO 2037 pipe standard) connections. Please state connection required when placing an order.

Optional extras

EPDM seat seal (Maximum 4 bar g set pressure on steam).

The standard wetted surface finish is 0.75 µm Ra. Other finishes are available on request - Please contact Spirax Sarco.

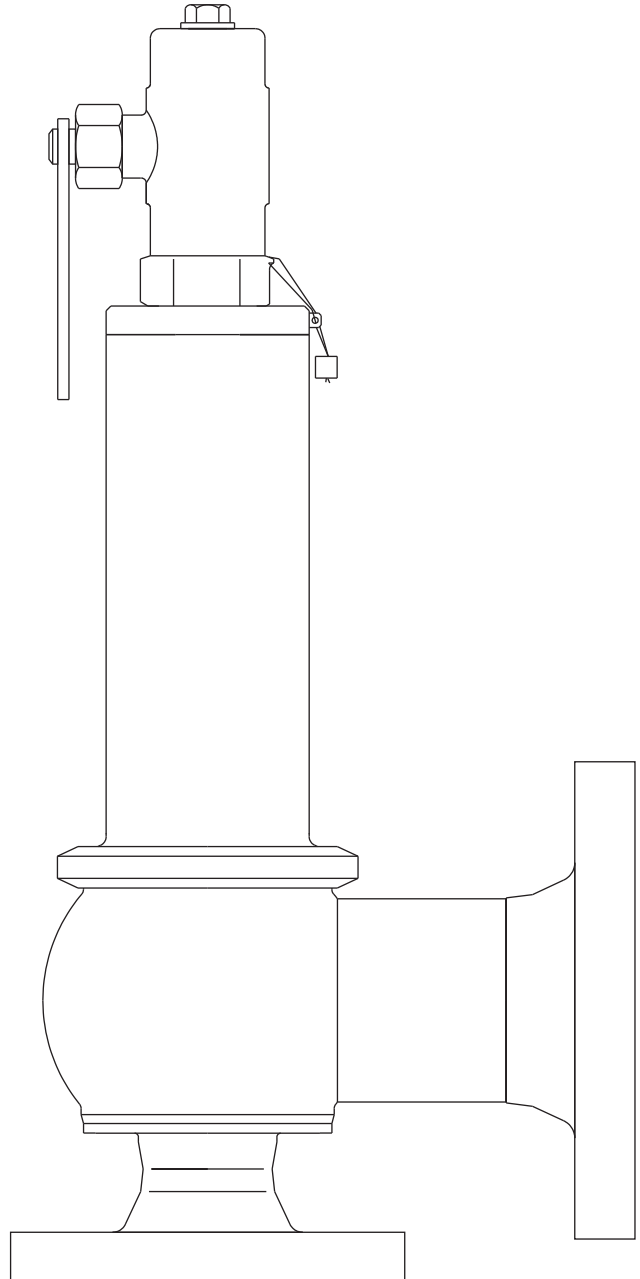

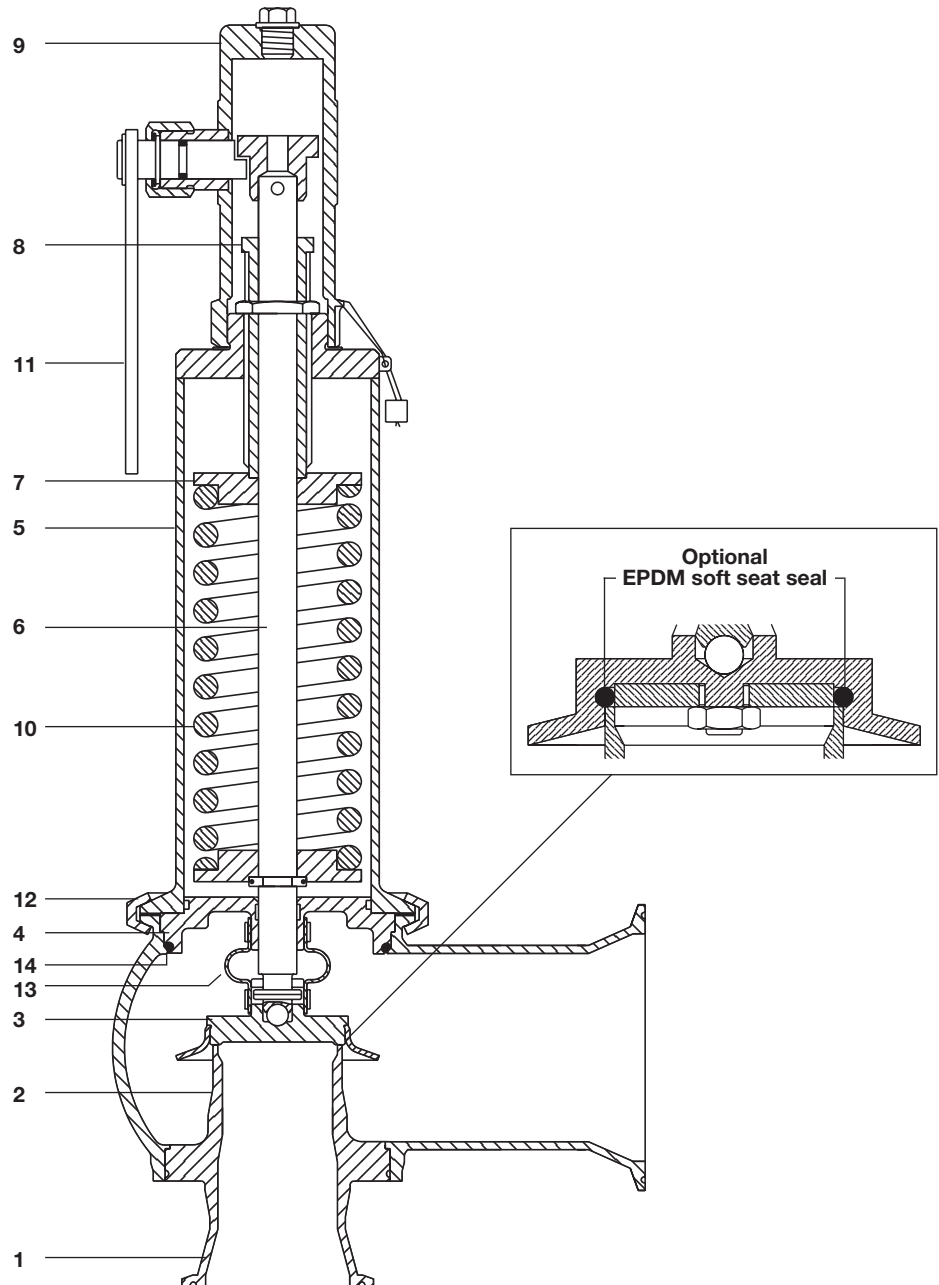

Materials

No.	Part	Material	
1	Body	Stainless steel	1.4404
2	Seat	Stainless steel	1.4404
3	Disc	Stainless steel	1.4404
	Disc 'O' ring (when specified)	EPDM (FDA approved)	
4	Guide/bush	Stainless steel	1.4404/PTFE + 15% Glass
5	Bonnet	Stainless steel	1.4404
6	Stem	Stainless steel	1.4404
7	Spring plates (2)	Stainless steel	1.4404
8	Adjustment screw	Stainless steel	1.4404
	with bush	PTFE + 15% glass	
9	Cap	Stainless steel	1.4404
10	Spring	Stainless steel	1.4310
11	Packed lever	Stainless steel	1.4404
12	Clamp	Stainless steel	1.4401
13	Bellows	EPDM (FDA approved)	
14	Body gasket	Laminated graphite	

Pressure/temperature limits

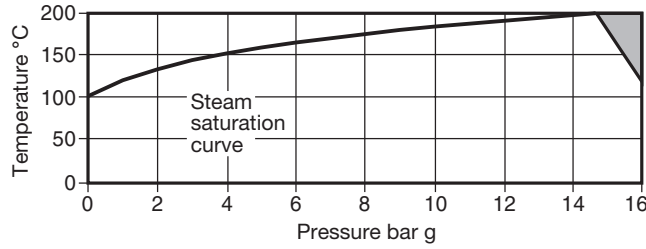

The product **must not** be used in this region.

Body design conditions			PN16
DN25 and DN40	Maximum	16 bar g	
	Minimum	0.1 bar g	
DN50	Maximum	15 bar g	
	Minimum	0.2 bar g	
Set pressure range	Maximum	10.34 bar g	
	Minimum	0.1 bar g	
DN65 and DN80	Maximum	8.2 bar g	
	Minimum	0.1 bar g	
Temperature	With EPDM soft seat	Maximum	150°C
	With stainless steel seat	Maximum	200°C
	All versions	Minimum	-45°C
Performance data	Overpressure	Steam, gas	Maximum 10%
		Liquid	Maximum 10%
	Blowdown limits	Steam, gas	Maximum 10%
		Liquids	Maximum 20%
	Derated coefficient of discharge values α_d	Steam, gas	0.70
		Liquid	0.45
Maximum permitted backpressure			10% of set pressure
Designed for a maximum inlet cold hydraulic test pressure of:			24 bar g

Table 1 - SVL488 flow capacity for dry saturated steam in kilogrammes per hour (kg/h)
(calculated at 10% overpressure. In accordance with EN ISO 4126)

Valve size DN in/out	DN25/40	DN40/65	DN50/80	DN65/100	DN80/125	DN100/150
Flow diameter (mm)	23	37	46	60	74	92
Flow area (mm ²)	416	1075	1662	2827	4301	6648

Set pressure (bar g)	Dry saturated steam, kg/h					
	0.2	151	390	604	1027	1562
0.5	214	554	857	1457	2217	3427
1.0	319	825	1275	2169	3300	5100
2.0	504	1303	2015	3427	5213	8058
3.0	678	1751	2707	4605	7006	10829
4.0	843	2177	3366	5726	8711	13465
5.0	1007	2601	4022	6840	10407	16086
6.0	1170	3023	4674	7951	12096	18697
7.0	1333	3444	5325	9058	13781	21300
8.0	1495	3864	5975	10162	15461	23898
8.2	1591	4112	6357	10814	16452	25429
9.0	1658	4284	6623	11265	17138	
10.0	1820	4702	7270	12366	18813	
10.34	1948	5033	7781	13236	20137	
12.0	2143	5539	8563			
14.0	2574	6653	10285			
15.0	2744	7090	10962			
16.0	2913	7528				

The product **must not** be used in this region

Table 2

SVL488 flow capacity for air or normal cubic meters per hour (Nm³/h) at 0°C and 1013 mbar
(calculated in accordance with AD-MERKBLATT A2 and TRD 421)

Valve size DN in/out	25/40	40/65	50/80	65/100	80/125	100/150
Flow area (mm ²)	416	1075	1662	2827	4301	6648

Set pressure (bar g)	Flow capacity for air Nm ³ /h					
1.0	386	999	1545	2628	3998	6179
2.0	625	1617	2499	4251	6467	9995
3.0	852	2204	3406	5795	8816	13626
4.0	1069	2768	4278	7278	11071	17111
5.0	1287	3331	5149	8761	13326	20597
6.0	1505	3895	6021	10243	15581	24083
7.0	1723	4459	6892	11726	17836	27568
8.0	1941	5023	7763	13208	20091	31054
8.2	1985	5136	7937	13505	20542	31752
9.0	2159	5587	8635	14691	22346	
10.0	2377	6150	9506	16173	24601	
10.34	2451	6334	9793	16658	25343	
12.0	2812	7278	11249			
14.0	3248	8405	12992			
15.0	3466	8957	14735			
16.0	3684	9533				

The product **must not** be used in this region

Table 3 - SVL488 flow capacity for water in kilogrammes per hour (kg/h) at 20°C

(calculated in accordance with AD-MERKBLATT A2 and TRD 421 at 10% overpressure)

Derated coefficient of discharge (Kdr) = 0.52

Valve size DN in/out	25/40	40/65	50/80	65/100	80/125	100/150
Flow area (mm ²)	416	1075	1662	2827	4301	6648

Set pressure (bar g)	Flow capacity for water kg/h					
1.0	9970	25800	39900	67900	103000	160000
2.0	14100	36500	56400	96000	126000	226000
3.0	17300	44700	69100	118000	179000	276000
4.0	19900	51600	79800	136000	206000	319000
5.0	22300	57700	89200	152000	231000	357000
6.0	24400	63200	97700	166000	253000	391000
7.0	26400	68300	106000	180000	273000	422000
8.0	28200	73000	113000	192000	292000	451000
8.2	28500	73900	114000	194000	292000	458000
9.0	29900	77400	120000	204000	310000	
10.0	31500	81600	126000	215000	326000	
10.34	32000	82700	128000	218000	334000	
12.0	34600	89400	138000			
14.0	37300	96600	149000			
15.0	38600	99700	154000			
16.0	39900	103000				

The product **must not** be used in this region

Dimensions / weights (approximate) in mm and kg

Valve size		A		B		C		Weight
Inlet	Outlet	DIN 2633 Flanged PN16	ISO 2852 Sanitary clamp	DIN 2633 Flanged PN16	ISO 2852 Sanitary clamp	SVL488B sealed cap design	SVL488C Packed lever design	
DN25	DN40	134	112	99	75	264	332	9.0
DN40	DN65	170	147	114	92	398	518	20.0
DN50	DN80	170	147	123	99	406	534	21.7
DN65	DN100	170	153	132	109	415	552	26.5
DN80	DN125	195	178	148	124	496	640	47.0
DN100	DN150	198	181	166	149	514	684	56.0

Safety information, installation and maintenance

For full details see the Installation and Maintenance Instructions supplied with the product.

Installation note:

The safety valve should always be fitted with the centre line of the housing vertically above the line.

SVL488 safety valve selection guide

Model type	SVL488	SVL488
Configuration	B = Closed bonnet/sealed cap C = Closed bonnet/packed easing lever	B
Seal material	S = Stainless steel E = EPDM (FDA) 'O' ring and bellows	S
Inlet connection	PN16 = Flanged PN16 T = Sanitary clamp, ISO 2582	PN16
SVL488 - B - S - PN16		

How to order

Example: 1 off Spirax Sarco DN50 SVL488-B-S-PN16 safety valve with a set pressure of 10 bar g. (If the bellows is not required, please add 'without bellows').

