



Cert. No. LRQ 0963008

ISO 9001

spirax sarco

SRV461S and SRV463S

Stainless Steel

Direct Acting Pressure Reducing Valves

TI-P186-01
CH Issue 9

Description

Types SRV461S and SRV463S are direct acting pressure reducing valves with all wetted parts in AISI 316L/1.4404, 1.4408 and 1.4462 stainless steel. For steam, liquid or gas applications. Typical applications include: Clean steam, gas and liquid supplies to centrifuges, freeze dryers, sterilisers, autoclaves, process tanks, humidifiers and culinary equipment.

Sizes and pipe connections

SRV461S	1/2", 3/4", 1", 1 1/4", 1 1/2" and 2" Screwed NPT, BSP
SRV463S	DN15, DN20, DN25, DN32, DN40 and DN50 Flanged ASME (ANSI) 150, EN 1092 PN16

Pressure / temperature limits

SRV461S

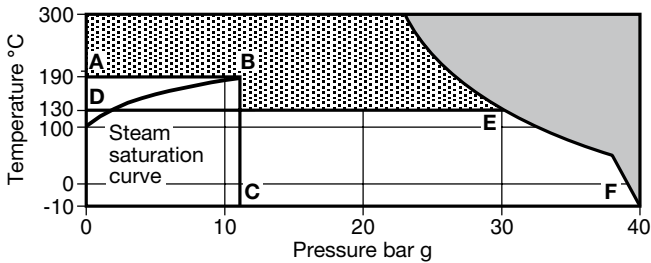

SRV463S

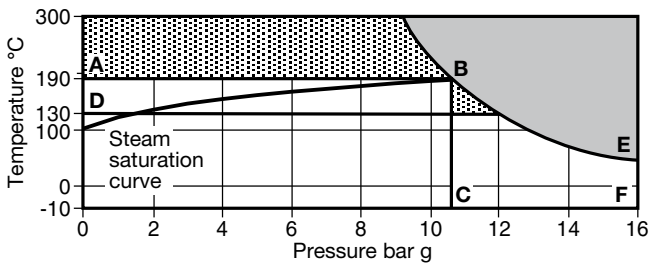

- The product **must not** be used in this region.
- The product should not be used in this region or beyond its operating range as damage to the internals may occur.

- A - B - C** Maximum operating conditions for steam
- D - E - F** Maximum operating conditions for liquids and gases

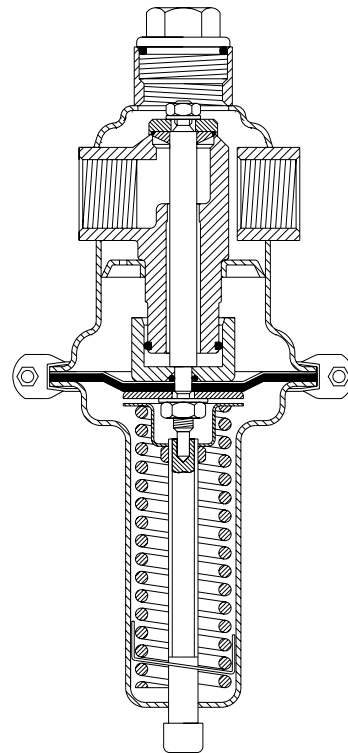

Body design conditions	SRV461S	PN40
	SRV463S	PN16
Maximum design pressure	SRV461S	38 bar g @ 38°C
	SRV463S	15.2 bar g @ 50°C
Maximum design temperature	SRV461S	300°C @ 23.2 bar g
	SRV463S	300°C @ 9 bar g
Minimum design temperature		-10°C
Maximum operating temperature	Steam	190°C @ 10.9 bar g
	Liquid and gases	130°C @ 12 bar g
Minimum operating temperature		-10°C
Note: for lower operating temperatures consult Spirax Sarco		
Maximum differential pressure	see the Permissible reduction ratio table opposite	
Designed for a maximum cold hydraulic test pressure of:	SRV461S	60 bar g
	SRV463S	24 bar g

Pressure ranges

	0.02 - 0.12 bar g
	0.10 - 0.50 bar g
	0.30 - 1.10 bar g
	0.80 - 2.50 bar g
	2.00 - 5.00 bar g
	4.00 - 8.00 bar g
	6.00 - 12.00 bar g

The SRV461S and SRV463S are available for use within the downstream pressure ranges shown.

Note: The pressure range required needs to be specified at the time of order placement:-

Permissible reduction ratio (maximum P₁ / P₂)

Setting range (bar g)	Nominal diameter	
	G1/2" - 1" DN15 - DN25	G1 1/4" - 2" DN32 - DN50
0.02 - 0.12	80:1	50:1
0.10 - 0.50	40:1	25:1
0.30 - 1.10	30:1	18:1
0.80 - 12.00	20:1	12:1

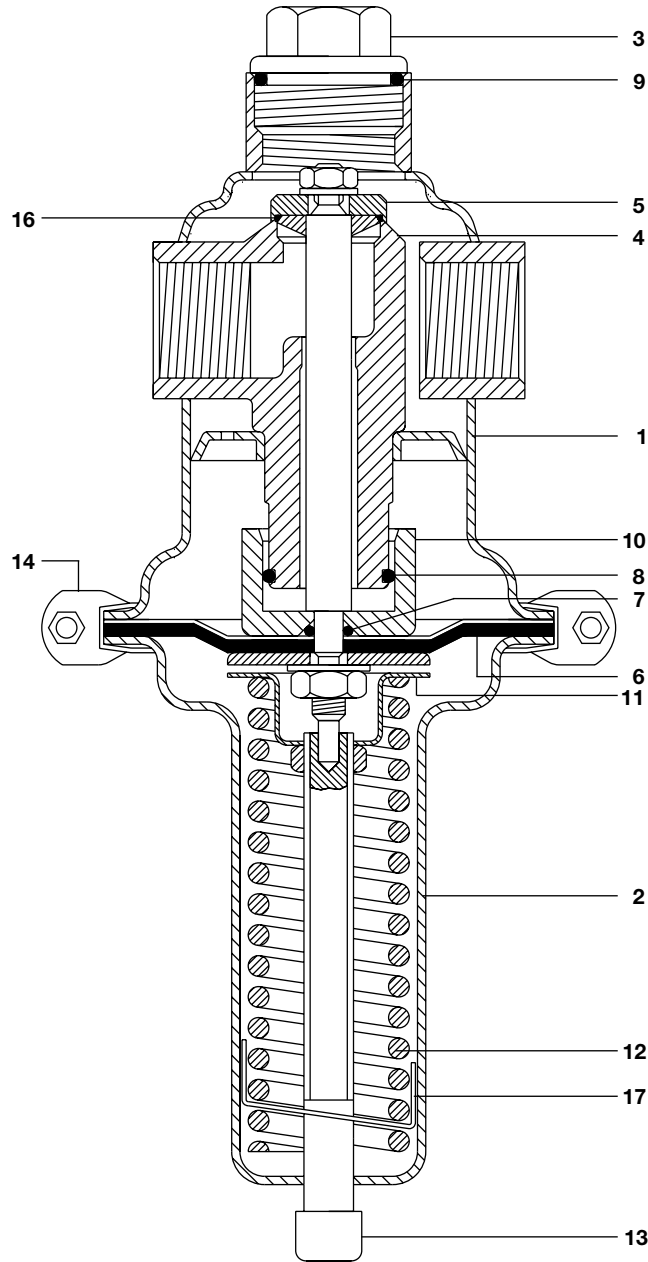

Materials

No.	Part	Material	Werkstoff No.	AISI Equivalent
1	Body	Stainless steel	1.4404	316L
2	Spring housing	Stainless steel	1.4404	316L
3	Cap	Stainless steel	1.4571	316Ti
4	Valve seat	Stainless steel	1.4404	316L
5	Valve	Stainless steel	1.4404	316L
6	Diaphragm	EPDM/PTFE		
7	'O' ring	EPDM		
8	'O' ring	EPDM		
9	'O' ring	EPDM		
10	Piston	Stainless steel	1.4571	316Ti
11	Top spring plate	Stainless steel	1.4571	316Ti
12	Spring	Stainless steel	1.4310	301*
13	Adjustment screw	Stainless steel	1.4404	316L
14	V band clamp	Stainless steel	AISI 300 series	
15	Flange (not shown)	Stainless steel	1.4404	316L
16	Soft seal	Fluoraz (FEPM) †		
17	Spring clip	Stainless steel	1.4301	304

* Not a direct equivalent, nearest AISI specification is given.

† For hydrocarbon applications an optional soft seal is available in FPM (Viton) - please consult Spirax Sarco.

Dimensions
(approximate) in millimetres

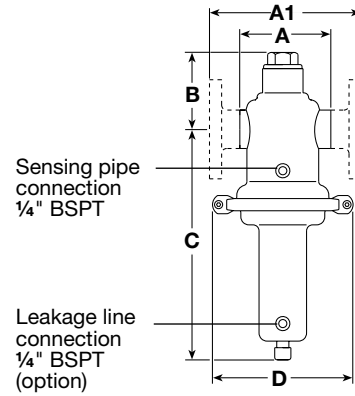
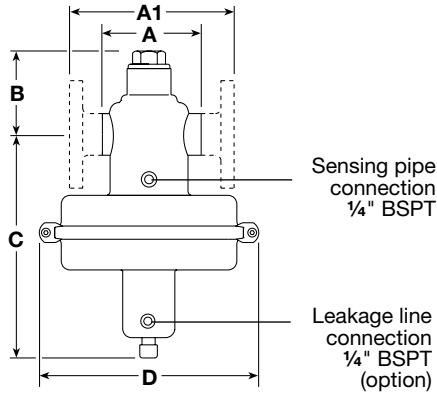

Size	All pressure ranges			Pressure range (bar)									
	A	A1	B	0.02 - 0.12		0.1 - 0.5		0.3 - 1.1		0.8 - 2.5 and 2 - 5		4 - 8 and 8 - 12	
	C	ØD	C	ØD	C	ØD	C	ØD	C	ØD	C	ØD	
DN15 1/2"	85	130	76	300	360	300	264	300	175	235	138	235	138
DN20 3/4"	91	150	76	300	360	300	264	300	175	235	138	235	138
DN25 1"	85	160	76	300	360	300	264	300	175	235	138	235	138
DN32 1 1/4"	130	180	90	300	360	300	264	300	175	235	138	235	138
DN40 1 1/2"	145	200	90	300	360	300	264	300	175	235	138	235	138
DN50 2"	185	230	90	300	360	300	264	300	175	235	138	235	138

Weights (approximate) in kg

Valve size	Connection	0.02 - 0.12	0.1 - 0.5	0.3 - 1.1	0.8 - 2.5 and 2 - 5	4 - 8 and 8 - 12
1/2" - 1"	Screwed	13.5	7.1	6.1	3.1	3.1
DN15 - DN25	Flanged	15.3	8.9	7.9	4.9	4.9
1 1/4" - 2"	Screwed	14.4	8.0	7.0	4.0	4.0
DN32 - DN50	Flanged	18.4	12.0	11.0	8.0	8.0

K_v values

Valve size	1/2" DN15	3/4" DN20	1" DN25	1 1/4" DN32	1 1/2" DN40	2" DN50
K _v at 20% offset	4.0	5.6	6.4	17.6	17.6	17.6
Maximum K _v	5.0	7.0	8.0	22.0	22.0	22.0

To maximise the control accuracy (especially for large load variations) use the K_v values given at 20% offset. For safety valve sizing use the maximum K_v values. Leakage rate ≤ 0.05% of the maximum K_v value.

Sizing and selection

The required K_v can be calculated from the following formulae,

where:

- m_s = Steam mass flow (kg/h)
- V = Liquid volume flow (m³/h)
- V_g = Gas flow at standard conditions: 0°C @ 1.013 bar a (m³/h)
- P₁ = Upstream pressure (bar absolute)
- P₂ = Downstream pressure (bar absolute)
- χ = $\frac{P_1 - P_2}{P_1}$ (pressure drop factor)
- S = Specific gravity
- T = Absolute average gas temperature (Kelvin = °C + 273)

Selecting valve type and nominal diameter

Using the required maximum flowrate and smallest differential pressure P₁ - P₂, calculate the required K_v from one of the adjacent formulae. Select a valve whose K_v value is 30% greater than the calculated K_v. The optimum working range of the selected valve should ideally be within the range of 10 to 70% of its K_v. You should also note the reduction ratio (inlet pressure P₁ divided by outlet pressure P₂). If this exceeds the quoted pressure reduction ratio for the valve being considered the valve will not close.

Steam Critical pressure drop: P₂ ≤ 0.58 P₁

$$K_v = \frac{\dot{m}_s}{12 P_1}$$

Non-critical pressure drop: P₂ ≥ 0.58 P₁

$$K_v = \frac{\dot{m}_s}{12 P_1 \sqrt{1 - 5.67 (0.42 - \chi)^2}}$$

Gas

$$K_v = \frac{\dot{V}_g}{287} \sqrt{\frac{ST}{(P_1 - P_2)(P_1 + P_2)}}$$

Liquid

$$K_v = \dot{V} \sqrt{\frac{S}{P_1 - P_2}}$$

Recommended fluid velocities	Steam	Saturated	10 to 40 m/s	Superheated	15 to 60 m/s
	Gas	up to 2 bar g	2 to 10 m/s	above 2 bar g	5 to 40 m/s
	Liquids				1 to 5 m/s

Safety information, installation and maintenance

For full details see the Installation and Maintenance Instructions (IM-P186-02) supplied with the product.

Installation note:

Note that for use on steam, the spring housing must be below the pipework. A downstream pressure sensing pipe is also required.

How to order

Example: 1 off Spirax Sarco ½" NPT SRV461S direct acting pressure reducing valve having a pressure range of 0.8 to 2.5 bar g.

Spare parts

The spare parts available are detailed below. No other parts are supplied as spares.

Available spares

Diaphragm and 'O' ring kit

6, 7, 8, 9, 16

How to order spares

Always order spares by using the description given in the column headed 'Available spares' and state the size, model and pressure range.

Example: 1 - Diaphragm and 'O' ring kit for a Spirax Sarco DN15 SRV463S direct acting pressure reducing valve with FEPM seat seal and having a pressure range of 0.8 to 2.5 bar g.

