



Cert. No. LRQ 0963008

ISO 9001

# spirax sarco

**TI-P133-08**  
ST Issue 12

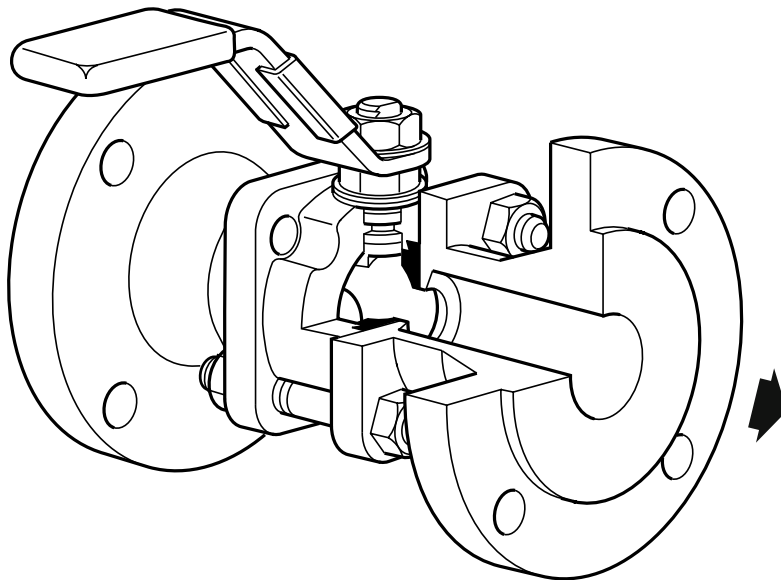
**M10V**
**Ball Valve**
**DN $\frac{1}{4}$ " to 2 $\frac{1}{2}$ "**

## Description

The M10V three-piece body ball valve has been designed for use as an isolating valve, not a control valve, and can be serviced without removal from the pipeline (screwed and welded versions only). It can be used with the majority of industrial fluids.

### Available types

**M10V2**\_ \_ Zinc plated carbon steel body, PTFE seats.

**M10V3**\_ \_ Stainless steel body, PTFE seats.

**M10V4**\_ \_ Complete stainless steel, PTFE seats.

**Note:** The nomenclature will be followed with either **FB** (full bore) or **RB** (reduced bore).

### Standards

This product fully complies with the requirements of the European Pressure Equipment Directive 97/23/EC and carries the **CE** mark when so required.

### Certification

This product is available with certification to EN 10204 3.1.

**Note:** All certification / inspection requirements must be stated at the time of order placement.

## Sizes and pipe connections

### Full bore

$\frac{1}{4}$ ",  $\frac{3}{8}$ ",  $\frac{1}{2}$ ",  $\frac{3}{4}$ ", 1", 1 $\frac{1}{4}$ ", 1 $\frac{1}{2}$ " and 2"

### Screwed and welded

BSP, BSPT, API/NPT, BW, SW

### Flanged

DN15 to DN50  
ASME (ANSI) Class 150,  
ASME (ANSI) Class 300,  
and EN 1092 PN40.

### Reduced bore

$\frac{1}{4}$ ",  $\frac{3}{8}$ ",  $\frac{1}{2}$ ",  $\frac{3}{4}$ ", 1", 1 $\frac{1}{4}$ ", 1 $\frac{1}{2}$ ", 2" and 2 $\frac{1}{2}$ "

### Screwed and welded

BSP, BSPT, API/NPT, BW, SW

### Flanged

DN15 to DN65  
ASME (ANSI) Class 150,  
ASME (ANSI) Class 300,  
and EN 1092 PN40.

## Technical data

Flow characteristic Modified linear

Port Full and reduced port versions

Leakage test procedure to ISO 5208 (Rate A) / EN 12266-1 (Rate A)

Antistatic device Complies with ISO 7121 and BS 5351

## Pressure / temperature limits

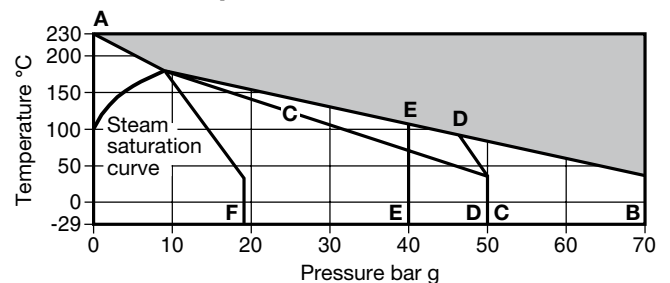

■ The product **must not** be used in this region.

**A - B** Screwed, SW and BW  $\frac{1}{4}$ " -  $\frac{1}{2}$ " FB, RB and 2" RB.

**A - C** Screwed, SW and BW 2" FB and 2 $\frac{1}{2}$ " RB only.

**A - D** Flanged ASME (ANSI) 300.

**A - E** Flanged EN 1092 PN40.

**A - F** Flanged ASME (ANSI) 150.

**Note 1:** On the 2" FB and 2 $\frac{1}{2}$ " RB a PTFE gasket is fitted between the body and cap.

**Note 2:** The flange standard may restrict the maximum operating pressure. Please check with Spirax Sarco.

Body design conditions		PN100
PMA	Maximum allowable pressure	70 bar g @ 40°C
TMA	Maximum allowable temperature	230°C @ 0 bar g
Minimum allowable temperature		-29°C
PMO	Maximum operating pressure for saturated steam service	10 bar g
TMO	Maximum operating temperature	230°C @ 0 bar g
Minimum operating temperature		-29°C
<b>Note:</b> For lower operating temperatures consult Spirax Sarco		
$\Delta$ PMX		Maximum differential pressure is limited to the PMO
Designed for a maximum cold hydraulic test pressure of 105 bar g		

Local regulations may restrict the use of this product to below the conditions quoted.

In the interests of development and improvement of the product, we reserve the right to change the specification without notice.

© Copyright 2010

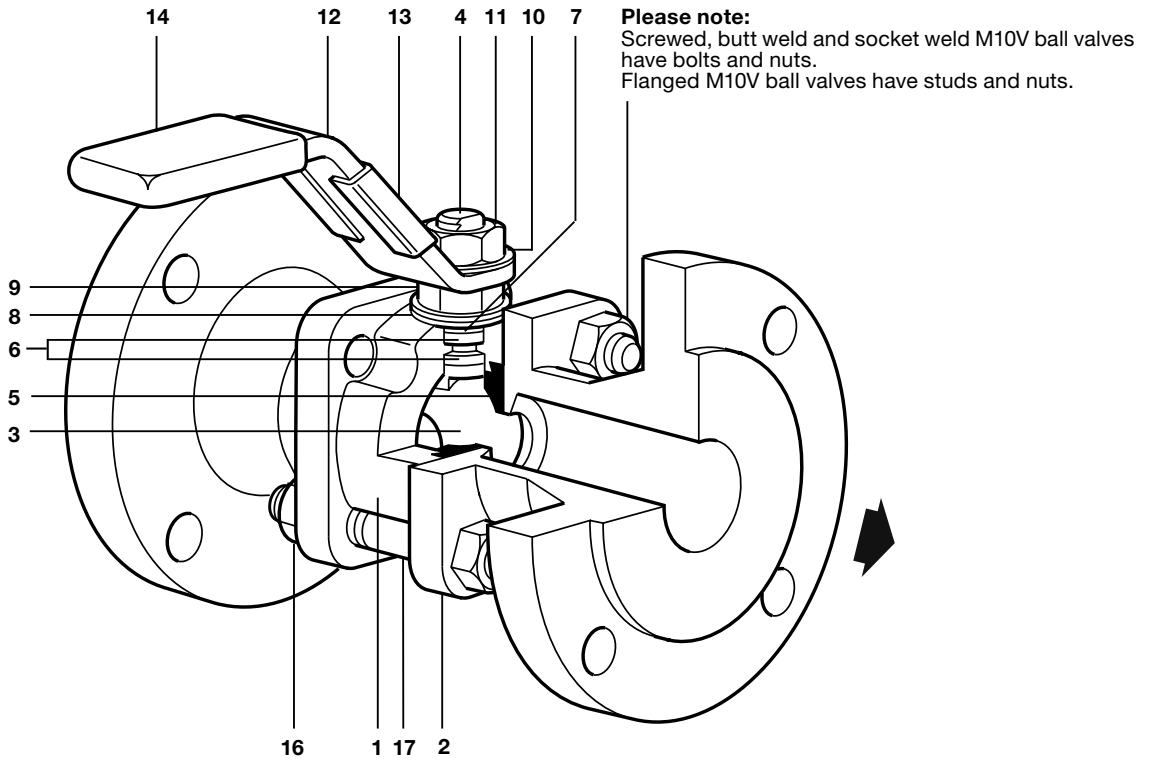

**Materials**

No. Part		Material		
1	Body	M10V2	Zinc plated carbon steel	ASTM A105
		M10V3	Stainless steel	ASTM A 182 F 316L
		M10V4		
2	Cap	M10V2	Zinc plated carbon steel	ASTM A105
		M10V3	Stainless steel	ASTM A 182 F 316L
		M10V4		
3	Ball	Stainless steel	AISI 316	
4	Stem	Stainless steel	AISI 316	
5	Seat	Virgin PTFE		
6	Stem seal	Reinforced PTFE antistatic		
7	Separator	M10V2	Zinc plated carbon steel	ASTM A105
		M10V3	Stainless steel	AISI 316
		M10V4		
8	Spring washers	Stainless steel	AISI 301	
9	Nut	M10V2	Zinc plated carbon steel	SAE 12L14
		M10V3	Stainless steel	AISI 304
		M10V4		
10	Name-plate (DN)	Stainless steel	AISI 430	
11	Stem nut	M10V2	Zinc plated carbon steel	SAE 12L14
		M10V3	Stainless steel	AISI 304
		M10V4		
12	Lever	M10V2	Zinc plated carbon steel	SAE 1010
		M10V3	Stainless steel	AISI 316
		M10V4		
13	Name-plate	Stainless steel	AISI 430	
14	Grip	Vinyl		
* 15	Bolts	M10V2	Zinc plated carbon steel	A 193 B7
		M10V3	Stainless steel	AISI 304
		M10V4		
16	Nuts	M10V2	Zinc plated carbon steel	SAE 1010
		M10V3	Stainless steel	AISI 304
		M10V4		
17	Studs	M10V2	Zinc plated carbon steel	Grade 5
		M10V3	Stainless steel	AISI 316
		M10V4		

\* Note: Item 15 not shown - Screwed, butt weld and socket weld versions only

**Dimensions (approximate) in mm****Reduced bore**

Size	A	A1	A2	A3	A4	B	B1	C	C1	D	D1	D2	D3	E
¼"	63	60	-	-	-	120	-	61	-	22	-	-	-	11
⅜"	63	63	-	-	-	120	-	61	-	22	-	-	-	11
½"	63	51	108	130	140	120	120	61	87	24	89	95	95	11
¾"	68	59	117	150	152	120	120	63	89	26	98	105	117	14
1"	86	84	127	160	165	157	157	91	91	31	108	115	124	21
1¼"	97	93	140	180	178	157	157	95	95	37	118	140	133	25
1½"	106	102	165	200	190	180	180	109	109	41	127	150	156	31
2"	124	118	178	230	216	180	180	115	115	48	152	165	165	38
2½"	152	152	191	-	241	245	-	132	132	57	-	-	190	51

**Full bore**

Size	A	A1	A2	A3	A4	B	B1	C	C1	D	D1	D2	D3	E
¼"	63	60	-	-	-	120	-	61	-	24	-	-	-	11
⅜"	63	63	-	-	-	120	-	61	-	24	-	-	-	11
½"	68	68	-	130	140	120	120	63	89	26	-	95	95	14
¾"	86	86	-	150	152	157	157	91	91	31	-	105	117	21
1"	97	97	-	160	165	157	157	95	95	37	-	115	124	25
1¼"	106	106	-	180	178	180	180	109	109	41	-	140	133	31
1½"	124	124	-	200	190	180	180	115	115	48	-	150	156	38
2"	152	152	-	230	216	245	245	132	132	57	-	165	165	51

**Weights (approximate) in kg**

Size	Reduced bore				Full bore		
	Scrd / BW / SW	PN40	ASME 150	ASME 300	Scrd / BW / SW	PN40	ASME 300
¼"	0.61	-	-	-	0.61	-	-
⅜"	0.61	-	-	-	0.61	-	-
½"	0.61	2.2	1.65	2.2	0.70	2.3	2.5
¾"	0.70	2.9	2.20	2.9	1.27	3.5	4.2
1"	1.27	3.9	3.38	4.5	1.77	4.4	5.1
1¼"	1.77	5.4	4.44	7.0	2.50	6.2	7.5
1½"	2.50	6.5	5.84	8.36	3.50	7.5	10.0
2"	3.50	8.8	8.99	11.2	6.90	12.2	13.4
2½"	6.90	-	-	17.5	-	-	-

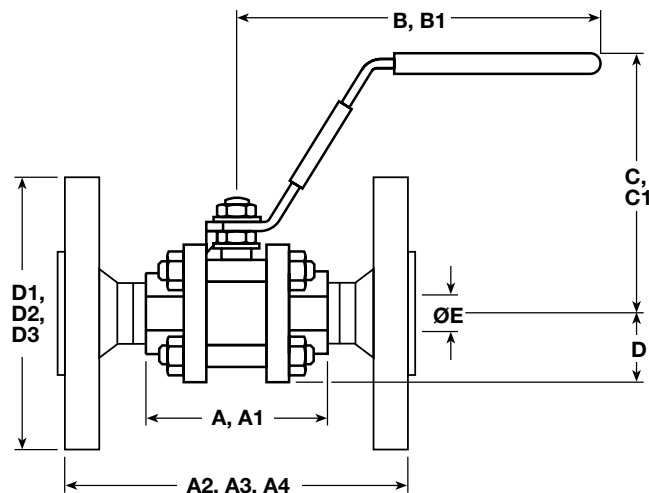

- A** : Screwed and Butt weld  
**A1** : Socket weld  
**A2** : Flanged ASME (ANSI) 150  
**A3** : Flanged PN40  
**A4** : Flanged ASME (ANSI) 300  
**B** : Screwed, Butt weld and Socket weld  
**B1** : Flanged ASME (ANSI) 150, PN40  
**C** : Screwed, Butt weld and Socket weld  
**C1** : Flanged ASME (ANSI) 150, Flanged PN40  
**D** : Screwed, Butt weld and Socket weld  
**D1** : Flanged ASME (ANSI) 150  
**D2** : Flanged PN40  
**D3** : Flanged ASME (ANSI) 300

**K<sub>v</sub> values**

Size	1/4"	3/8"	1/2"	3/4"	1"	1 1/4"	1 1/2"	2"	2 1/2"
Reduced bore	2.5	2.5	6	10	27	49	70	103	168
Full bore	2.5	6.8	17	36	58	89	153	205	-

For conversion: C<sub>v</sub> (UK) = K<sub>v</sub> x 0.963      C<sub>v</sub> (US) = K<sub>v</sub> x 1.156

**Operating torque (N m)**

Size	1/4"	3/8"	1/2"	3/4"	1"	1 1/4"	1 1/2"	2"	2 1/2"
Reduced bore	2	2	2	3.5	13	21	30	40	45
Full bore	2	2	3.5	13	21	30	40	45	-

The indicated torque values are for valves frequently operated, that are submitted to a maximum differential pressure of 62 bar. Valves that are subject to long static periods, may require greater break-out torque.

**Safety information, installation and maintenance**

For full details see the Installation and Maintenance Instructions supplied with the product.

**How to order example:**

1 off Spirax Sarco 1/2" screwed BSP M10V2FB ball valve.

**Optional extras:**

- Self-venting ball.
- Extended stems 50 mm (2") and 100 mm (4") to allow full insulation.
- Lockable handle.
- Oval handle for confined spaces. Ideal for trap modules.

**Spare parts**

The spare parts available are shown in solid outline. Parts drawn in broken line are not supplied as spares.

**Available spares**

Seat and stem seal set	<b>5, 6</b>
------------------------	-------------

**How to order spares**

Always order spares by using the description given in the column headed 'Available spares' and state the size and type of ball valve.

**Example:** 1 - Seat and stem seal set for a 1/2" M10V2FB ball valve.

