



Cert. No. LRQ 0963008

ISO 9001

spirax sarco

TI-P102-01
 CH Issue 4

37D and 37DE Pilot Operated

Temperature Control Valve with SG Iron Body

Description

The 37D is a pilot operated temperature control valve suitable for use on steam applications and comes complete with 2 m of capillary tube as standard (other lengths are available on request - see Optional extras).

By virtue of its pilot operation, it has a comparatively small control band.

The sensor of the control system will need to be mounted by either a union kit, pocket or wall mounting bracket - see 'Optional extras'.

Available types of valve

37D Temperature control

37DE Temperature control with electrically operated solenoid valve

Note: For optional extras see overleaf.

Sizes and pipe connections

1/2" LC, 1/2", 3/4" and 1" screwed BSP (BS 21 parallel) or NPT.
 DN15LC, DN15, DN20, DN25, DN32, DN40 and DN50 flanged:

Standard flanges	DN15 - DN20	BS 4504/DIN PN25
	DN25 - DN50	BS 10 Table H and ANSI 300
Also available	DN15 - DN50	JIS 10/16 and ANSI 150
	DN15 - DN20	BS 10 Table F
	DN15	ANSI 300

Temperature ranges

Range A	16°C to 49°C
Range B	38°C to 71°C
Range C	49°C to 82°C
Range D	71°C to 104°C
Range E	93°C to 127°C

Limiting conditions

Maximum body design conditions	25 bar @ 120°C
	20 bar @ 250°C
	14 bar @ 350°C
Maximum upstream conditions	37D 17 bar @ 232°C
	37DE 10 bar @ 190°C
Designed for a maximum cold hydraulic test pressure of 38 bar g	

Technical data

Voltages available	220/240 ± 10% Vac or 110/120 ± 10% Vac (others available on request)	
Frequency	50/60 Hz	
Power consumption	Inrush	45 VA
	Holding	23 VA

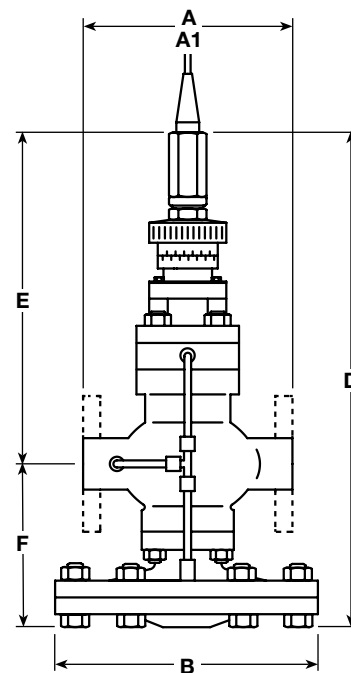

Union kit

Metal pocket

Wall mounting

Glass pocket

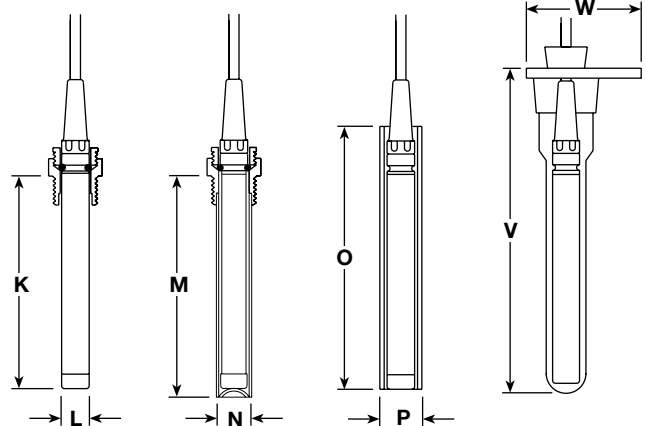

Dimensions/weights (approximate) in mm and kg

Size	Screwed	BS 10 H	PN25	ANSI 300	BS 10 F	ANSI 150	JIS 10/16	B	D	E	F	Weight	
	A	A1	A1	A1	A1	A1	A1					Screwed	Flanged
DN15LC	160	-	130	126.6	117	120.2	122	185	408	278	130	12.0	12.8
DN15	160	-	130	126.6	117	120.2	122	185	408	278	130	12.0	12.8
DN20	160	-	150	-	133	139.4	142	185	408	278	130	12.0	13.7
DN25	180	160	160	160	-	160.0	152	207	432	284	148	13.0	16.0
DN32	-	180	180	180	-	176.0	176	207	432	284	148	-	17.0
DN40	-	200	200	200	-	199.0	196	255	476	298	178	-	29.0
DN50	-	230	230	230	-	228.0	222	255	476	298	178	-	31.5

K	L	M	N	O	P	V	W
142	17.5	150	22.3	195	35	575	117

Local regulations may restrict the use of this product to below the conditions quoted.

In the interests of development and improvement of the product, we reserve the right to change the specification without notice.

© Copyright 2006

Materials

No.	Part	Material	
14	Internal strainer	Stainless steel	BS 1449 304 S 16
15	Body gasket	Reinforced exfoliated graphite	
16	Main valve return spring	Stainless steel	BS 2056 302 S 25
17	Main valve	Stainless steel	BS 970 431 S 29
18	Main valve seat	Stainless steel	BS 970 431 S 29
20	Main valve body	SG iron	DIN 1693 GGG 40.3
21	Main body securing studs and nuts	Steel (M10 x 25 mm)	BS 4439 Gr. 8.8 BS 1492 Gr. 8
22	Main diaphragm chamber	SG iron	DIN 1693 GGG 40.3
23	Main diaphragm securing bolts and nuts	Steel (M12 x 50 mm)	BS 1492 Gr. 8.8 BS 1492 Gr. 8
24	Main diaphragms	Phosphor bronze	BS 2870 PB 102
25	Main diaphragm plate	Brass	BS 2872 CZ 122
26	Push rod	Stainless steel	BS 970 431 S 29
27	Pipe assembly	Brass and copper	
28	Plug 1" BSP	Steel	
30	Lock-nut	Steel	BS 1492 Gr. 8
34	Packless gland housing	Brass	BS 2874 CZ 121
35	Pilot valve plunger	Bakelite symmould	S 67S
36	Pilot valve seat ring	Stainless steel	BS 970 431 S 29
37	Pilot valve closure member	Stainless steel	AISI 440 B
38	Pilot valve housing	SG iron	DIN 1693 GGG 40.3
39	Pilot valve housing securing studs and nuts	Steel (M10 x 25 mm)	BS 4439 Gr. 8.8 BS 1492 Gr. 8
40	Locking ring	Brass	BS 2874 CZ 121
41	Control head	Bakelite symmould	S 67S
42	Control head securing screws	Stainless steel (2 BA x ¾")	
43	Capillary tube	Copper PVC covered	
44	Sensor	Brass	EN 12451 CW707R H130/170

Optional extras

Conversion kit: A standard kit comprising of a solenoid valve and the necessary pipe and fittings for converting an existing 37D to a 37DE temperature control valve.

Capillary tubes: Available in multiples of 2 m up to a max. of 14 m.

Union kit: Comprising of union nipple (U), compression ring (V) and a gland nut (W). The union nipple is screwed ¾" BSP.

Pockets: Are available in copper with brass union nipple or stainless steel. Union nipple U forms the top of the pocket and carries compression ring V and gland nut W. The union nipple is screwed ¾" BSP.

Special long pockets are available having minimum length of 0.5 m and a maximum of 1 m. They are sealed at the top by a rubber bung. Glass pockets are also available complete with bracket and sealed by a rubber bung.

Wall mounting bracket: Inclusive of cover.

Safety information, installation and maintenance

For full details see the Installation and Maintenance Instructions (IM-P102-04) supplied with the product.

How to order

Example: 1 off Spirax Sarco DN20 37D pilot operated temperature control valve having a temperature range A. The flange connections are to be ANSI 300.

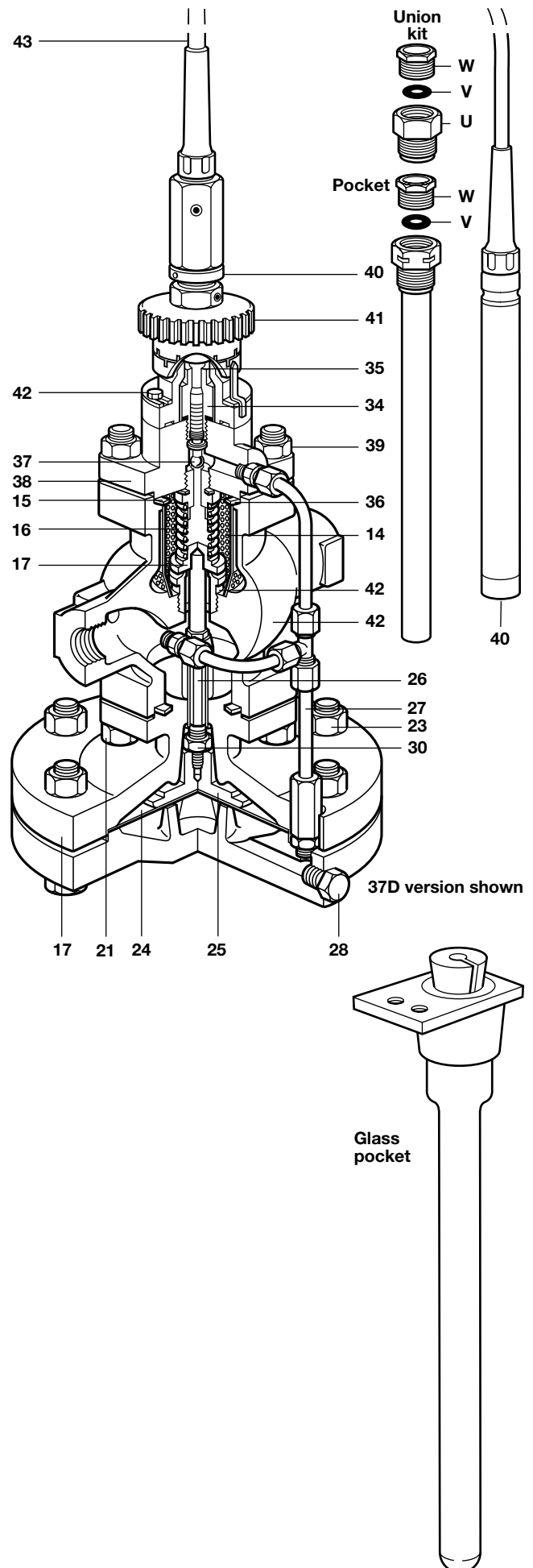

Steam capacities in kg/h

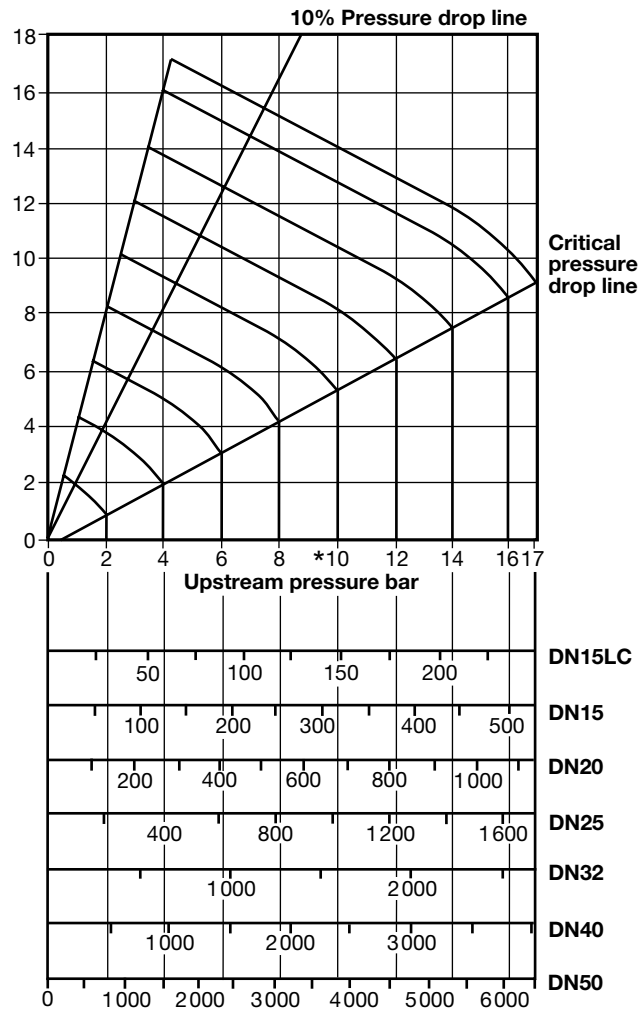

* **Note:**
The 37DE is limited to a maximum pressure of 10 bar.

Kv values

Size	Kvs
DN15LC	1.0
DN15	2.8
DN20	5.5
DN25	8.1
DN32	12.0
DN40	17.0
DN50	28.0

The capacity varies for both the 37D and 37DE according to the pressure drop across them. The chart above enables the capacity to be read off for different pressure drops. The maximum capacity occurs when the downstream pressure is at, or below 58% of the absolute upstream pressure (Critical pressure drop). For many applications, valves can be satisfactorily sized on 10% pressure drop, i.e. with a downstream which is 90% of the absolute upstream and a 10% pressure drop line is included in the chart to allow this to be done easily.

How to use the chart

The way in which the chart is used is explained by examples:

Example 1. Firstly, to find the size of control valve required to pass 200 kg/h with an upstream pressure of 8 bar and a permissible pressure drop of 2 bar (downstream pressure = 6 bar)

Find the point at which the curved 8 bar upsteam pressure line intersects a horizontal line drawn from a downstream pressure of 6 bar and read vertically downwards. It will be seen that a DN15 valve will pass 200 kg/h and is the correct size to choose.

Example 2. A DN50 valve is operating on an upstream pressure of 10 bar and has to pass 3 500 kg/h. It is required to know the downstream pressure and hence the pressure drop across the valve.

The flowrate 3 500 kg/h is read off the horizontal line at the bottom of the chart giving the capacity of the DN50 valve using the vertical guide line read upwards from the 3 500 kg/h figure until you strike the curved 10 bar upstream pressure line and from this point read horizontally to the left to meet the downstream pressure scale. This is at the 7 bar reading and the pressure drop across the DN50 valve when passing 3 500 kg/h of steam is 3 bar giving a downstream pressure of 7 bar.

Example 3. Finally, if a 10% pressure drop is satisfactory and a valve is required to pass 1 000 kg/h with an upstream pressure of 14 bar find the point where the 14 bar curved upstream pressure line intersects the 10% pressure drop line. From this point read vertically downwards and it will be seen that a DN32 valve is the correct size.

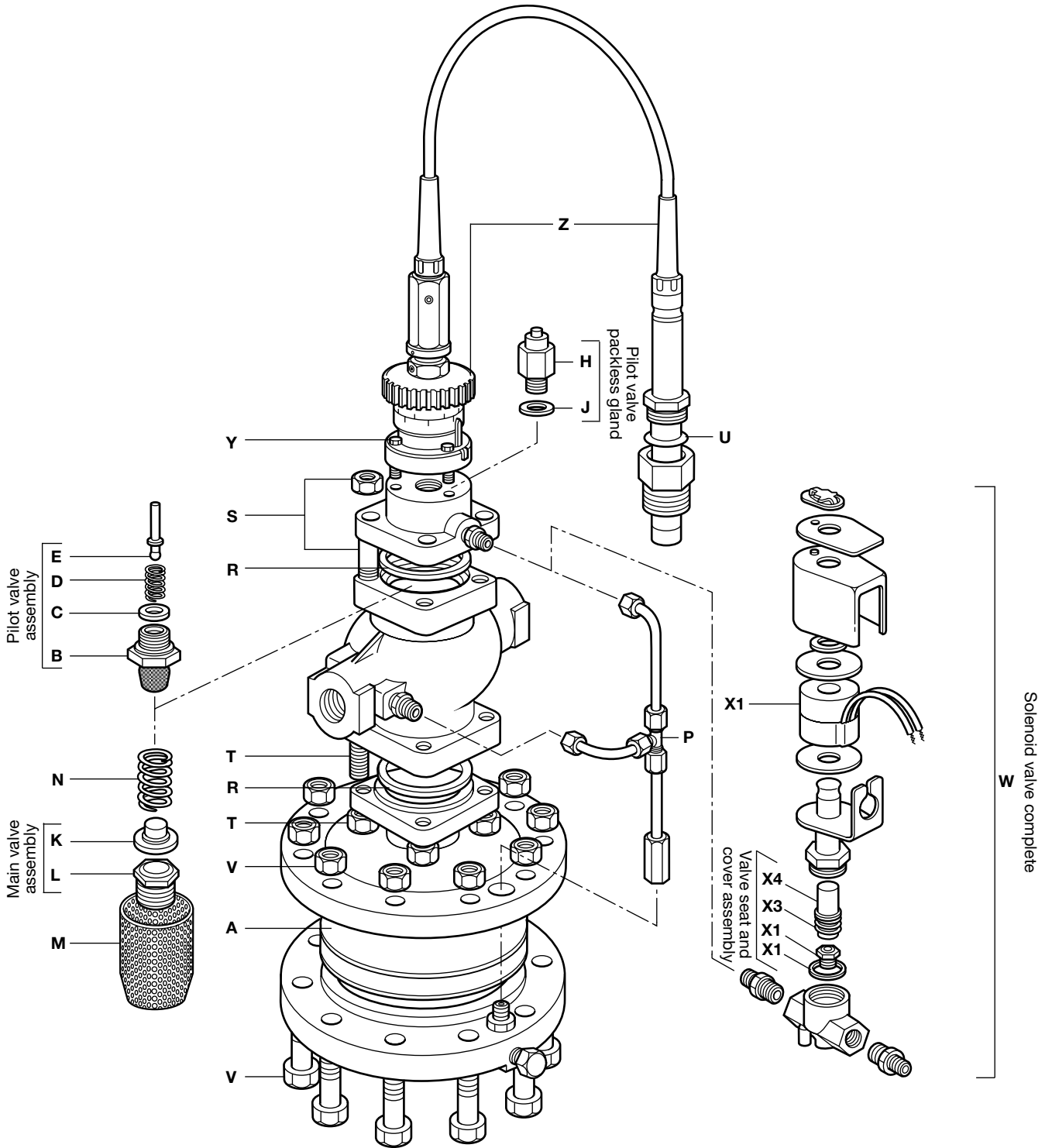

Spare parts

Available spares

Maintenance kit

A stand-by set of spares for general maintenance purposes and covers all spares marked *

* Main diaphragm	(2 off)	A
Pilot valve assembly		B, C, D, E
* Pilot valve packless gland set		H, J
Main valve assembly		K, L
* Internal strainer		M
* Main valve return spring		N
Control head		Z, (3 off) Y
When ordering state range and length of capillary tube. Normally stocked in capillary lengths of 2 m. Available in multiples of 2 m up to a maximum of 14 m (at extra cost).		
Range A 16°C – 49°C	Range B 38°C – 71°C	Range C 49°C – 82°C
Range D 71°C – 104°C	Range E 93°C – 127°C	
'O' ring for sensor bulb adaptor	(packet of 3)	U
* Control pipe assembly		P
* Gasket set	(3 off)	R
Set of pilot valve housing securing stud and nuts	(Set of 4)	S
Set of main body studs and nuts	(Set of 4)	T
Set of diaphragm securing bolts and nuts	Valve sizes: DN15 to DN32 (Set of 10) DN40 to DN50 (Set of 12)	V
Set of control head securing screws	(set of 3)	Y
Solenoid valve type 37DE only		W
Coil		X1
Valve seat and core assembly		X2, X3, X4, X5

How to order

Always order spares by using the description given in the column headed 'Available spares' and state the size and type (37D or 37DE) of temperature control valve and whether screwed or flanged.

Example: 1 - Main valve assembly for a Spirax Sarco DN25 Type DP37D temperature control valve.

How to fit

See the Installation and Maintenance Instructions supplied with the product. Further copies are available on request.

Interchangeability of spares

The following table shows how in certain sizes some parts are interchangeable. For example in the line headed 'Main diaphragm' the diaphragm used in the screwed valves ½" and ¾" is common to these sizes by the letter 'a', the letter 'c' indicates that one diaphragm is common to the DN40 and DN50 valves. All spares marked † are interchangeable with the DP17 pressure reducing valve. Spares marked 'o' are interchangeable with the DP17T and DP17TE pilot operated pressure/temperature control valves.

Size DN	Screwed				Flanged							
	½"LC	½"	¾"	1"	15LC	15	20	25	32	40	50	
Maintenance kit	a	a	a	b	f	f	a	b	c	d	e	
† o Main diaphragm	a	a	a	b	a	a	a	b	b	c	c	
† o Pilot valve assembly	a	a	a	a	a	a	a	a	a	a	a	
† o Pilot valve packless gland set	a	a	a	a	a	a	a	a	a	a	a	
† o Main valve assembly	a	b	c	d	a	b	c	d	e	f	g	
† o Internal strainer	a	a	a	b	f	f	a	b	c	d	e	
† o Main valve return spring	a	a	a	b	a	a	a	b	b	c	c	
o Control head	a	a	a	a	a	a	a	a	a	a	a	
o 'O' ring for sensor bulb adaptor	a	a	a	a	a	a	a	a	a	a	a	
Control pipe assembly	a	a	a	b	f	f	a	b	c	d	e	
† Gasket set	a	a	a	a	a	a	a	a	a	b	b	
† Set of pilot valve housing securing studs and nuts	a	a	a	a	a	a	a	a	a	b	b	
† o Set of main body studs and nuts	a	a	a	a	a	a	a	a	a	b	b	
† o Set of diaphragm securing bolts and nuts	a	a	a	a	a	a	a	a	a	b	b	
† o Set of control head securing screws	a	a	a	a	a	a	a	a	a	a	a	