

spirax sarco

TI-P078-02
CH Issue 10

KA31, KA33, KB31, KB33 and KC31 Cast Iron Self-acting Control Valves

Description

The KA, KB and KC range of two-port valves are used in conjunction with Spirax Sarco SA control systems to provide a self-acting temperature control unit.

Alternatively, they can be used as electrically actuated temperature control valves by fitting an EL7200 Series electric actuator with a suitable temperature transmitter and controller.

Available types

KA31 Normally open with screwed connections.

KA33 Normally open with flanged connections.

KB31 Normally open with phosphor bronze balancing bellows and screwed connections.

KB33 Normally open with phosphor bronze balancing bellows and flanged connections.

KC31 Normally open with stainless steel balancing bellows and screwed connections.

Note: Pressure balancing bellows enables the valve to operate against higher differential pressures.

Standards

These products fully comply with the requirements of the European Pressure Equipment Directive 97/23/EC and carry the **CE** mark when so required.

Certification

As standard these products are available with a manufacturers' Typical Test Report. **Note:** All certification/inspection requirements must be stated at the time of order placement.

Pressure / temperature limits

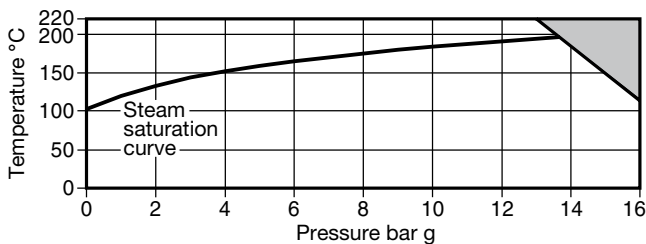

The product must not be used in this region.

Body design conditions	PN16					
Maximum design pressure	16 bar g @ 120°C					
Maximum design temperature	220°C @ 13.8 bar g					
Minimum design temperature	-10°C					
Maximum operating temperature	220°C					
Minimum operating temperature	0°C					

Note: For lower operating temperatures consult Spirax Sarco

	Size	DN15	DN20	DN25	DN32	DN40	DN50
Maximum differential pressure bar	KA31	13.0	10.3	4.5	3.0	2.0	1.5
	KA33	13.0	10.3	4.5	3.0	2.0	1.5
	KB31	-	-	10.3	9.0	8.2	6.9
	KB33	-	-	10.3	9.0	8.2	6.9
	KC31	-	-	-	-	13.0	13.0

Designed for a maximum cold hydraulic test pressure of 24 bar g

Sizes and pipe connections

Screwed BSP (BS 21 parallel) or NPT:

KA31 ½", ¾", 1", 1¼", 1½" and 2"

KB31 1", 1¼", 1½" and 2"

KC31 1½" and 2"

Flanged EN 1092 PN16 and BS 10 Table F:

KA33 DN15, DN20, DN25, DN32, DN40 and DN50

KB33 DN25, DN32, DN40 and DN50

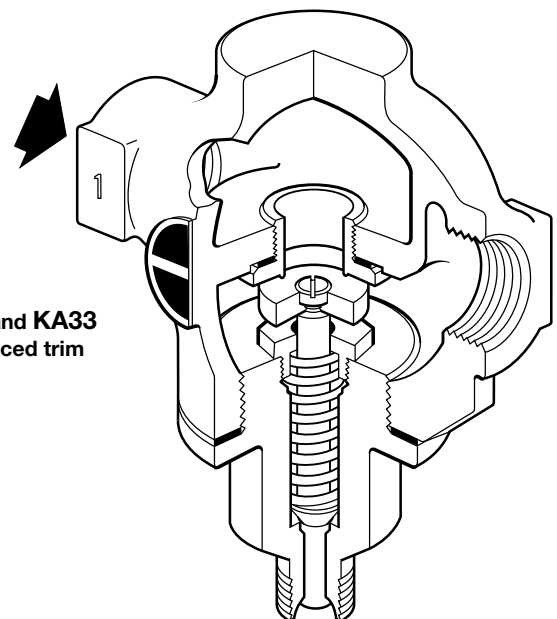

**KA31 and KA33
unbalanced trim**

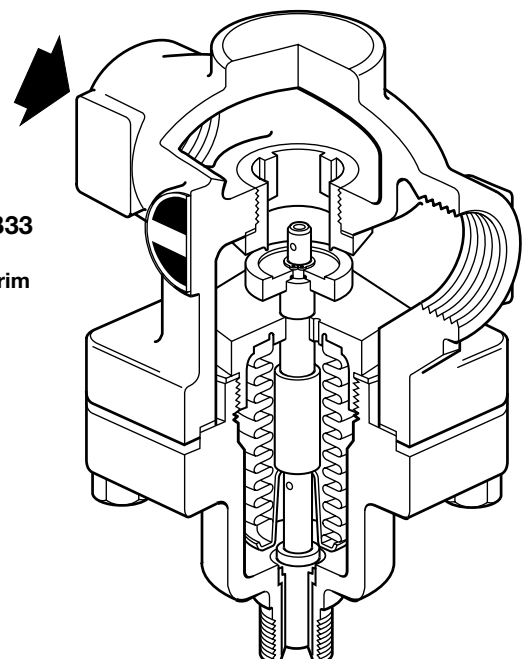

**KB31, KB33
and KC31
balanced trim**

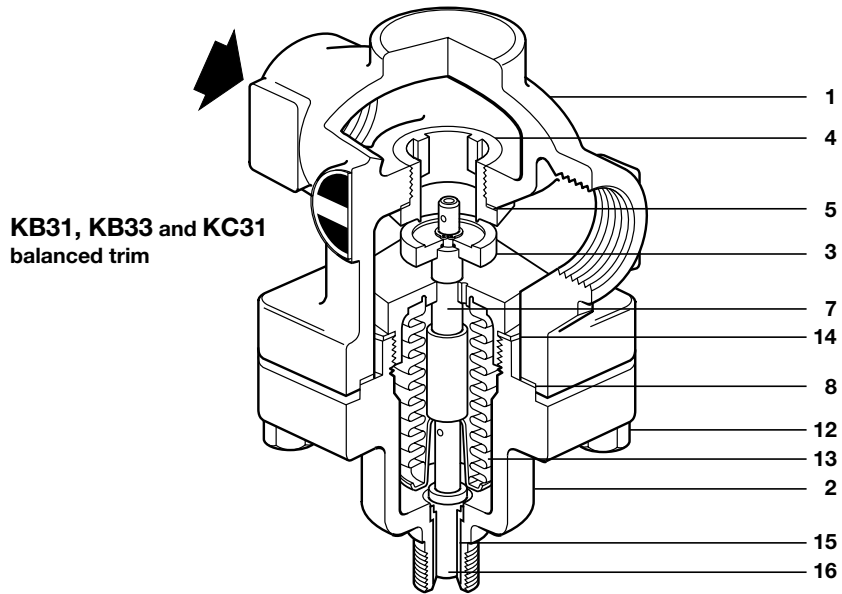
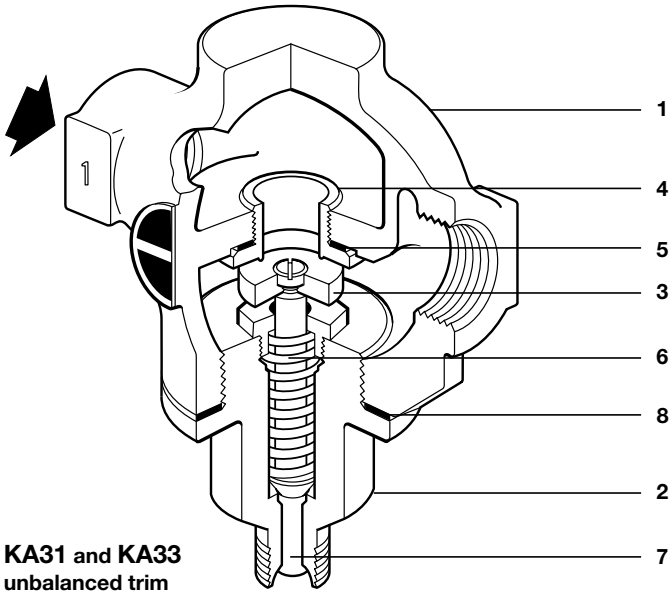

Materials

No. Part		Material	
1	Body	Cast iron	DIN 1691 GG 25
	KA and KB	Cast iron	DIN 1691 GG 25
2	Bonnet	Cast iron	DIN 1691 GG 25
	KC - 1½"	Cast iron	DIN 1691 GG 25
	KC - 2"	Steel	EN 10213 GP240 GH+N
3	Valve head	Stainless steel	BS 970 431 S 29
4	Valve seat ring	Stainless steel	BS 970 431 S 29
5	Valve seat gasket	Mild steel	BS 1449 CS 4
	DN15 - DN25	Reinforced exfoliated graphite	
	DN32 - DN50		
6	Return spring	Stainless steel	BS 2056 302 S 26
7	Stem	Brass	BS 2874 CZ 121
	KA and KB	Stainless steel	BS 970 321S20
	KC		
8	Bonnet gasket	Reinforced exfoliated graphite	
12	Bonnet studs	Steel	BS 4439 Gr. 8.8
	Bonnet nuts	Steel	BS 3692 Gr. 8
13	Bellows	Phosphor bronze	EN 12449 Cu Sn 6
	KB	Stainless steel	AISI 316 L
	KC		
14	Bellows gasket	Reinforced exfoliated graphite	
15	Bonnet bush	Brass	BS 2874 CZ 121
16	Plunger	Brass	BS 2874 CZ 121

K_v values

Size	DN15	DN20	DN25	DN32	DN40	DN50
KA31, KA33	2.90	4.64	9.80	16.48	23.70	34.00
KB31, KB33	-	-	9.80	16.48	23.70	34.00
KC31	-	-	-	-	16.48	34.00

For conversation: $C_v (UK) = K_v \times 0.963$ $C_v (US) = K_v \times 1.156$

Capacities

For saturated steam sizing capacities see TI-GCM-08.
For water valve sizing capacities see TI-GCM-09.

**Dimensions/weights (approximate) in mm and kg
KA31 and KA33**

Size	PN16		BS 10'F'		Weight		
	A	A1	A1	B	C	Scr.	Fig.
DN15-1/2"	90	130	130	105	37	1.3	3.3
DN20-3/4"	104	150	147	105	37	1.6	4.3
DN25-1"	136	160	157	107	51	3.2	5.7
DN32-1 1/4"	144	180	180	110	-	5.1	8.8
DN40-1 1/2"	150	200	200	110	-	6.3	11.0
DN50-2"	180	230	230	110	-	7.8	13.0

KB31, KB33 and KC31

DN25-1"	136	160	157	138	51	3.4	5.9
DN32-1 1/4"	144	180	180	152	51	5.7	9.1
DN40-1 1/2"	150	200	200	152	62	6.9	11.2
DN50-2"	180	230	230	152	71	8.8	13.4

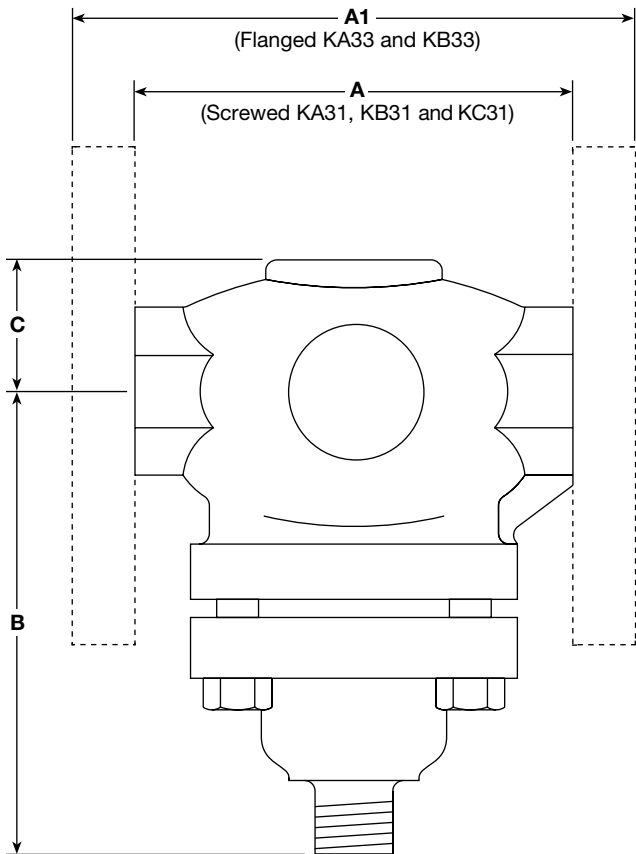

Spare parts

The spare parts available are shown in solid outline. Parts drawn in broken line are not supplied as spares.

Available spares

KA31 and KA33

Valve seat assembly	A, D, E, L
Set of all gaskets	E, L
Set of bonnet studs and nuts (set of 4)	S

KB31, KB33 and KC31

Valve seat assembly (excluding bellows and stem assembly)	A, B, C, D, E, L, U, G
Bellows and stem assembly	G, L, N, H
Set of all gaskets	B, C, E, L, U, G
Set of bonnet studs and nuts (set of 4)	S

How to order spares

Always order spares by using the description given in the column headed 'Available spares' and state the size and type of valve.

Example: 1 - Valve seat assembly for a Spirax Sarco DN32 KB31 self-acting control valve.

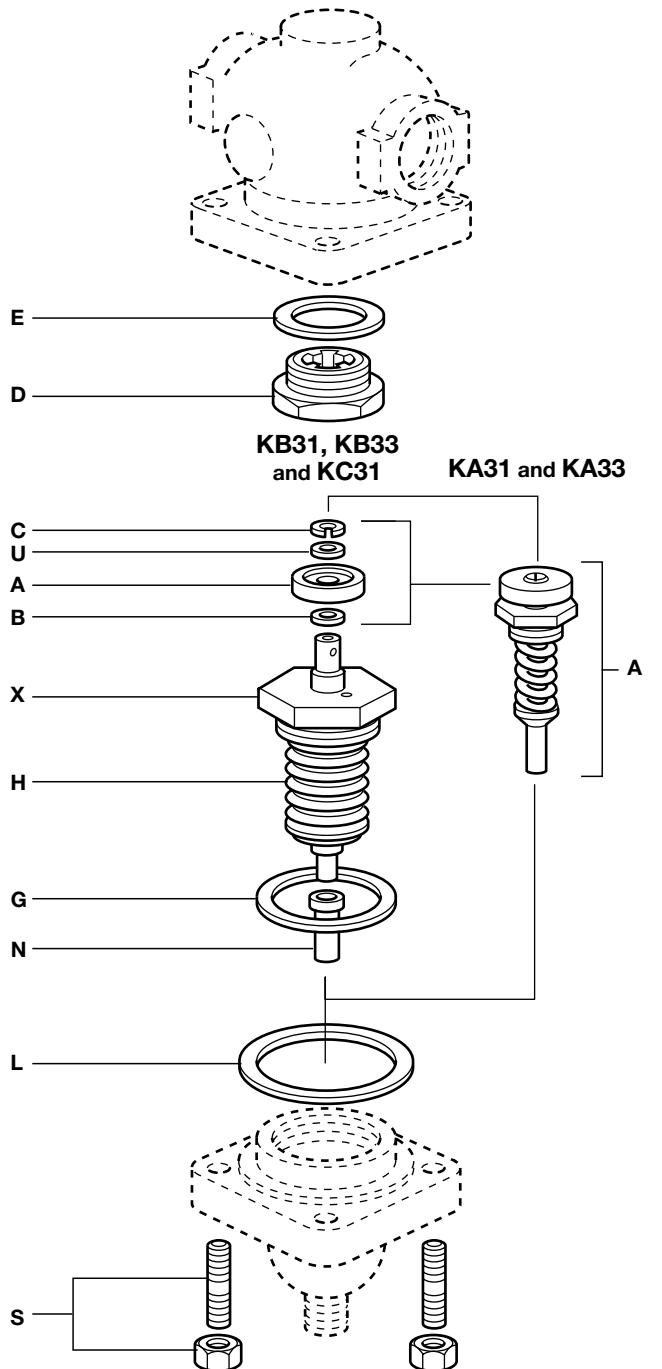

Safety information, installation and maintenance

For full details see the Installation and Maintenance Instructions (IM-S21-01) supplied with the product.

Installation note:

The valve should be fitted in a horizontal line with the actuator vertically below the pipeline.

How to order

Example: 1 off Spirax Sarco 1 1/4" screwed BSP KA31 self-acting control valve with cast iron body.