



Cert. No. LRQ 0963008

ISO 9001

spirax sarco

TI-P067-01
ST Issue 5

600 Series Steel

Inverted Bucket Steam Traps

Description

The Spirax Sarco 600 Series inverted bucket steam traps are designed for installation in vertical pipework between flanges. With forged steel body and cover they are suitable for a wide range of pressures and incorporate an integral check valve on the inlet.

Standards

This product fully complies with the requirements of the European Pressure Equipment Directive 97/23/EC and carries the CE mark when so required.

Certification

This product is available with certification to EN 10204 3.1.

Note: All certification/inspection requirements must be stated at the time of order placement.

Sizes and pipe connections

DN15 - 621, **DN20** - 622, **DN25** - 623, **DN40** - 625 and **DN50** - 626
In all sizes the body and cover forgings form the inlet and outlet flanges.

The drilled holes in both inlet and outlet flanges are tapped to receive bolts. ANSI flanges are tapped UNC. EN 1092 flanges are tapped metric.

Flanges meet the requirements of ANSI 150, ANSI 300 and ANSI 600, EN 1092 PN25 and PN40.

Pressure/temperature limits

Note: Maximum operating conditions depend on the orifice size.

Body design conditions exceed PN40

PMO - Maximum operating pressure 41 bar g @ 250°C

TMO - Maximum operating temperature 400°C @ 29 bar g

Designed for a maximum cold hydraulic test pressure of 62 bar g

Note: ANSI 300 and ANSI 600 flanges must be used only below body design conditions.

ΔPMX - Maximum differential pressure

Size	ΔPMX - Maximum differential pressure bar			
	8.5	17	31	41
DN15	621/12	621/10	621/8	621/7
DN20	622/12	622/10	622/8	622/7
DN25	623/16	623/12	623/10	623/8
DN40	625/22	625/18	625/14	625/12
DN50	626/32	626/24	626/20	626/18

Note: The pressure limit on the flange specified should be greater than the pressure limit of the internal mechanism. The table below offers guidance:

Flange	Pressure (at saturation)	Mechanism available
ANSI 150	13.8 bar g	8.5 bar
ANSI 300	42.0 bar g	all versions
ANSI 600	84.0 bar g	all versions
PN25	25.0 bar g	8.5, 17 bar
PN40	40.0 bar g	8.5, 17, 31 bar

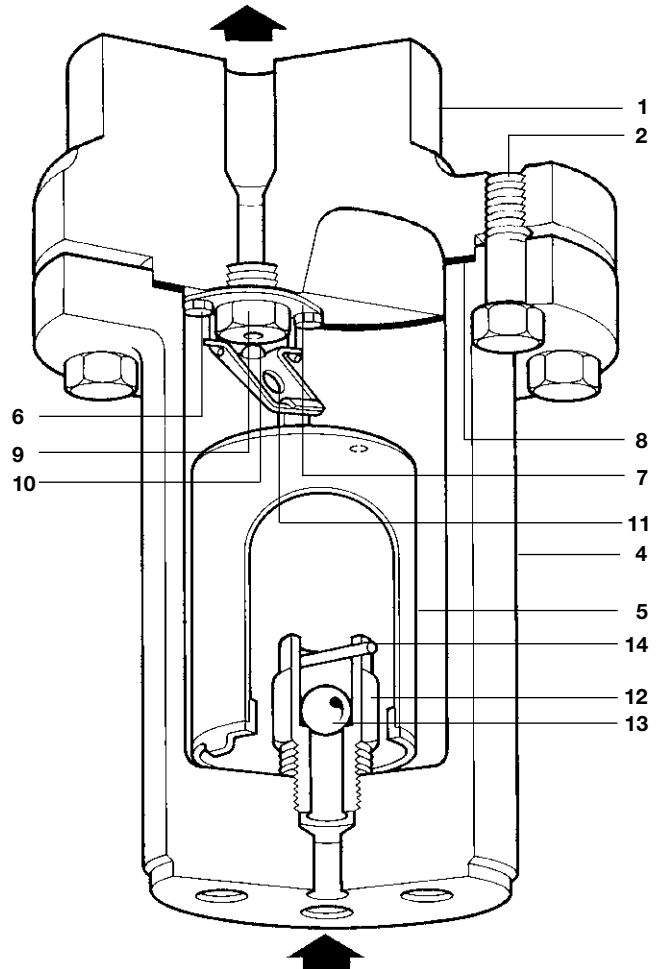

Materials

No. Part	Material	
1 Cover	Forged steel	ASTM A182 F11
2 Cover bolts	Steel	ASTM A193 Gr. B7
4 Body	Forged steel	ASTM A182 F11
5 Bucket	Stainless steel	BS 1449 304 S16
6 Valve guide plate bolts	Stainless steel	BS 4183 (18/8)
7 Valve guide plate	Stainless steel	BS 1449 304 S11
8 Cover gasket	Stainless steel reinforced exfoliated graphite	
9 Valve seat	Stainless steel	AISI 440B
10 Valve	Stainless steel	AISI 440B
11 Valve lever	Stainless steel	BS 1449 321 S31
12 Internal tube and CV seat	Stainless steel	1.4034
13 Ball valve	Stainless steel	AISI 440B
14 Retainer pin	Stainless steel	BS 1449 304

Capacities

Note: Traps should be selected for the most appropriate working pressure differential and not on the basis of load.

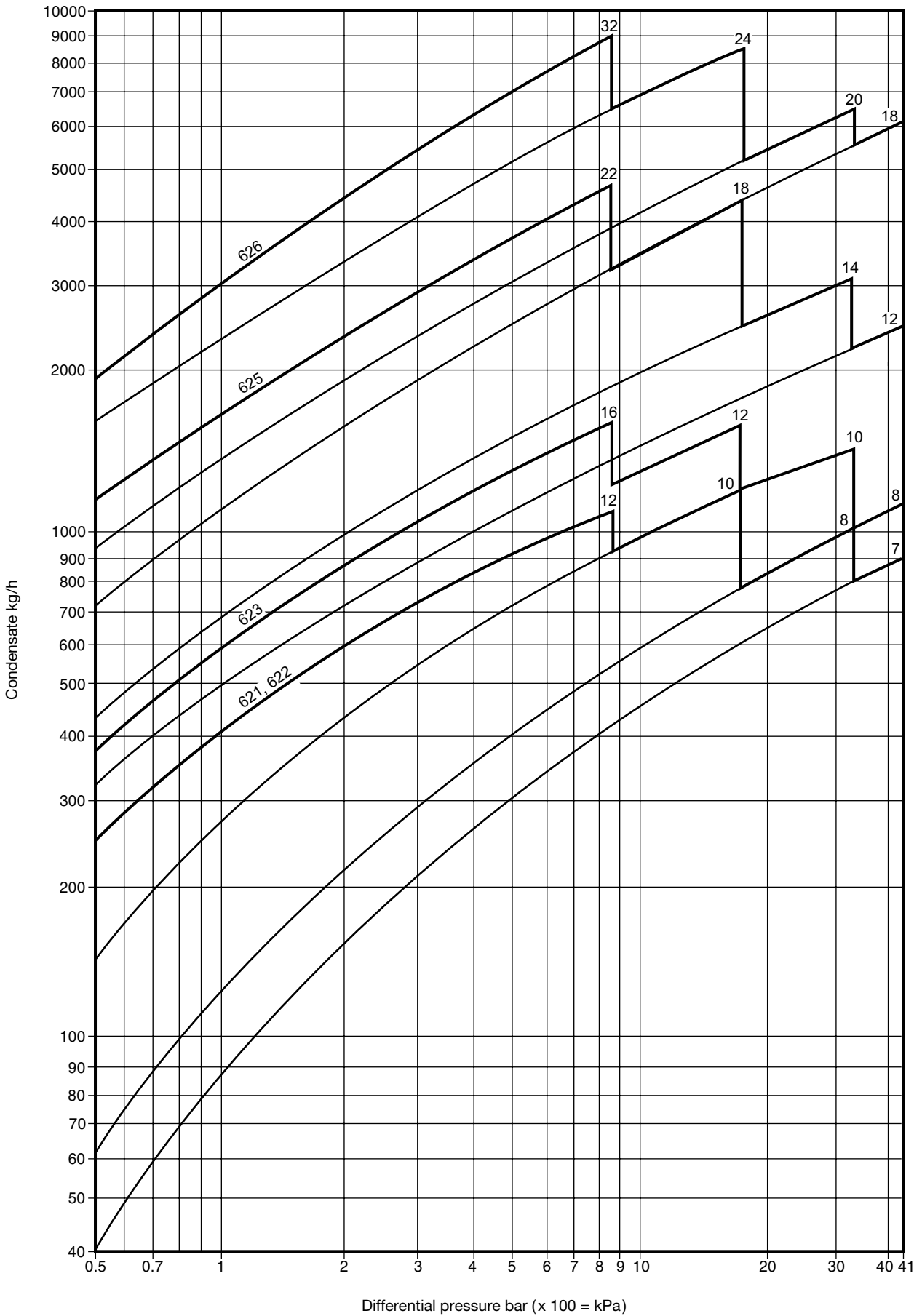

Dimensions/weights (approximate) in mm and kg

Size	A	B	C	D	E	Weight
DN15	270	185	203	121	28	18.1
DN20	270	185	203	121	28	18.1
DN25	310	203	229	130	36	29.5
DN40	410	248	305	168	45	50.0
DN50	452	301	330	213	52	79.4

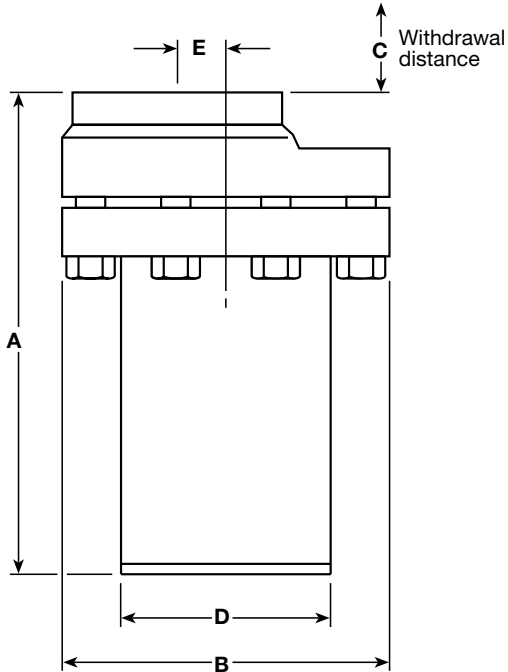

Spare parts

The spare parts available are shown in heavy outline. Parts drawn in broken line are not supplied as spares.

Available spares

Valve and seat assembly (state pressure range)	6 (2 off), 7, 9, 10, 11
Bucket	5
Check valve assembly	12, 13, 14
Cover gasket (packet of 3)	8

How to order spares

Always order spares by using the description given in the column headed 'Available spares' and state the size and full definition of the trap e.g. 622/10.

Example: 1 - Valve and seat assembly for a DN20 Spirax Sarco inverted bucket steam trap, series 622/10.

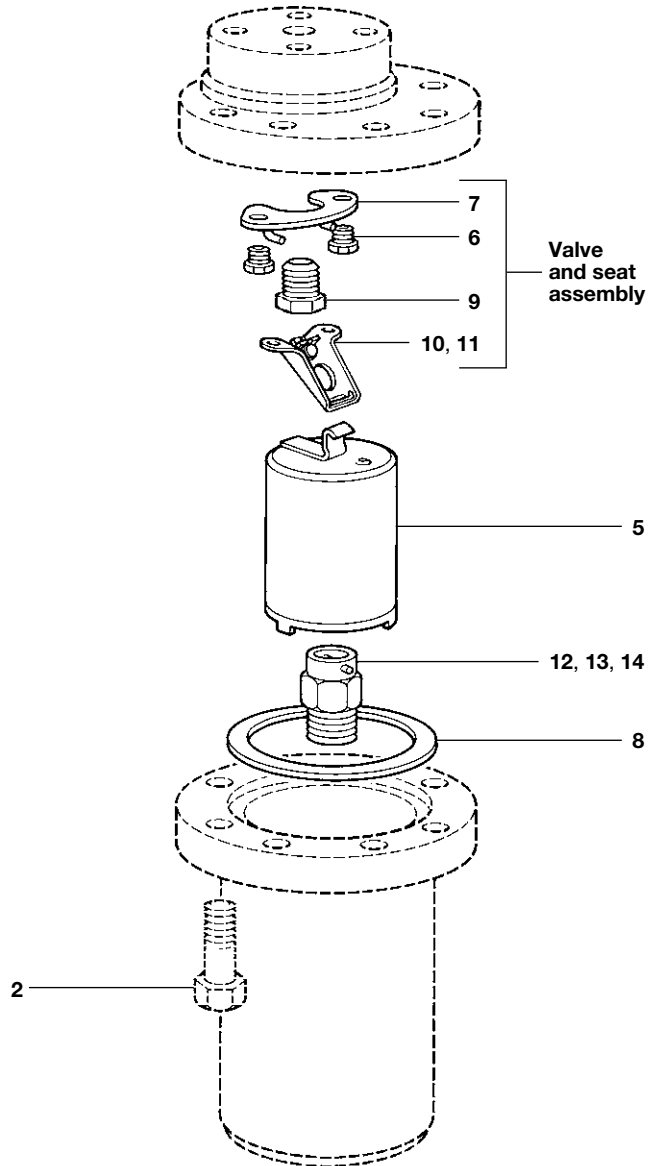

Safety information, installation and maintenance

For full details see the Installation and Maintenance Instructions (IM-P067-06) supplied with the product.

Installation note:

The trap must be installed with the body upright so that the bucket is rising and falling vertically. The inlet should be at the bottom with the trap installed below the drain point so that a water seal can be maintained around the open end of the bucket.



Disposal

This product is recyclable. No ecological hazard is anticipated with the disposal of this product providing due care is taken.

How to order

Example: 1 off Spirax Sarco DN15, 621/7 inverted bucket steam trap with steel body having flanged ANSI 600 connections.

Recommended tightening torques

Item		or		N m
		mm		
2 (621/622) (623/625) (626)		M16 x 2.0P x 45 M20 x 2.5P x 65 M22 x 2.5P x 70		75 - 80 120 - 135 150 - 165
6 (621 - 625) (626)	10 A/F 13 A/F	1/4" whit. x 1/2" 5/16" whit. x 1/2"		15 - 20 20 - 25
9 (621/622) (623/625) (626)	7/8" A/F 1 1/4" A/F 1 1/2" A/F	7/8" x 14 UNF 1 1/4" x 12 UNF 1 1/2" x 12 UNF		80 - 88 180 - 200 270 - 300
12 (621 - 623) (625/626)	1 1/8" A/F 2" A/F			200 - 220 300 - 320