



Cert. No. LRQ 0963008

ISO 9001

# spirax sarco

## CS10

**TI-P023-59**  
 ST Issue 3

## Stainless Steel Clean Steam Separator

### Description

Even in the cleanest and best designed clean steam system entrained moisture can still occur, resulting in an unacceptably low dryness fraction, non-compliance of critical sterilisation standards, damage to control valves/instrumentation and a generally low efficiency of the system.

The CS10 clean steam separator has been designed in full accordance with the ASME BPE guide (2005 edition) to overcome the issues of removing entrained moisture from clean and pure steam systems.

### Available types

**CS10-1** Has an internal surface finish of 0.5  $\mu\text{m}$  Ra and all welds are passivated and polished.

**CS10-2** Has an internal surface finish of 0.75  $\mu\text{m}$  Ra and all welds are passivated but left as laid.

**Note:** Both options have been designed with the feature of a removable baffle plate, allowing the unit to be fully inspected prior to installation and to ease periodic cleaning and de-rouging.

### Standard surface finish

Model	CS10-1	CS10-2
<b>Internal</b>	0.5 $\mu\text{m}$ (20 micro-inch) Ra maximum/SFV1 - as outlined in ASME BPE, with all welds ground and polished.	0.75 $\mu\text{m}$ (30 micro-inch) Ra maximum/SFV3 - as outlined in ASME BPE, with all welds left as laid.
<b>External</b>	1.6 $\mu\text{m}$ (63 micro-inch) Ra maximum, with a satin bead blast finish.	

### Optional surface finish (CS10-1 only)

**Internal** Polish to 0.5  $\mu\text{m}$  Ra maximum + Electropolished.

### Standards

This product has been designed in accordance with the ASME BPE guide (2005 edition).

It also complies with the requirements of the European Pressure Equipment Directive 97/23/EC.

All polymers used comply with FDA regulation CFR 21 part 177 section 2600.

1/2", 3/4" and 1" sizes are available with USP class VI.

### Certification

This product is available with the following certification:

- EN 10204 3.1 material certifications.
- Certificates of conformities.
- Passivation certificates.
- Welding certificates.
- Internal surface finish certificate.

**Note:** All certification/inspection requirements must be stated at the time of order placement.

### Packaging

Packaging for this product is conducted in a clean environment, segregated from other non stainless steel products, and in accordance with ASME BPE for optimum protection and cleanliness; Connections of the product are fitted with protective caps before being sealed in a plastic bag.

### Sizes and pipe connections

<b>Steam inlet and outlet pipe</b>	1/2", 3/4", 1", 1 1/2" and 2" Sanitary clamp ASME BPE (Tri-clamp®) or DIN 32676 upon request. Extended tube weld ends (ETO) ASME BPE or DIN 11850 upon request.
<b>Drain</b>	1" ASME BPE (Tri-clamp®)
<b>Vent</b>	1/2" ASME BPE (Tri-clamp®)

**Note:** Other connections are available upon request.

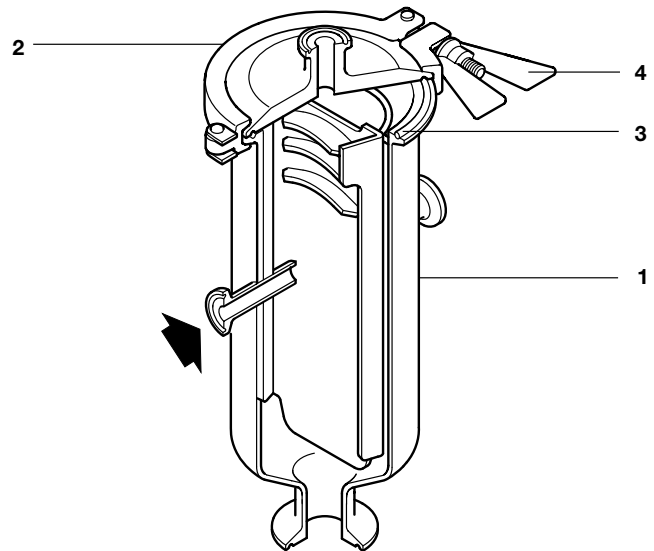

### Materials

No.	Part	Material	
1	Body	Fabricated stainless steel	ASTM A312 316L
			ASTM A240 316L
			ASTM A276 316L
2	Cover + Baffle	Fabricated stainless steel	ASTM A240 316L
			ASTM A276 316L
3	Seal	Viton	
4	Clamp	Stainless steel	AISI 316

### Pressure/temperature limits (ISO 6552)

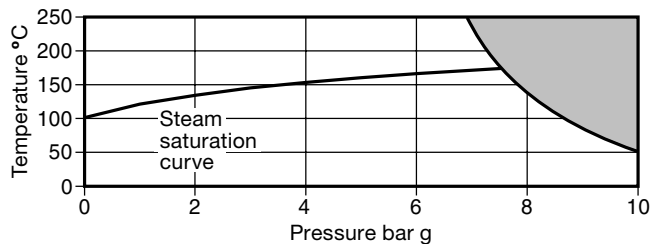

**The product must not be used in this region.**

**Note:** For hygienic/sanitary clamp ends the maximum pressure / temperature may be restricted by the gasket or sanitary clamp used. Please consult Spirax Sarco.

Body design conditions		PN10
PMA	Maximum allowable pressure	10 bar g @ 50°C
TMA	Maximum allowable temperature	250°C
Minimum allowable temperature		-10°C
PMO	Maximum operating pressure for saturated steam service	7.6 bar g
TMO	Maximum operating temperature	250°C @ 6.8 bar g
Minimum operating temperature		0°C
Designed for a maximum cold hydraulic test pressure of 15 bar g		

Local regulations may restrict the use of this product to below the conditions quoted.

In the interests of development and improvement of the product, we reserve the right to change the specification without notice.

© Copyright 2007

### Steam sizing example

The steam sizing example below has been based on imperial O/D tubing delivering 500 kg/h of steam at 6 bar g.

- Plot point A** where the steam pressure and flowrate cross, e.g. 6 bar g @ 500 kg/h: Draw a horizontal line.
- Select line size.** Any separator curve that is bisected by this line at a velocity **below 27 m/s** will operate at near 100% efficiency. For this example choose a 2" (DN50) separator, point **B**.
- Ascertain velocity.** Line velocity for any size can be determined by drawing a vertical line upwards from the point of intersection. From point **B** in this example the line crosses the velocity axis at 15 m/s.  
**Note:** a velocity correction factor needs to be applied - Please refer to the correction factor table below. For this example the velocity correction factor is 1.22 for a 2" imperial O/D tube therefore the velocity in this example would be 18.3 m/s.
- Pressure drop.** Where the line extended from point **B** crosses the line **C - C**, plot a horizontal line. Now drop a vertical line from point **A**. The point of intersection, **D**, is the pressure drop across the separator, i.e. approximately 0.012 bar.
- Separators should be selected on the basis of the best compromise between line size, velocity and pressure drop for each application.**

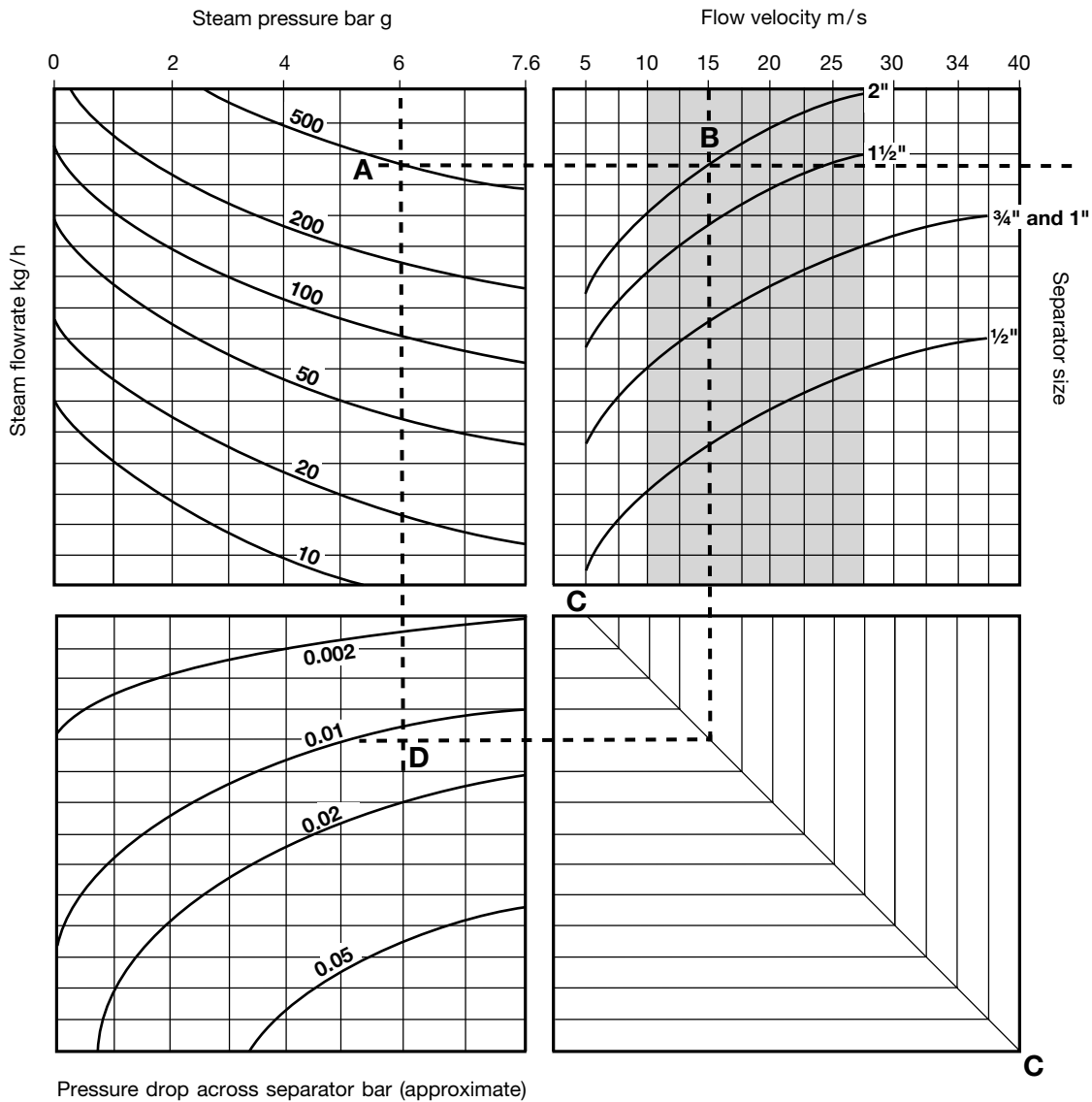

### Velocity correction factor table

Separator size		1/2"	3/4"	1"	1 1/2"	2"
Schedule 40 pipe	I/D (mm)	15.80	21.00	26.60	40.90	52.50
	Factor	1.00	1.00	1.00	1.00	1.00
Imperial O/D tubing	I/D (mm)	9.40	15.75	22.10	34.80	47.50
	Factor	2.83	1.45	1.45	1.38	1.22
Hybrid DIN 11850 pipe	I/D (mm)	15.00	19.00	25.00	37.00	49.00
	Factor	1.11	1.13	1.13	1.22	1.15

**Dimensions, weights and volume** (approximate) mm, kg and litres

Steam inlet/ outlet size	A	B	C	D	F (drain)	G (vent)	H	J	Weights	Volume
½"	135	161	290	88.9	1"	½"	23	215	3.0	1.2
¾"	160	178	371	114.3	1"	½"	23	290	5.0	2.5
1"	160	178	371	114.3	1"	½"	23	290	5.0	2.5
1½"	195	213	485	141.3	1"	½"	27	400	9.2	5.5
2"	195	213	535	141.3	1"	½"	27	450	10.0	6.3

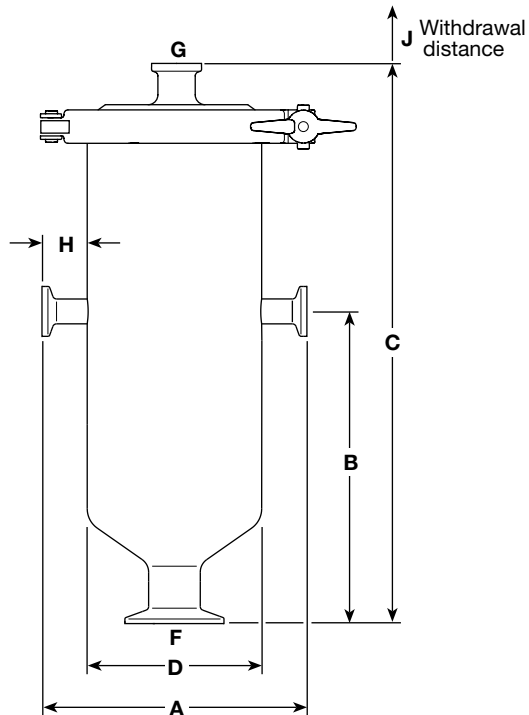
**Safety information, installation and maintenance**

For full details see the Installation and Maintenance Instructions (IM-P023-60) supplied with the product.

**Installation note**

The CS10 is designed for installation in horizontal lines. Check arrow for correct orientation.

**Note:** The body and internals must be handled carefully to ensure that the surface finishes are not damaged.

**How to order**

**Example:** 1 off 2" Spirax Sarco CS10-1 stainless steel clean steam separator with removable baffle plate. Sanitary clamp connections to ASME BPE, internal surface finish of 0.5 µm complete with material certification to EN 10204 3.1.

**Spare parts**

Please refer to the dimension drawing to the left.

**Available spares**

Seal	<b>3</b>
Clamp	<b>4</b>

**How to order spares**

Always order spares by using the description given in the column headed 'Available spares' and state the size and type of separator.

**Example:** 1 off Seal for a Spirax Sarco 1½" CS10-1 stainless steel clean steam separator.