



spirax sarco

IBPS32

TI-P005-05
ST Issue 4

Cert. No. LRQ 0963008

ISO 9001

Stainless Steel Balanced Pressure

Thermostatic Steam Trap with Integral Spiratec Sensor

Description

The IBPS32 is a stainless steel maintainable balanced pressure thermostatic steam trap fitted with an integral Spiratec sensor and straight connections. It also has an integral 'Y' type strainer. It can be supplied with a sensor to detect waterlogging and steam leakage (WLS1) or for steam leakage only (SS1). The IBPS32 can be easily integrated into all existing Spiratec monitoring systems.

All pressure bearing components are produced by TÜV approved suppliers in accordance with AD-Merkblatt WO/TRD100.

Standard unit IBPS32 having 'STD' fill capsule

Also available IBPS32CV having 'STD' fill capsule and check valve

Note: When placing an order always state capsule fill.

Capsule fill and operation:

Standard capsule - Is marked with 'STD' for operation at approximately 12°C below steam saturation temperature.

Optionally - The capsule can be supplied for sub-cooled 'SUB' operation at approximately 24°C below steam saturation temperature or near-to-steam 'NTS' operation at approximately 6°C below steam temperature.

Standards

This product fully complies with the requirements of the European Pressure Equipment Directive 97/23/EC.

Certification

This product is available with certification to EN 10204 3.1

Note: All certification/inspection requirements must be stated at the time of order placement.

Sizes and pipe connections

½", ¾", and 1" screwed BSP or NPT.

½", ¾", and 1" socket weld ends to BS 3799.

½", ¾", and 1" butt weld ends to EN 12 627.

DN15, DN20 and DN25 standard flange to EN 1092 PN40, ANSI B 16.5 Class 150 and 300, JIS/KS 10K and JIS/KS 20K.

Pressure/temperature limits (ISO 6552)

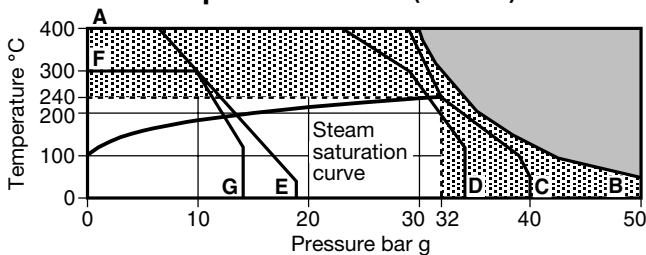

A The product **must not** be used in this region.

B-G The product should not be used in this region or beyond its operating range as damage to the internals may occur.

- A - B Screwed, socket weld, butt weld and flanged ANSI 300.
- A - C Flanged EN 1092 PN40.
- A - D Flanged JIS/KS 20K.
- A - E Flanged ANSI 150.
- F - G Flanged JIS/KS 10K.

Maximum body design conditions		PN40
PMA	Maximum allowable pressure	50 bar g @ 50°C
TMA	Maximum allowable temperature	400°C @ 30 bar g
Minimum allowable temperature		-200°C
PMO		Maximum operating pressure for saturated steam service
		32 bar g
TMO		Maximum operating temperature
		240°C @ 32 bar g
Minimum operating temperature		0°C

Note: For lower operating temperatures consult Spirax Sarco
Designed for a maximum cold hydraulic test pressure of 75 bar g

IBPS32

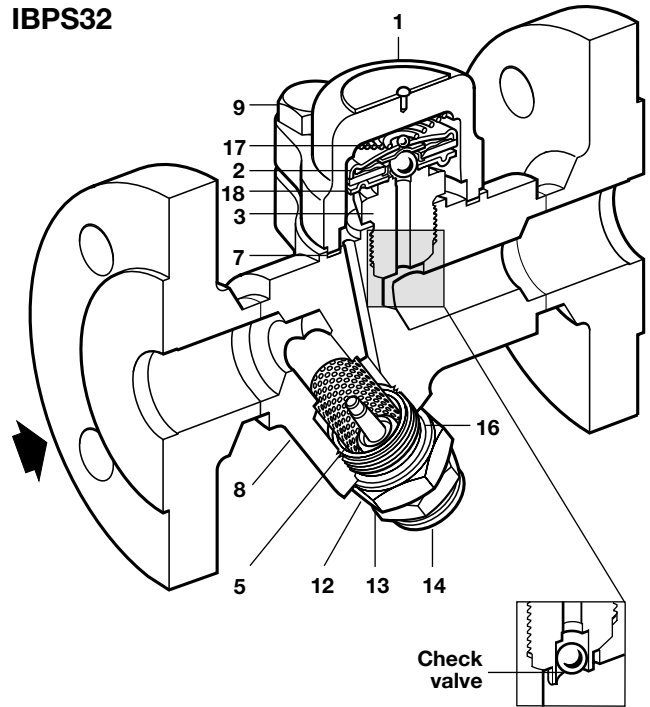

IBPS32CV

Materials

No.	Part	Material	
1	Cover	Austenitic stainless steel	DIN 17440 (W/S 1.4571) 316 Ti
2	Capsule	Stainless steel	
3	Valve seat	Stainless steel	BS 970 431 S29
5	Strainer screen	Stainless steel	AISI 304
7	Cover gasket	Stainless steel reinforced exfoliated graphite	
8	Body/flanges	Austenitic stainless steel	DIN 17440 (W/S 1.4571) 316 Ti
9	Cover bolts	Stainless steel (M10 x 30)	A2-70
12	Sensor adaptor	Stainless steel	DIN 17440 (W/S 1.4404) 316L
13	Sensor gasket	Stainless steel	BS 1449 304 S16
14	Sensor	Stainless steel	BS 1449 304 S16
15	Blanking plug (not shown)	Stainless steel	
16	Adaptor gasket	Stainless steel	BS 1449 304 S16
17	Spring	Stainless steel	
18	Spacer plate	Stainless steel	

Local regulations may restrict the use of this product to below the conditions quoted.

In the interests of development and improvement of the product, we reserve the right to change the specification without notice.

© Copyright 2007

Dimensions/weights (approximate) in mm and kg

Size	A	A1	B	C	E	F	G	Weight	
								Scrd/SW/BW/Flgd	
½" DN15	95	150	94	64	37	63	28	1.65	3.15
¾" DN20	95	150	94	64	37	64	28	1.65	3.75
1" DN25	95	160	94	64	37	66	28	1.85	4.45

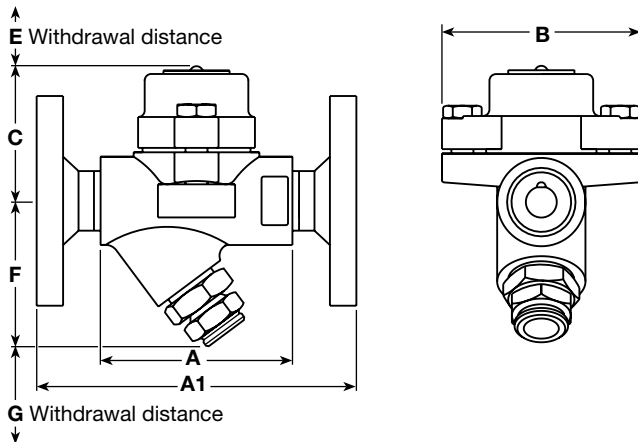

Capacities

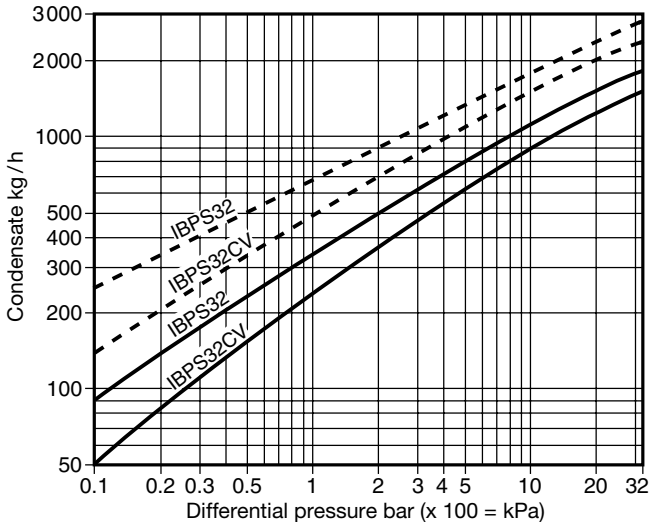

Hot water capacity ——— Cold water capacity - - - - -

Safety information, installation and maintenance

For full details see the Installation and Maintenance Instructions (IM-F01-30) supplied with the product.

Installation note:

The IBPS32 is designed for installation with the capsule in a horizontal plane with the cover at the top.

It is recommended that a non-return valve is fitted when discharging condensate into return lines where backpressure is experienced. It is also recommended that a diffuser is fitted when discharging to atmosphere.

For ease and maintenance, consideration should be given to fitting isolation valves upstream and downstream of the steam trap.

Disposal

The product is recyclable. No ecological hazard is anticipated with the disposal of this product, providing due care is taken.

How to order

Example: 1 off Spirax Sarco ½" IBPS32 stainless steel bodied maintainable balanced pressure thermostatic steam trap. Screwed BSP with 'STD' fill capsule for operation at approximately 12°C below steam saturation temperature.

The trap will be supplied with an integral sensor to identify waterlogging and steam wastage (WLS1 sensor) or for steam leakage only (SS1 sensor). Sensors to be compatible with Spiratec indicators, automatic monitors and test points:

R1 (single trap) remote test point, R12 (12 trap) remote test point, Type 30 hand held indicator, R16C (16 traps) automatic steam trap monitor or R1C (single trap) automatic steam trap monitor with PNP/NPN output where appropriate.

Spare parts

The spare parts available are shown in heavy outline. Parts drawn in broken line are not supplied as spares.

Available spares

Capsule and seat assembly set	2, 3, 17, 18
Strainer screen Y-type cylindrical (1 off)	5
Set of cover gaskets (packet of 3)	7
Sensor and sensor gasket	13, 14
Adaptor gasket (packet of 3)	16

How to order spares

Always order spares by using the description given in the column headed 'Available spares' and state the size, model number and capsule reference.

Example: 1 - Capsule and seat assembly set for a Spirax Sarco DN25 IBPS32 having 'STD' fill capsule for operation at 12°C below steam saturation temperature with integral Spiratec sensor.

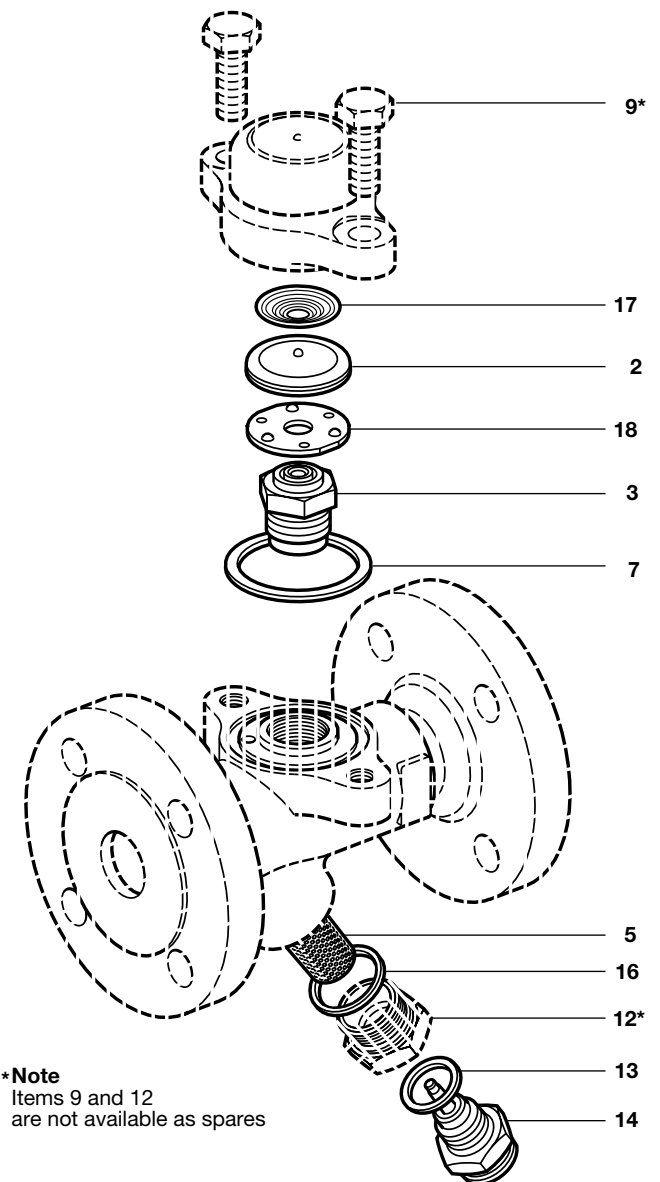

*Note
Items 9 and 12
are not available as spares

Recommended tightening torques

Item	Part	mm		N m
		or		
3	Valve seat	24 A/F		115 - 125
9	Cover bolts	16 A/F	M10 x 30	23 - 27
12	Sensor adaptor	27 A/F		120 - 135
14	Sensor	24 A/F		50 - 56