



Cert. No. LRQ 0963008

ISO 9001

spirax sarco

TI-P001-07
CH Issue 4

LRV2B and LRV2S Gunmetal Pressure Reducing Valves

Description

The LRV2B and LRV2S are direct acting pressure reducing valves suitable for liquid applications.

Available types

LRV2B Phosphor bronze/brass bellows

LRV2S Stainless steel (316 Ti/316L) bellows

LRV2B and LRV2S pressure reducing valves are supplied with one of three colour coded springs which are identified by the disc (19) located on the adjustment handwheel:

Grey For downstream pressure control: 0.35 to 1.7 bar g

Green For downstream pressure control: 1.40 to 4.0 bar g

Orange For downstream pressure control: 3.50 to 8.6 bar g

Note: where control spring ranges overlap always use the lower range to give better control.

Sizes and pipe connections

½", ¾", 1" Screwed BSP (BS 21 Rp) or NPT.

Pressure/temperature limits

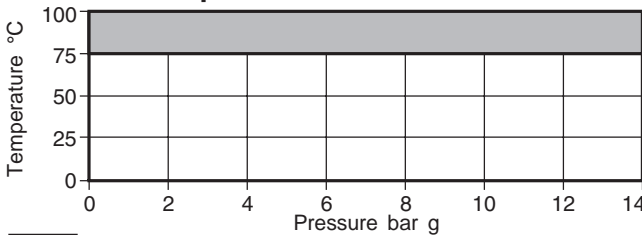

This product **must not** be used in this region.

| | |
|--|-----------------|
| Body design conditions | PN25 |
| PMA Maximum allowable pressure @ 120°C | 25 bar g |
| TMA Maximum allowable temperature @ 17 bar g | 100°C |
| Minimum allowable temperature | 0°C |
| PMO Maximum operating pressure | 14 bar g @ 75°C |
| TMO Maximum operating temperature | 75°C @ 14 bar g |
| Minimum operating temperature | 0°C |

Note: For lower operating temperatures consult Spirax Sarco.

ΔPMX Maximum differential pressure is limited to the PMO

Maximum recommended turndown ratio 10:1 at maximum flow

Designed for a maximum cold hydraulic test pressure of 38 bar g

Note: With internals fitted, test pressure must not exceed 17 bar g

Materials

| No. Part | Materials |
|------------------------------|--|
| 1 Spring housing | Aluminium epoxy coated LM 24 |
| 2 Adjustment handwheel | Polypropylene |
| 3 Top spring plate | Cast iron DIN 1691 GG 20 |
| 4 Pressure adjustment spring | Silicon chrome BS 2803 685 A55 spring steel Range 2 |
| 5 Bellows assembly | Stainless steel 316Ti/316L Phosphor bronze BS 2872 CZ 122 |
| 6 Bellows assembly gasket | Stainless steel reinforced exfoliated graphite |
| 7 Hex. bolt (M8 x 25 mm) | Steel zinc plated BS 3692 Gr. 8.8 |
| 8 Body | Gunmetal BS 1400 LG2 |
| 9 Cone shaped washer | Stainless steel ASTM A276 316L |

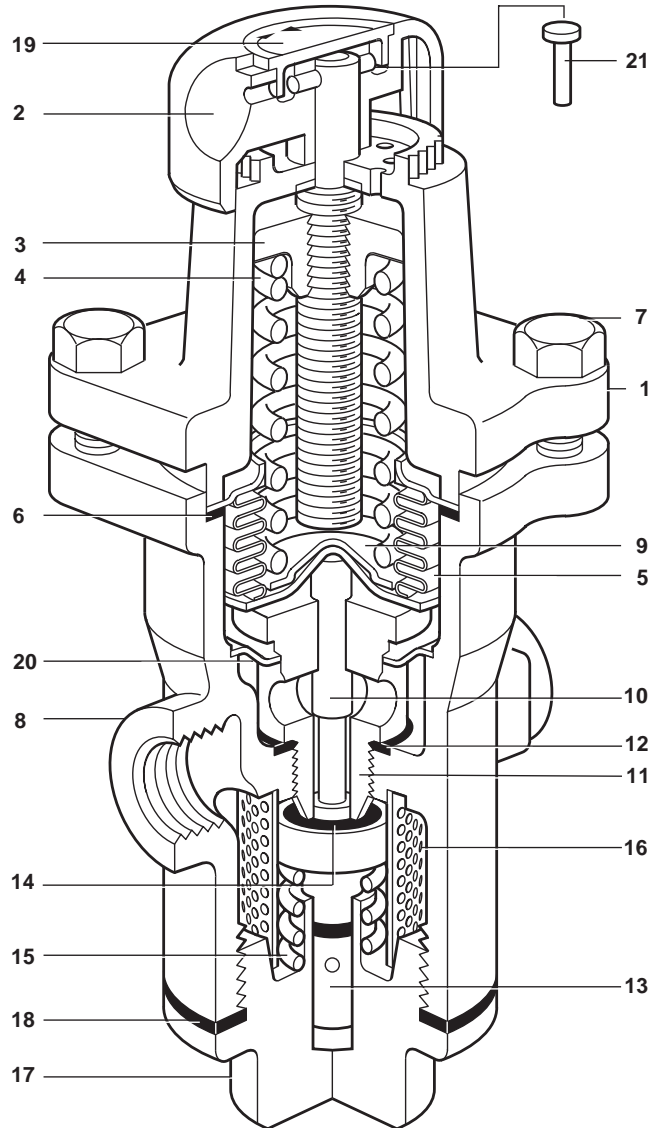

| No. Part | Materials |
|-------------------------|--|
| 10 Push rod | Stainless steel ASTM A276 316L |
| 11 Valve seat | Stainless steel BS 970 431 S29 |
| 12 Valve seat gasket | Stainless steel BS 1449 316 S11 |
| 13 Piston | Stainless steel BS 970 431 S29 |
| 14 Valve head | Nitrile rubber |
| 15 Piston return spring | Stainless steel BS 2056 Gr. 302 S26 |
| 16 Strainer screen | Stainless steel BS 1449 316 S16 |
| 17 Cap | Brass BS 2872 CZ 122 |
| 18 Cap gasket | Stainless steel reinforced exfoliated graphite |
| 19 Spring range ID disc | Polypropylene |
| 20 Bulkhead plate | Stainless steel 316L |
| 21 Tamper-proof pin | Mild steel copper plated |

Local regulations may restrict the use of this product to below the conditions quoted.

In the interests of development and improvement of the product, we reserve the right to change the specification.

© Copyright 2004

Capacities

Full lift capacity for safety valve sizing purposes are shown below:

| Size | 1/2" | 3/4" | 1" |
|------|------|------|-----|
| Kvs | 2.1 | 3.6 | 4.3 |

For conversion: C_V (UK) = $K_V \times 0.963$ C_V (US) = $K_V \times 1.156$

Dimensions / weight (approximate) in mm and kg

| Size | A | B | C | D | E | F | Weight |
|------|-----|----|----|-----|----|----|--------|
| 1/2" | 83 | 32 | 62 | 130 | 25 | 40 | 2.0 |
| 3/4" | 96 | 32 | 62 | 130 | 25 | 40 | 2.1 |
| 1" | 108 | 32 | 62 | 130 | 25 | 40 | 2.4 |

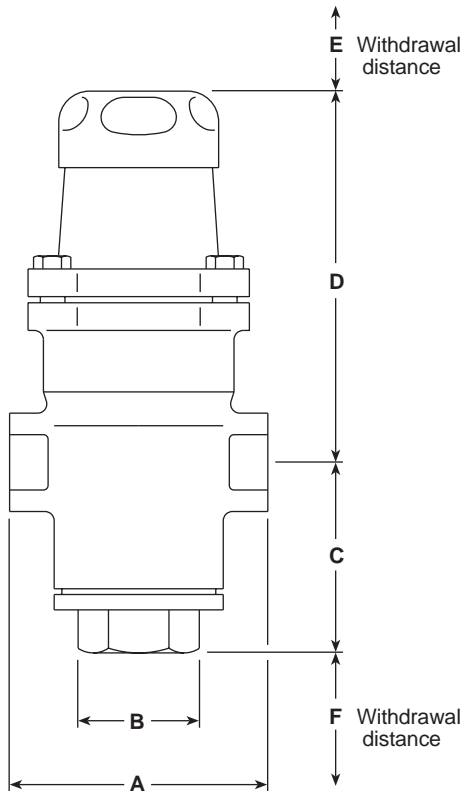

Safety information, installation and maintenance

For full details see the Installation and Maintenance Instructions (IM-P001-08) supplied with the product.

Installation note:

The valve should be installed in a horizontal pipeline with the direction of flow as indicated by the arrow on the valve body.

How to order

Example: 1 off Spirax Sarco 1/2" LRV2S pressure reducing valve with gunmetal body, screwed BSP connections, stainless steel bellows and fitted with an orange spring for downstream pressure control of 3.5 to 8.6 bar g.

Spare parts

The spare parts available are shown in heavy outline. Parts drawn in broken line are not supplied as spares.

Available spares

| | | | |
|--|------------------------------------|-------------------|--------------------------------------|
| * Pressure adjustment spring | Grey | 0.35 to 1.7 bar g | 4, 19 |
| | Green | 1.40 to 4.0 bar g | 4, 19 |
| | Orange | 3.50 to 8.6 bar g | 4, 19 |
| * Bellows assembly specify type | Stainless steel or phosphor bronze | | 5, 6, 9 |
| * Spring housing hex. bolts (set of 4) | | | 7 |
| Valve and seat assembly | | | 6, 11, 12, 13, 14, 15, 16, 20 |
| * Gasket set | | | 6, 12, 18 |
| * Strainer screen | | | 16 |



How to order spares

Always order spares by using the description given in the column headed 'Available spares' and state the size, type and pressure range of the reducing valve.

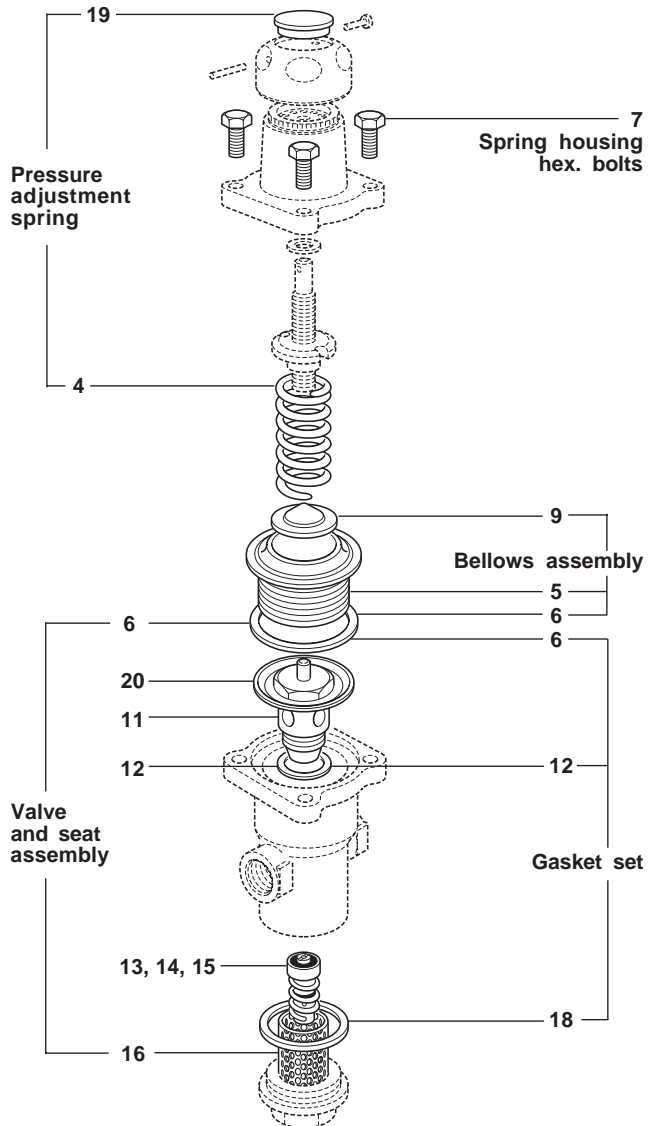
Example: 1 off Pressure adjustment spring (orange), having a downstream pressure range of 3.5 to 8.6 bar g for a Spirax Sarco 1/2" LRV2S pressure reducing valve.



Recommended tightening torques

| Item no. | Part |  or  | mm | N m |
|----------|------------|--|---------|-----------|
| 7 | Hex. bolts | 13 A/F | M8 x 25 | 13 - 15 |
| 11 | Valve seat | 32 A/F | | 108 - 132 |
| 16 | Bottom cap | 32 A/F | | 65 - 75 |