



Cert. No. LRQ 0963008

ISO 9001

spirax sarco

CE43

TI-F12-21
CH Issue 4

1" (DN25) to 4" (DN100)

Carbon Steel Cage Design, Two-Port Control Valves

Description

The CE43 series is a range of carbon steel two-port, cage trim, control valves conforming to ASME B 16.34, ASME VIII standards in sizes 1" to 4" (DN25 to DN100) available with ASME and PN flange connections. When used in conjunction with a pneumatic linear actuator 'C' series valves will provide characterised modulating or on/off control.

Compatible actuators and positioners:

Pneumatic actuators	PN1000 series, spring-to-close
	PN2000 series, spring-to-open
Positioners	PP5 (pneumatic)
	EP5 (electropneumatic)
	SP2 (smart electropneumatic)

Refer to the relevant Technical Information Sheet for further details.

Sizes and pipe connections

1", 1½", 2", 2½", 3" and 4" (DN25, DN40, DN50, DN65, DN80 and DN100) Flanged to ASME (ANSI) 150, 300 or 600 (Raised face or ring type joint), PN16, PN25, PN40, PN63 and PN100 (Raised face with ASME (ANSI) face-to-face dimension). 1", 1½" and 2" socket weld..

Options

Trim	Equal %, linear, fast opening (on/off) characteristics, soft seat, hard faced, low noise and anti-cavitation (single and multi-cage).
Stem seal	PTFE chevron, graphite packing and bellows.
Plug	Balanced or unbalanced to: ASME (ANSI) Class IV, V or VI shut-off.

See 'C' series valve options Technical Information Sheet TI-F12-23.

Technical data

Plug design	Unbalanced plug	
	PTFE sealed balanced plug	
Trim design	Graphite sealed balanced plug	
	Cage trim with equal percentage, linear and fast opening flow characteristic options.	
Leakage	Class IV	Metal-to-metal seat IEC 534-4
	Class IV & V	Hard face stellite IEC 534-4
	Class VI	PTFE soft seat IEC 534-4
Flow characteristic	CE valves	Equal percentage
	CF valves	Fast opening
	CL valves	Linear
	CM valves	Modified characteristic (special)
Rangeability	50:1 Equal percentage	
	30:1 Linear	
Travel	1" and 1½"	(DN25 and DN40) ¾" (20 mm)
	2"	(DN50) 1⅞" (30 mm)
	2½" and 3"	(DN65 and DN80) 1½" (38 mm)
	4"	(DN100) 2" (50 mm)

Limiting conditions

Body design conditions	ASME (ANSI) 600		
Design temperature	Standard PTFE chevron stem seals	14°F to +482°F	(-10°C to +250°C)
	Graphite packing stem seals	Standard bonnet	14°F to +572°F (-10°C to +300°C)
		Extended bonnet	14°F to +797°F (-10°C to +425°C)
	Graphite sealed balanced plug	(Class IV)	797°F (425°C)
	PTFE sealed balanced plug	(Class VI)	356°F (180°C)
Designed for a maximum cold hydraulic test pressure of:	ASME (ANSI) 600	2 220 psi g	(153 bar g)
Maximum differential pressure	See relevant actuator TI		

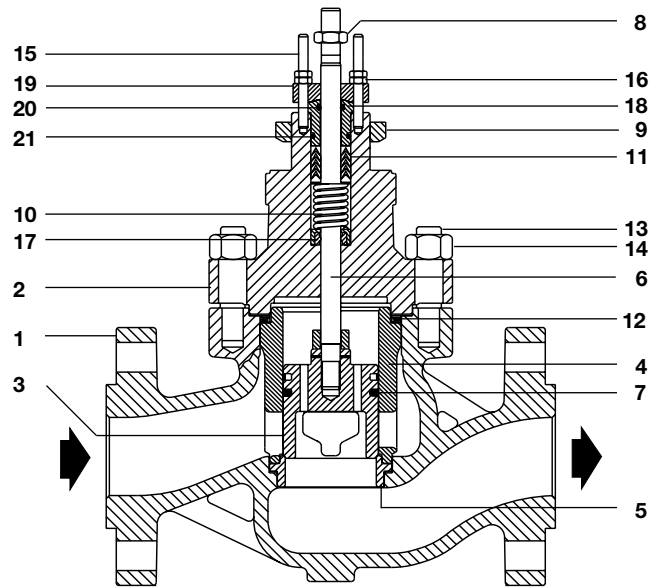

Materials

No.	Part	Material	
1	Body	Carbon steel	ASTM A216 WCB
2	Bonnet	Carbon steel	ASTM A216 WCB
3	Valve plug	Stainless steel	AISI 431 hardened
4	Valve cage	Stainless steel	AISI 316 ENC
5	Valve seat	Stainless steel	AISI 431
6	Valve stem	Stainless steel	AISI 316
7	Valve plug sealing rings	PTFE and graphite or graphite	
8	Lock-nut	Stainless steel	AISI 316
9	Mounting nut	Zinc plated carbon steel	
10	Gland spring	Stainless steel	AISI 302
11	Gland seal	PTFE chevron or graphite	
12	Bonnet gasket	Reinforced exfoliated graphite	
13	Bonnet studs	Carbon steel	ASTM A 193 B7
14	Bonnet nuts	Carbon steel	ASTM A 194 2H
15	Stuffing box studs	Carbon steel	ASTM A 193 B7
16	Stuffing box nuts	Carbon steel	ASTM A 194 2H
17	Stem scraper	Glass filled PTFE	
18	Stuffing box bush	Stainless steel	AISI 316
19	Stuffing box ring	Stainless steel	AISI 316
20	Valve stem wiper	Fluoroelastomer	
21	'O' ring	Fluoroelastomer	

Local regulations may restrict the use of this product to below the conditions quoted.

In the interests of development and improvement of the product, we reserve the right to change the specification without notice.

© Copyright 2010

Operating range for body material and flange type only.

Note: See limiting conditions for stem and plug limitations.

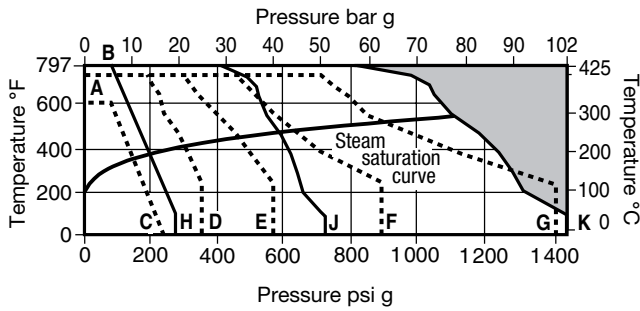

The product must not be used in this region.

A-C PN16, A-D PN25, A-E PN40, A-F PN63, A-G PN100
B-H ASME 150, B-J ASME 300, B-K ASME 600

Dimensions (approximate) in inches and (mm)

Valve size	1"	1½"	2"	2½"	3"	4"	
	DN25	DN40	DN50	DN65	DN80	DN100	
A	ASME 300 PN25 - PN40	7¾" (197)	9¼" (235)	10½" (267)	11½" (292)	12½" (317)	14½" (368)
	ASME 600 PN63 - PN100	8¼" (210)	9" (251)	11¼" (286)	12¼" (311)	13¼" (337)	15½" (394)
B	2½" (62)	3" (80)	3" (80)	3¾" (95)	4⅞" (105)	5" (128)	
C	5½" (141)	7" (179)	7 ⅞" (183)	8¼" (209)	8¼" (209)	9¾" (247)	
C1	Extended bonnet	10" (255)	11½" (293)	11 ⅜" (296)	13½" (344)	13½" (344)	15" (382)
	Bellows sealed bonnet	15" (380)	16½" (419)	18 ¼" (480)	20" (506)	20" (506)	25" (634)

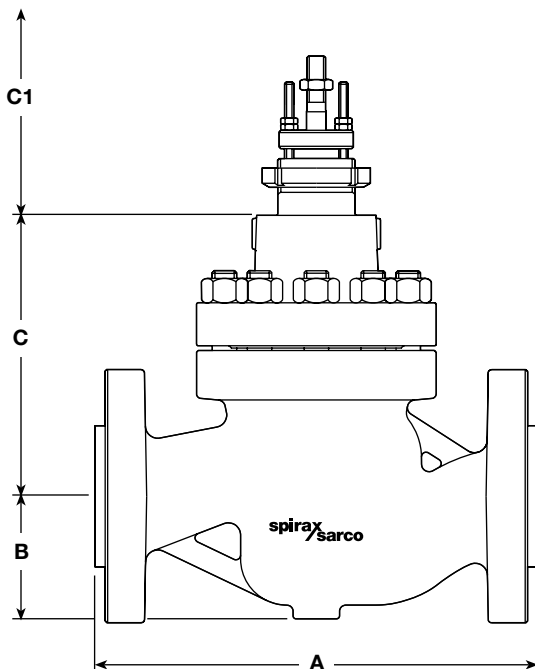

Weights (approximate) in lbs and (kg)

Valve size	1"	1½"	2"	2½"	3"	4"
	DN25	DN40	DN50	DN65	DN80	DN100
Weights	29 (13)	48 (22)	59 (27)	92 (42)	130 (59)	213 (97)

Valve flow coefficients at 100% lift

Cv (US) for single stage trims (K_{VS} shown in brackets).

Size	Equal % C _v (K _{VS})	F _L
1" (DN25)	18.00 (15.00)	0.94
1½" (DN40)	36.00 (31.00)	0.94
2" (DN50)	60.00 (51.00)	0.94
2½" (DN65)	99.00 (85.00)	0.94
3" (DN80)	136.00 (116.00)	0.90
4" (DN100)	223.00 (191.00)	0.89

Three reduced C_v are available for equal percentage and linear trims, for further details see TI-F12-23 'C' series control valve options.

For conversion C_v (UK) = C_v (US) x 0.833 K_{VS} = C_v (US) x 0.865

Sizing

Please consult Spirax Sarco.

Installation

The valve should be installed in a horizontal pipeline with the direction of flow as indicated by the arrow on the valve name-plate. The actuator position will depend on the type fitted to the valve. Full instructions are supplied with the product.

'C' series valve selection guide

Valve size	1", 1½", 2", 2½", 3" and 4" DN25, 40, 50, 65, 80 and 100	<input type="text" value="2"/>
Valve series	C = Cage trim	<input type="text" value="C"/>
Valve characteristic	L = Linear E = Equal percentage F = Fast opening M = Modified equal percentage	<input type="text" value="E"/>
Body material	4 = Carbon steel	<input type="text" value="4"/>
Connections	3 = Flanged 4 = Socket weld (1", 1½" and 2")	<input type="text" value="3"/>
Stem sealing options	P = PTFE chevron H = Graphite B = Bellows	<input type="text" value="P"/>
Seating options	T = AISI 431 hardened G = PTFE soft seat W = Hard face AISI 316	<input type="text" value="T"/>
Type of trim	C = Standard cage P = Noise reducing perforated cage A = Anti-cavitation cage	<input type="text" value="C"/>
Number of stages	1 = One 2 = Two 3 = Three Other = To be specified	<input type="text" value="1"/>
Trim balancing	B = Balanced U = Unbalanced	<input type="text" value="U"/>
Bonnet type	S = Standard H = Extended for high temperature L = Extended for low temperature	<input type="text" value="S"/>
Reduced trim	0 = No reduction 1 = 1 reduction 2 = 2 reductions 3 = 3 reductions	<input type="text" value="1"/>
C _v	To be specified	<input type="text" value="Cv 35"/>
Connection type	To be specified	<input type="text" value="ASME 300"/>

How to order

Example: 1 off Spirax Sarco 2" CE43 PTC1US1 Cv 35 control valve having flanged ASME 300 connections.

Spare parts

See TI-F12-22.