

Ball valves

an overview



spirax
/sarco

An efficient and reliable process demands quality products

Industrial plant and processes demand efficient operation. Spirax Sarco ball valves complement this need with safe and effective shut-off and a range of high performance, low cost options.

Increasingly, users want to choose from a comprehensive range which offers a choice of body design, materials, connections, seals and options, plus specialty valves which are suitable for specific applications and different process fluids. Many users also want to be able to automate the valve if required.

Spirax Sarco has a broad range which is clearly segmented to suit your application requirement and ease selection.



A modern manufacturing plant

When selecting a ball valve supplier, a major concern is the level and consistency of quality. To satisfy these needs we have invested heavily in our ball valve production process. Spirax Sarco have a modern manufacturing site totally dedicated to the design and development, manufacture and worldwide despatch of ball valves.



User benefits

- Manufactured to **stringent specification** providing reliable **tight shut-off** and **less maintenance**.
- **Wide range** of sizes, materials and body design option providing a suitable model for any application.
- Precision design providing **compact** valves.
- Quarter turn on/off ensuring **easy operation** and maintenance.
- ISO mounting models which are quick and **easy to automate**.
- **Low torque** valves with **smaller actuators** for automation.
- Unrestricted flow allowing **low pressure drop** and high capacity.
- Corrosion resistant bodies ensure **long life** of the product.
- Local stocks ensuring **fast delivery**.
- **High quality** (modern manufacturing plant) ensuring high performance at **low cost**.
- **Spirax Sarco's guarantee of worldwide knowledge, service and technical support.**

Ball valve selection matrix

Applications		3 piece	2 piece		1 piece	
		Screwed, SW, BW, flanged	ANSI flanges	DIN flanges	ANSI flanges	DIN flanges
Steam applications (see Steam Sales Brochure)	Low pressure steam (<10 bar)	M10V	M31V	M31V	M40V	M21S
	Medium pressure steam (<17.5 bar)	M10S	M31S	M31S	M40S	M21S
	High pressure steam (<39 bar)	M10H	M31H	M31H	M20H	M20H
	Clean steam	M60V M60G				
	Condensate and process water	M10V	M31V	M31V	M40V	M21S
	Boiler blowdown				M20S	M20S
Other applications (see Liquids and Gases Sales Brochure)	Slurry and dirty fluids	M15V M15K			M45V M45K	
	Teflon free	M10T	M31T	M31T	M40T	M21T
	Thermal oils (<250°C)	M10S	M31S	M31S	M40S	M21S
	Thermal oils (<315°C)	M10H M15K	M31H	M31H	M20H	M20H
	Mineral oils	M10S	M31S	M31S	M40S	M21S
	Liquid hydrocarbons (<50 bar)	M10V	M31S	M31S	M40S	M21S
	Liquid hydrocarbons (<100 bar)	M10S				
	Liquid hydrocarbons (<145 bar)	M10P				
	Edible oil (use and distribution)	M10V M10S	M31V M31S	M31V M31S	M40V M40S	M21S
	Edible oil (distillation)	M10H M15K	M31H	M31H	M45V M45K	
	Natural gas	M10V M10S	M31V M31S M32S	M31V M31S	M40V M40S M42S	M21S
	Industrial gases O ₂ , N ₂ , CO ₂ , inert gases	M10S	M31V M31S	M31V M31S	M40V M40S	M21S
	High pressure gases (<350 bar)	M10HP				
	Cooling system (Glycol)	M10V M10S	M31V M31S	M31V M31S	M40V M40S	M21S
	Compressed air	M10V M10S	M31V M31S	M31V M31S	M40V M40S	M21S
	CO ₂ liquid (>-30°C)	M10V	M31V	M31V	M40V	M21S
	LPG (liquid petroleum gas)	M10P	M31V M31S	M31V M31S	M40V M40S	M21S
Fluid control	M15V M15K			M45V M45K		
Firesafe (see Firesafe Sales Brochure)		M10F	M31F	M31F	M40F	M20S

M10V stop valve



- 1/4" to 2 1/2"
- Reduced bore and full bore
- Zinc plated forged carbon steel or forged stainless steel
- Screwed, socket weld and butt weld
- Flanged ANSI 150, ANSI 300, PN16 and PN40
- PTFE seats and seals
- Maximum operating pressure 70 bar g
- Maximum operating temperature 230°C
- Manual operation

Applications:

- Low pressure steam, condensate and process water
- Liquid hydrocarbons
- Edible oil
- Natural gas
- Glycol
- Compressed air
- CO₂

M10S and M10S ISO stop valves



- 1/4" to 2 1/2"
- Reduced bore and full bore
- Zinc plated forged carbon steel or forged stainless steel
- Screwed, socket weld and butt weld
- Flanged ANSI 150, ANSI 300, PN16 and PN40
- PDR 0.8 seats and seals
- Maximum operating pressure 100 bar g
- Maximum operating temperature 260°C
- Manual or Automatic operation

Applications:

- Medium pressure steam
- Thermal oils
- Liquid hydrocarbons
- Mineral oil
- Natural gas
- Industrial gas
- CO₂

M10H ISO stop valve



- 1/4" to 2"
- Reduced bore and full bore
- Zinc plated forged carbon steel or forged stainless steel
- Screwed, socket weld and butt weld
- Flanged ANSI 300 and PN40
- PEEK seats and seals
- Maximum operating pressure 62 bar g
- Maximum operating temperature 315°C
- Manual or Automatic operation

Applications:

- High pressure steam
- Thermal oils
- Edible oil

M10F and M10F ISO stop valves



- 1/4" to 2 1/2"
- Reduced bore and full bore
- Zinc plated forged carbon steel or forged stainless steel
- Screwed, socket weld and butt weld
- Flanged ANSI 150, ANSI 300, PN16 and PN40
- R-PTFE seats and seals
- Maximum operating pressure 62 bar g
- Maximum operating temperature 230°C
- Manual or Automatic operation
- Firesafe certified

Application:

- Firesafe

M10P stop valve



- 1/4" to 2 1/2"
- Reduced bore and full bore
- Zinc plated forged carbon steel or forged stainless steel
- Screwed, socket weld and butt weld
- PDR 0.8 seats and seals
- Maximum operating pressure 140 bar g
- Maximum operating temperature 260°C
- Manual operation

Applications:

- Liquid hydrocarbons
- Liquid petroleum gas

M10HP stop valve



- 1/4" to 2"
- Reduced bore and full bore
- Zinc plated forged carbon steel or forged stainless steel
- Screwed, socket weld and butt weld
- Acetal seats and PEEK seals
- Maximum operating pressure 350 bar g
- Maximum operating temperature 80°C
- Manual or Automatic operation

Applications:

- High pressure gases
- High pressure natural gas

M10T and M10T ISO stop valves



- 1/4" to 2 1/2"
- Reduced bore and full bore
- Zinc plated forged carbon steel or forged stainless steel
- Screwed, socket weld and butt weld
- Flanged ANSI 150, ANSI 300, PN16 and PN40
- UHMWPE seats and seals
- Maximum operating pressure 70 bar g
- Maximum operating temperature 70°C
- Manual or Automatic operation

Applications:

- Teflon free processes

M15V ISO and M15K ISO control valves



- 1/4" to 2 1/2"
- Reduced bore and full bore
- Zinc plated forged carbon steel or forged stainless steel
- Screwed, socket weld and butt weld
- Flanged ANSI 150, ANSI 300 and PN40
- Metal seats and Viton/Kalrez seals
- Maximum operating pressure 21 bar g
- Maximum operating temperature 300°C
- Manual or Automatic operation

Applications:

- Temperature control through flow modulation
- Pressure reduction
- Flow regulation
- Slurry and dirty fluids
- Thermal oils

M60V and M60G stop valves



- 1/4" to 4"
- Reduced bore and full bore
- Complies with FDA regulations
- Electropolished to 16 microinches
- Forged stainless steel
- ISO Tube and Tri-clamp connections
- Virgin PTFE or Glass fibre R-PTFE seats
- Maximum operating pressure 62 bar g
- Maximum operating temperature 200°C
- Manual or Automatic operation

Applications:

- Clean steam

M31V ISO stop valve



- DN50 to DN200
- Full bore
- Zinc plated cast carbon steel or cast stainless steel
- Flanged ANSI 150, ANSI 300 and PN16
- PTFE seats and seals
- Maximum operating pressure 51 bar g
- Maximum operating temperature 200°C
- Manual or Automatic operation

Applications:

- Low pressure steam
- Condensate
- Oils
- Gases

M31S ISO and M31H ISO stop valves



- DN50 to DN200
- Full bore
- Zinc plated cast carbon steel or cast stainless steel
- Flanged ANSI 150, ANSI 300 and PN16
- PDR 0.8 and PEEK seats and seals
- Maximum operating pressure 51 bar g
- Maximum operating temperature 260°C (M31S) / 310°C (M31H)
- Manual or Automatic operation

Applications:

- M31S ISO**
 - Medium pressure steam
 - Condensate and process water
 - Edible oils
 - Natural and Industrial gas
 - Glycol
 - Compressed air
 - CO₂
 - Liquid petroleum gas
- M31H ISO**
 - High pressure steam
 - Thermal and edible oils

M31T ISO stop valve



- DN50 to DN200
- Full bore
- Zinc plated cast carbon steel or cast stainless steel
- Flanged ANSI 150, ANSI 300 and PN16
- UHMWPE seats and seals
- Maximum operating pressure 51 bar g
- Maximum operating temperature 70°C
- Manual or Automatic operation

Applications:

- Teflon free processes

M31F ISO stop valve



- DN50 to DN200
- Full bore
- Zinc plated cast carbon steel or cast stainless steel
- Flanged ANSI 150 and ANSI 300
- PDR 0.8 seats and seals
- Maximum operating pressure 51 bar g
- Maximum operating temperature 260°C
- Manual or Automatic operation
- Firesafe certified

Applications:

- Firesafe

M32S ISO (Trunnion) stop valve



- DN50 to DN200
- Full bore
- Zinc plated cast carbon steel or cast stainless steel
- Flanged ANSI 150 and ANSI 300
- PDR 0.8 seats and seals
- Maximum operating pressure 51 bar g
- Maximum operating temperature 260°C
- Manual or Automatic operation
- Trunnion mounted

Applications:

- Natural gas
- Oils
- Hydrocarbons

M40V ISO stop valve



- DN25 to DN150
- Reduced bore
- Zinc plated cast carbon steel or cast stainless steel
- Flanged ANSI 150 and ANSI 300
- PTFE seats and seals
- Maximum operating pressure 51 bar g
- Maximum operating temperature 200°C
- Manual or Automatic operation

Applications:

- Low pressure steam, condensate and process water
- Edible oil
- Natural gas
- Industrial gases
- Glycol
- CO₂

M40S ISO stop valve



- DN25 to DN150
- Reduced bore
- Zinc plated cast carbon steel or cast stainless steel
- Flanged ANSI 150 and ANSI 300
- PDR 0.8 seats and R-PTFE seals
- Maximum operating pressure 51 bar g
- Maximum operating temperature 260°C
- Manual or Automatic operation

Applications:

- Medium pressure steam
- Thermal oils
- Mineral oils
- Liquid hydrocarbons
- Edible oils
- Natural gas
- Industrial gases
- Glycol
- CO₂

M40F ISO stop valve



- DN25 to DN150
- Reduced bore
- Zinc plated cast carbon steel or cast stainless steel
- Flanged ANSI 150 and ANSI 300
- PDR 0.8 seats and R-PTFE seals
- Maximum operating pressure 51 bar g
- Maximum operating temperature 260°C
- Manual or Automatic operation
- Firesafe certified

Applications:

- Firesafe

M42S ISO (Trunnion) stop valve



- DN50 to DN150
- Reduced bore
- Zinc plated cast carbon steel or cast stainless steel
- Flanged ANSI 150 and ANSI 300
- PDR 0.8 seats and seals
- Maximum operating pressure 51 bar g
- Maximum operating temperature 260°C
- Manual or Automatic operation
- Trunnion mounted

Application:

- Natural gas
- Oils
- Hydrocarbons

M21S ISO stop valve



- DN15 to DN100
- Reduced bore
- Zinc plated cast carbon steel or cast stainless steel
- Flanged PN40 DIN 3202 (F4)
- PDR 0.8 seats and R-PTFE seals (Teflon free seats are also available)
- Maximum operating pressure 40 bar g
- Maximum operating temperature 230°C
- Manual or Automatic operation

Applications:

- Medium pressure steam, condensate and process water
- Oils (Thermal and edible)
- Gases
- Glycol
- LPG
- CO₂ liquid

M45V ISO and M45K ISO control valves



- DN25 to DN150
- Reduced bore
- Zinc plated cast carbon steel or cast stainless steel
- Flanged ANSI 150 and ANSI 300
- Metal seats (stainless steel) and PEEK seals
- Maximum operating pressure 21 bar g
- Maximum operating temperature 300°C
- Manual or Automatic operation

Applications:

- Temperature control
- Pressure reduction
- Flow modulation
- Slurry and dirty fluids
- Edible oils

M20H and M20S stop valves



- DN25 to DN150
- Reduced bore
- Zinc plated cast carbon steel or cast stainless steel
- Flanged ANSI 150, ANSI 300 and PN40
- PDR 0.8 and PEEK seats and seals
- Maximum operating pressure 51 bar g
- Maximum operating temperature 260°C (M20S) / 310°C (M20H)
- Manual or Automatic operation

Applications:

- M20H**
- High pressure steam
- Thermal oils

M20S

- Boiler blowdown

Ball valve accessories

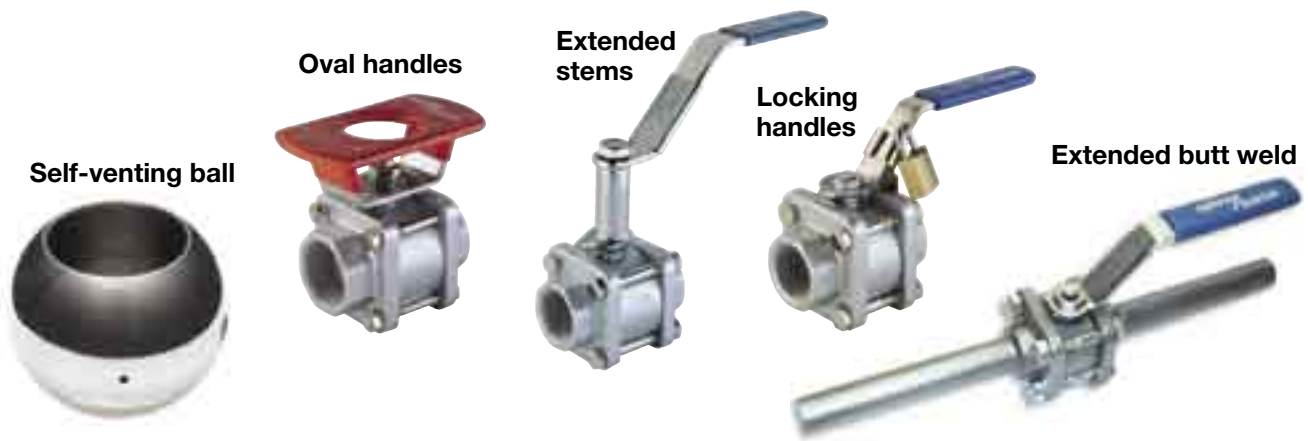

Actuated ball valves

Actuated ball valves operate plant and processes remotely. This can be achieved via local control or large networked systems. Spirax Sarco ball valves with ISO mounting are suitable whatever the control system.

Actuation is very easy with the Spirax Sarco ball valve range. ISO versions are made to simplify the automation process and contain the following advantages:

- Designed to ISO 5211 standard
- Valves can be automated in service
- Easy maintenance
- Stainless steel linkage kits

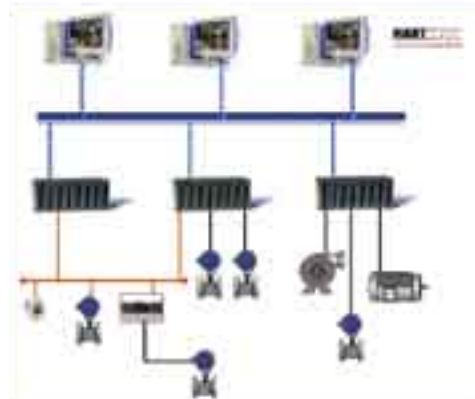

2" M40S ISO ball valve with actuator and limit switch box



4" M31V ISO ball valve with pneumatic actuator and gearbox



1" M10S ISO ball valve with actuator

Selection of actuators

A comprehensive range of actuators provides cost effective selection.

Smaller actuators are required because of low torque valves.

Actuators can operate with compressed air between 3 bar g and 6 bar g.

Electric actuators are also available.

Actuator accessories

A wide range of accessories is available to suit all applications:

Positioners for accurate and stable control.
Manual actuators and handwheels for easy operation of large size valves.
Limit switch boxes for remote signalling of valve position.
Solenoid valves for automatic switching of valve.

Global capabilities

A partnership with Spirax Sarco provides knowledge, service and products worldwide for the control and efficient use of steam and other industrial fluids.

Spirax Sarco have their own companies and sales offices spanning the globe, plus a large number of authorised distributors, providing total coverage.

Technical support

The strength of our worldwide Group is used to meet local needs.

We have over 800 sales engineers on hand to offer technical support, guidance and system design expertise.

After sales service

Help is only a phone call away – our worldwide network of service engineers can offer assistance with installation, commissioning, troubleshooting and maintenance. We hold comprehensive local stocks of products worldwide. Spirax Sarco offer a range of tailored service packages, from steam system audits and process efficiency investigations to comprehensive steam system management contracts.

Worldwide training

Our philosophy is to share our knowledge with our customers on the efficient use and application of steam and industrial fluids. We do so with the help of over 35 training centres spread around the globe, and our range of correspondence courses, which so far have been completed by over a million students.

Product range

Steam traps and pipeline ancillaries, EL, PN and self-acting control systems, automation, flowmetering, boiler controls, packaged systems, condensate removal and energy recovery...



Some of the products may not be available in certain markets.

Spirax-Sarco Limited, Charlton House,
Cheltenham, Gloucestershire, GL53 8ER UK.
Tel: +44 (0)1242 521361 Fax: +44 (0)1242 573342
E-mail: Enquiries@SpiraxSarco.com
Internet: www.SpiraxSarco.com

© Copyright 2006 Spirax Sarco is a registered trademark of Spirax-Sarco Limited

spirax /sarco

SB-S39-06

ST Issue 2