

EL7000

Series Electric Linear Actuators
Installation and Maintenance Instructions

EL7200



- 1. Safety information*
- 2. General product information*
- 3. Installation and Commissioning*
- 4. Spare parts*



1. Safety information

Safe operation of these products can only be guaranteed if they are properly installed, commissioned, used and maintained by qualified personnel (see Section 1.13) in compliance with the operating instructions. General installation and safety instructions for pipeline and plant construction, as well as the proper use of tools and safety equipment must also be complied with.

See separate Installation and Maintenance Instructions for the control valve.



If the actuator is handled improperly or not used as specified, the resultant may:

- cause danger of the life and limb of the third party,
- damage the actuator and other assets belonging to the owner,
- hinder the performance of the actuator.

1.1 Wiring notes

Every effort has been made during the design of the actuator to ensure the safety of the user, but the following precautions must be followed:

- i) Maintenance personnel must be suitably qualified in working with equipment containing hazardous live voltages.
- ii) Ensure correct installation. Safety may be compromised if the installation of the product is not carried out as specified in this manual.
- iii) Isolate the actuator from the mains supply before opening the unit.
- iv) The actuator is designed as an installation category II product, and is reliant on the building installation for overcurrent protection and primary isolation.
- v) Wiring should be carried out in accordance with IEC 60364 or equivalent.
- vi) Fuses should not be fitted in the protective earth conductor. The integrity of the installation protective earth system must not be compromised by the disconnection or removal of other equipment.
- vii) A disconnecting device (switch or circuit breaker) must be included in the building installation. This must be in close proximity to the equipment and within easy reach of the operator.
 - There must be a 3 mm contact separation in all poles.
 - It must be marked as the disconnecting device for the actuator.
 - It must not interrupt the protective earth conductor.
 - It must not be incorporated into a mains supply cord.
 - The requirements for the disconnecting device are specified in IEC 60947-1 and IEC 60947-3 or equivalent.
- viii) The actuator must not be located in such a way that the disconnecting device is made difficult to operate.

1.2 Safety requirements and electromagnetic compatibility

Product: Electrical linear actuators
Type: EL7211A-SE and EL7212A-SE
Conform with the following Directives:

Council Directive 2006/95/EC: of 16 January 2007 on the harmonisation of the laws of the Member States relating to electrical equipment designed for use within certain voltage limits 'low voltage'.

Council Directive 2004/108/EC: of 20 January 2005 on the approximation of the laws of the Member States relating to electromagnetic compatibility.

Product: Electrical linear actuators
Type: EL7213A-SE
Conform with the following Directive:

Council Directive 2004/108/EC: of 20 January 2005 on the approximation of the laws of the Member States relating to electromagnetic compatibility.

The product may be exposed to interference above the limits of industrial immunity if:

- The product or its wiring is located near to a radio transmitter.
- Excessive electrical noise occurs on the mains supply.
- Cellular telephones and mobile radios may cause interference if used within approximately one metre of the product or its wiring. The actual separation necessary will vary according to the power of the transmitter.
- Power line protectors (ac) should be installed if mains supply noise is likely.
- Protectors can combine filtering, suppression, surge and spike arrestors.

1.3 Intended use

Referring to the Installation and Maintenance Instructions, name-plate and Technical Information Sheet, check that the product is suitable for the intended use/application.

- i) Check material suitability, pressure and temperature and their maximum and minimum values. If the maximum operating limits of the product are lower than those of the system in which it is being fitted, or if malfunction of the product could result in a dangerous overpressure or overtemperature occurrence, ensure a safety device is included in the system to prevent such over-limit situations.
- ii) Determine the correct installation situation.
- iii) Spirax Sarco products are not intended to withstand external stresses that may be induced by any system to which they are fitted. It is the responsibility of the installer to consider these stresses and take adequate precautions to minimise them.

1.4 Access

Ensure safe access and if necessary a safe working platform (suitably guarded) before attempting to work on the product. Arrange suitable lifting gear if required.

1.5 Lighting

Ensure adequate lighting, particularly where detailed or intricate work is required.

1.6 Hazardous liquids or gases in the pipeline

Consider what is in the pipeline or what may have been in the pipeline at some previous time. Consider: flammable materials, substances hazardous to health, extremes of temperature.

1.7 Hazardous environment around the product

Consider: explosion risk areas, lack of oxygen (e.g. tanks, pits), dangerous gases, extremes of temperature, hot surfaces, fire hazard (e.g. during welding), excessive noise, moving machinery.

1.8 The system

Consider the effect on the complete system of the work proposed. Will any proposed action (e.g. closing isolation valves, electrical isolation) put any other part of the system or any personnel at risk?

Dangers might include isolation of vents or protective devices or the rendering ineffective of controls or alarms. Ensure isolation valves are turned on and off in a gradual way to avoid system shocks.

1.9 Pressure systems

Ensure that any pressure is isolated and safely vented to atmospheric pressure. Consider double isolation (double block and bleed) and the locking or labelling of closed valves. Do not assume that the system has depressurised even when the pressure gauge indicates zero.

1.10 Temperature

Allow time for temperature to normalise after isolation to avoid danger of burns.

1.11 Tools and consumables

Before starting work ensure that you have suitable tools and/or consumables available. Use only genuine Spirax Sarco replacement parts.

1.12 Protective clothing

Consider whether you and/or others in the vicinity require any protective clothing to protect against the hazards of, for example, chemicals, high/low temperature, radiation, noise, falling objects, and dangers to eyes and face.

1.13 Permits to work

All work must be carried out or be supervised by a suitably competent person. Installation and operating personnel should be trained in the correct use of the product according to the Installation and Maintenance Instructions.

Where a formal 'permit to work' system is in force it must be complied with. Where there is no such system, it is recommended that a responsible person should know what work is going on and, where necessary, arrange to have an assistant whose primary responsibility is safety.

Post 'warning notices' if necessary.

1.14 Handling

Manual handling of large and/or heavy products may present a risk of injury. Lifting, pushing, pulling, carrying or supporting a load by bodily force can cause injury particularly to the back. You are advised to assess the risks taking into account the task, the individual, the load and the working environment and use the appropriate handling method depending on the circumstances of the work being done.

1.15 Residual hazards

In normal use the external surface of the product may be very hot. If used at the maximum permitted operating conditions the surface temperature of some products may reach temperatures of 90°C (194°F).

Many products are not self-draining. Take due care when dismantling or removing the product from an installation (refer to 'Maintenance instructions').

1.16 Freezing

Provision must be made to protect products which are not self-draining against frost damage in environments where they may be exposed to temperatures below freezing point.

1.17 Disposal

Unless otherwise stated in the Installation and Maintenance Instructions, this product is recyclable and no ecological hazard is anticipated with its disposal providing due care is taken.

1.18 Returning products

Customers and stockists are reminded that under EC Health, Safety and Environment Law, when returning products to Spirax Sarco they must provide information on any hazards and the precautions to be taken due to contamination residues or mechanical damage which may present a health, safety or environmental risk. This information must be provided in writing including Health and Safety data sheets relating to any substances identified as hazardous or potentially hazardous.

— 2. General product information —

2.1 Description

EL7000 series electric linear actuators are for use with SPIRA-TROL series two-port control valves, QL three-port control valves and all bellows sealed options.

Actuators will normally be supplied fitted to the control valve. When supplied separately, ensure the actuator selected is capable of giving the force necessary to close the two-port or three-port valve against the expected differential pressure.

Note:

For further product data refer to the Technical Information Sheet. EL7000 series actuators are available for VMD (Valve motor drive) input or modulating control (0/4 - 20 mA or 0/2 - 10 Vdc) inputs. The following voltage options are available: 230 Vac, 115 Vac and 24 Vac.

2.2 Operation

The drive mechanism consists of a stepper motor and a gear train that converts a rotary to linear motion. An integral Hall effect sensor provides position feedback throughout the stroke and motor, travel limits are achieved by measurement of the thrust at these points.

2.3 Manual operation

The integral handwheel is used to operate the actuator if the power supply has failed during installation work such as mounting onto a valve.

Caution: If the handwheel is in the manual mode the actuator will not respond to the input signal.



Auto



Manual

Fig. 1 EL7200 series

— 3. Installation and Commissioning —

Please read Section 1, 'Safety information' before proceeding with the installation.

3.1 Location

The preferred mounting of the actuator should be above the valve with sufficient space to remove the cover and general ease of access, however side mounting is permitted. **Do not install the actuator below the valve.**

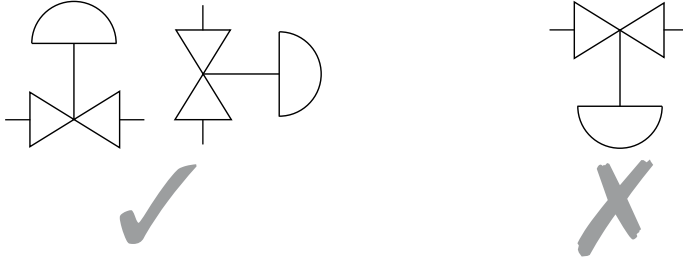

Fig. 2

When selecting the location, make sure that the actuator is not exposed to an ambient temperature outside the range -0°C to $+60^{\circ}\text{C}$. If necessary, provide ventilation for the actuator to prevent overheating. Only Insulate the valve and pipework: **DO NOT** insulate the actuator. The actuator is rated at IP54 as standard, but only when the lid is correctly fitted. It is recommended that adequate shelter be provided for outdoor installations.

3.2 Connecting the EL7200 series actuator to the valve

A1. Check that the label fixed to the end of the carton matches the actuator model requested.



A1



A2

A2. Remove the actuator from the carton and again check that that the product name-plate matches the actuator model requested.

A3. Cut the tie wrap to free the spacer ring.

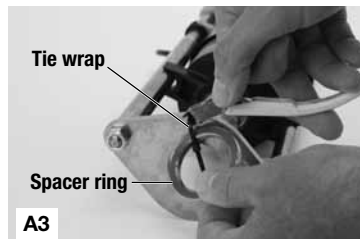

A3

B. Remove the circlip and pin to release the connector.

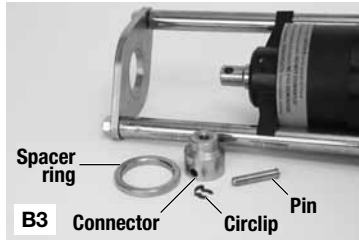
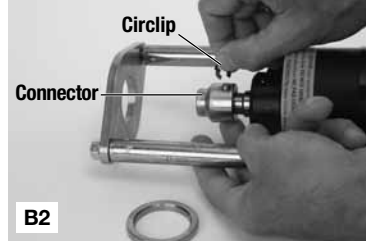

C. Remove the actuator mounting nut from the valve bonnet; screw the lock-nut down the valve spindle as far as it will go.

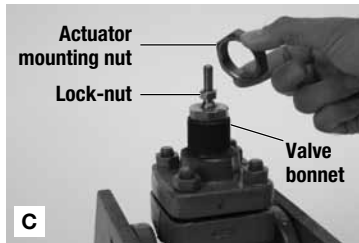

D. Screw the connector onto the valve spindle (**D1**). Adjust until the spindle is about **2 threads below** the inside lower face of the connector (**D2**). Push the spindle down and ensure that the plug is on the seat (**D3**).

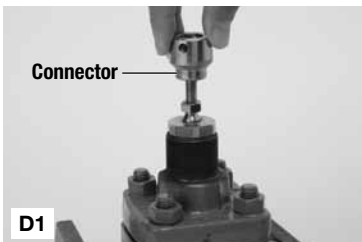

-
- E. Mount the actuator onto the valve bonnet together with the spacer ring and the mounting nut (E1). Finger tighten the actuator mounting nut to secure the assembly (E2), torque to 50 Nm (E3)

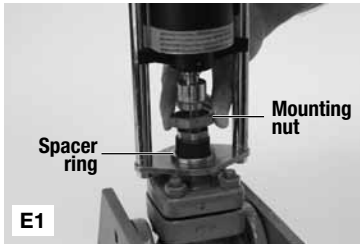

- F. Loosen both of the M8 nuts that secure the mounting plate to the pillars, and unscrew them by at least three full turns.



- G. Rotate the connector up or down until the cross-drilled holes are perfectly aligned and the clevis pin passes through easily. Then **remove** the pin.



- H. Rotate the connector 1½ turns up** the spindle so that the holes are no longer aligned. Lift the actuator up so that the cross-holes are aligned once more. Insert the pin from the front (**H1**) and finally secure with the circlip at the rear (**H2**).

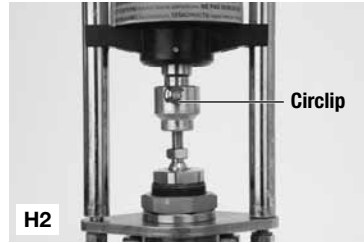

- I. A 2 mm space (1a)** should now exist between the lower end of the pillars and the mounting plate (**1a**). Torque the M8 nuts to 20 Nm until the pillars are secured tightly against the mounting plate (**1b**).

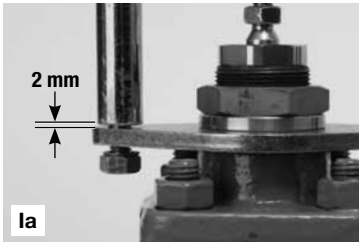

- J. Use a wide bladed screwdriver to open the cover (J1).** Inside the cover is a ribbon cable connected to the main circuit board (**J2**). Note orientation then gently pull on the cable to remove it from the pin header on the circuit board (**J3**).

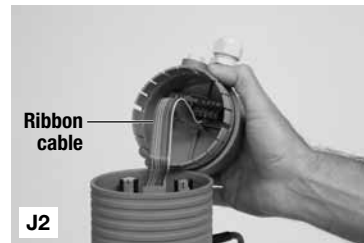

K. Check the fitting of the jumper (JP2) for input signal type.

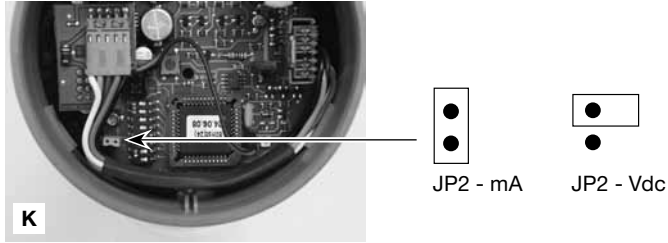

L. Use a small pointed tool to move switches, and set as required - see Table 1.

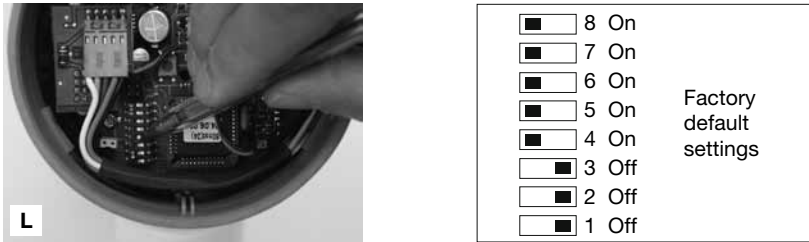

Fig. 3

Table 1

Switch	Feature	ON	OFF
1	Position feedback signal X (0 - 10 V)	Actuator extend → 10 V Actuator retract → 0 V	Actuator extend → 0 V Actuator retract → 10 V
2	Input signal Y	Y_{min} → actuator retract Y_{max} → actuator extend	Y_{min} → actuator extend Y_{max} → actuator retract
3	Input signal span Y	0 - 10 V or 0 - 20 mA	2 - 10 V or 4 - 20 mA
4	Actuator speed	4 s/mm	6 s/mm
5	NOT USED		
6	Safe position (retract or extend)	↓	↑
7 and 8	Input signal hysteresis (volts)	0.50	7 and 8
		0.30	7
		0.15	-
		0.05	8

Notes:

- i) S6 is set to determine the fail safe position in the event of input signal failure.
- ii) Using the actuator in VMD operating mode temporarily disables response to analogue signals on terminal 'Y'. Repeat the automatic calibration (Step 'Q' onwards) to re-enable the 'Y' input.

M. Make sure that the actuator is switched to manual operation by pulling the handwheel upwards until it clicks into the manual position.



N. Check the required supply voltage from details on the name-plate.

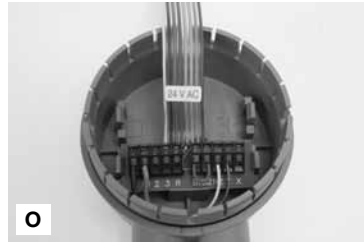

O. Make electrical connections:

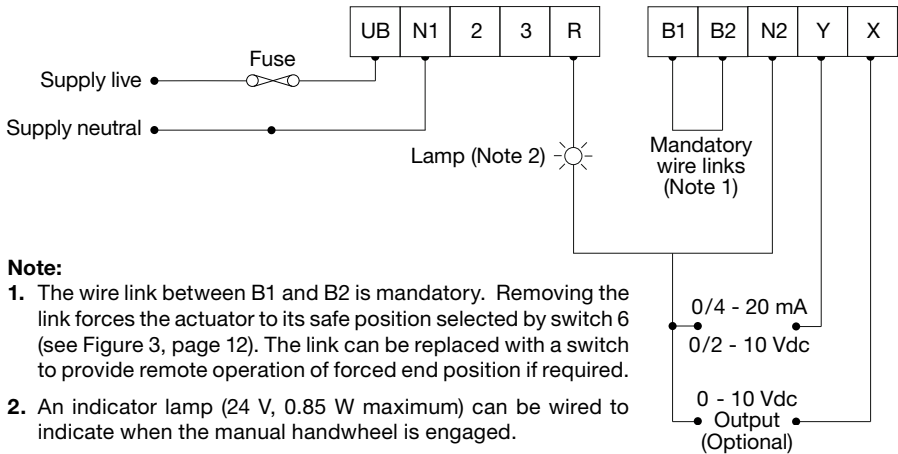

Note:

1. The wire link between B1 and B2 is mandatory. Removing the link forces the actuator to its safe position selected by switch 6 (see Figure 3, page 12). The link can be replaced with a switch to provide remote operation of forced end position if required.
2. An indicator lamp (24 V, 0.85 W maximum) can be wired to indicate when the manual handwheel is engaged.
3. Terminals 2 + 3 are not used.

Fig. 4 EL721_A-SE mA/volts applications

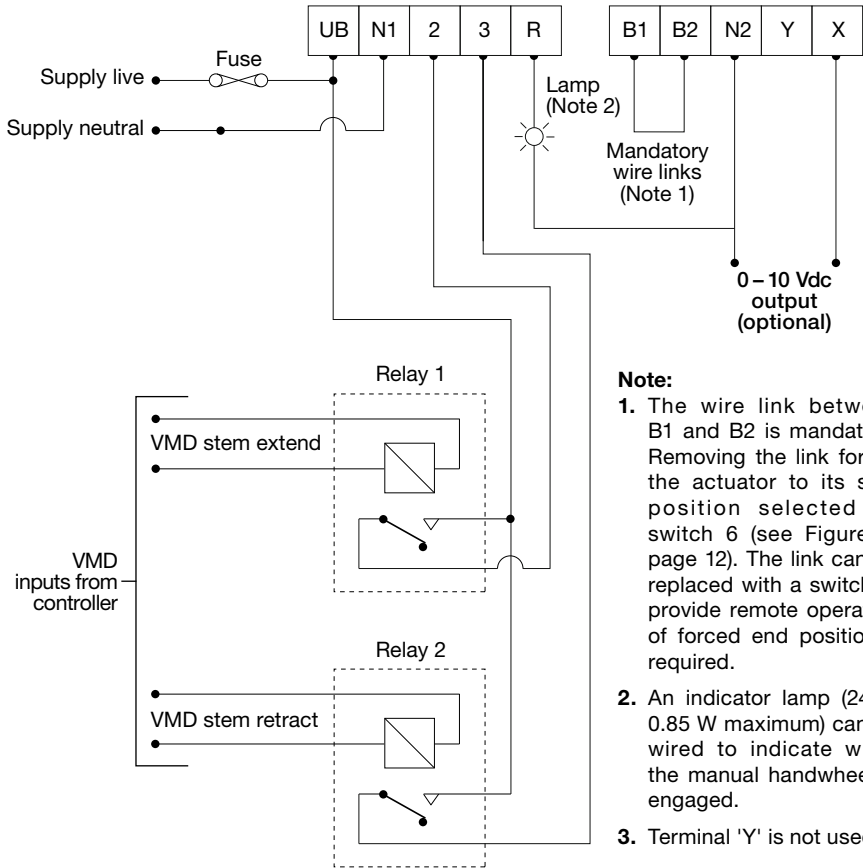

Fig. 5 EL721_A-SE VMD application

P. Re-fit the ribbon connector to the pin header. Ensure the plug is inserted the right way round, see Figure 6.

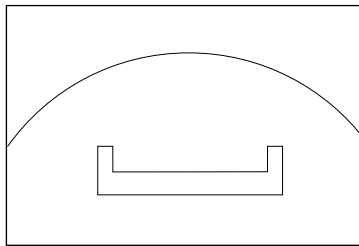

Fig. 6

Q. (a) Switch on the power supply.

(b) Apply a mA or voltage control signal to terminal 'Y', or alternatively a switched live (VMD stem extend) signal to terminal 2.

R. Press down on the handwheel to begin the automatic calibration sequence.

Note: The auto calibration sequence may take up to 2½ minutes to complete.



S. Note: the handwheel starts to rotate left to right and the yellow LED starts to flash 50% on 50% off.



T. Note: The spring pack slowly compresses.



The yellow LED 50/50 flashing continues until the spring pack is fully compressed. When fully compressed the motor switches off.

U. Wait for approximately 30 seconds.

Depending on the input signal and switch settings (Table 1) the actuator will either:

(a) remain in the fully extended position whilst the yellow LED shines steadily.

or

(b) start to retract the spindle whilst the yellow LED continues to flash.

In both cases, press and hold the 'Init' button (Step 'S') for approximately 3 seconds - See note below.

Note: Pressing of the 'Init' button will not be detected by the software whilst the spindle is extending. It must thus be pressed whilst the spindle is either stationary or retracting.



V. The actuator stem will now retract together with the fully compressed and latched spring pack.



When fully retracted the motor will switch off. Again wait approximately 30 seconds, after which the automatic calibration will be complete. The actuator should now respond to changes of the input signal.

Note: If the set point position is different to the fully retracted position the actuator stem will now motor to that set point position. When set point is reached the motor will switch off until the set point is changed once more.

3.3 Now the setting must be checked:

1. For actuators set to accept an analogue input into terminal 'Y':

- **Increase the input signal to 25% of span:**
 - (a) The handwheel will start to rotate right to left and the valve stem will start to lift.
 - (b) The actuator stops when the valve is 25% open.
- **Increase the input signal to 50% of span** - Wait for the actuator to move toward the mid travel position.
- **Reduce the input signal to 25% of span** - The actuator stops, then reverses back down towards the 25% open position.
- **Then set the minimum input signal** - Allow the valve to close fully.
- **Finally increase the input signal to 25%.**

Wait until the actuator stops at the 25% open position.

2. For actuators set to accept VMD signals

check to ensure that the actuator responds correctly: Apply a VMD signal on terminals 2 to make the actuator stem extend or terminal 3 to make it retract.

3. Check the 0-10 Vdc output

Ensure this signal changes as the actuator stem extends and retracts.

4. Check the remote indicator lamp (if connected)

If a lamp or indicator is connected to terminal 'R', ensure it switches on correctly when the handwheel is set to the manual position.

3.4 Important

The valve plug is not touching the valve seat so the lock-nut on the valve spindle may be safely tightened without risk of damage to the valve seat.

W. Tighten the coupling lock-nut.



X. Turn off the power and check the actuator releases the spring pack to ensure the spring pack closes the valve.

Y. Remove the loop calibrator connection and replace with the process signal connections. Re-fit the cover and ensure it is correctly located.

3.5 Commissioning is now complete

Diagnostics and failure modes

Normal operation (after commissioning):

1. When the actuator is on set point, the motor stops and the yellow LED will shine steadily without flashing.
2. When the control signal is changed the actuator will motor towards set point and the yellow LED will flash 50/50.

Control signal failure:

1. If just the control signal fails during normal operation, the actuator will motor directly to the 'SAFE' position pre-determined by the setting of switch S6 (either fully extended or fully retracted). The yellow LED will flash 20/80 until the control signal is restored and the spring pack will remain compressed and latched.
2. When the control signal is restored, the actuator will motor directly back to the set point called for by the control signal, accompanied by the LED flashing 50/50. When set point is reached the motor will switch off again and the yellow LED will shine steadily without flashing.

Power supply failure:

1. If the power supply fails during normal operation, the actuator spring pack latch will be released immediately and the spring pack will extend to slam the valve closed within two or three seconds. The valve will remain tightly closed until power is restored.
2. When the power is restored, the actuator will first re-compress the spring pack until it re-latches, then motor directly to the set point called for by the control signal. Re-calibration is not required after power failure and will not occur automatically. However, it may be repeated at any time by pressing the 'Init' button. It should always be repeated if any mechanical adjustment is made with the actuator or valve.

Blocked/seized valve

Caution: In the event of a blockage between the valve seat and plug the actuator will partially open and close seven times (trying to clear the blockage). If this is unsuccessful the actuator will stop in the semi open position and the yellow LED will flash rapidly.

Dismantling the actuator from the valve

If it is required to dismantle the actuator from the valve, to prevent damage to the product and potential injury to personnel, **always** ensure the actuator stem is fully retracted (using the handwheel if required) before removing the pillar nuts from the actuator. **Never** attempt to dismantle the spring pack from the actuator.

5. Spare parts

Available spares

EL7200	Mounting flange	(DN15 - DN50) EL7021	4
	Linkage for SPIRA-TROL LE and KE series control valves	(DN15 - DN50) EL7020	3
SA linkage kit		(DN15 - DN50) EL7012	

How to order spares

Always order spares by using the description given above and state the size of the control valve that the actuator is coupled to.

Example: 1 off EL7021 mounting flange for an EL7200 actuator that is coupled to a DN50 SPIRA-TROL KE series control valve.

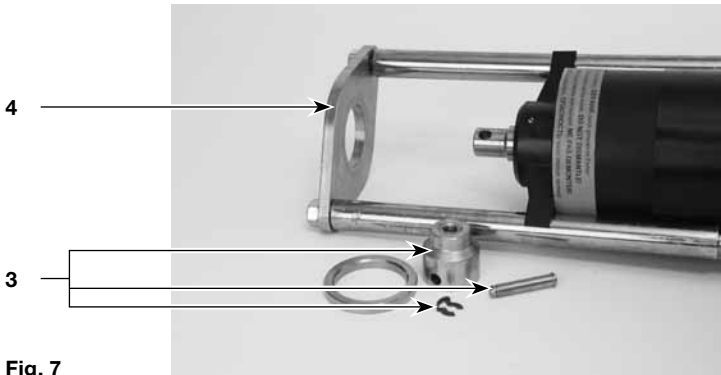

Fig. 7

