

DIVA Essential Installation Guide

This guide must be read in conjunction with the Installation and Maintenance Instructions (IM-P337-36) supplied with product.

This guide highlights the minimum installation requirements to ensure that the product performs to user expectations.

See IM-P337-36, page 14 for further details

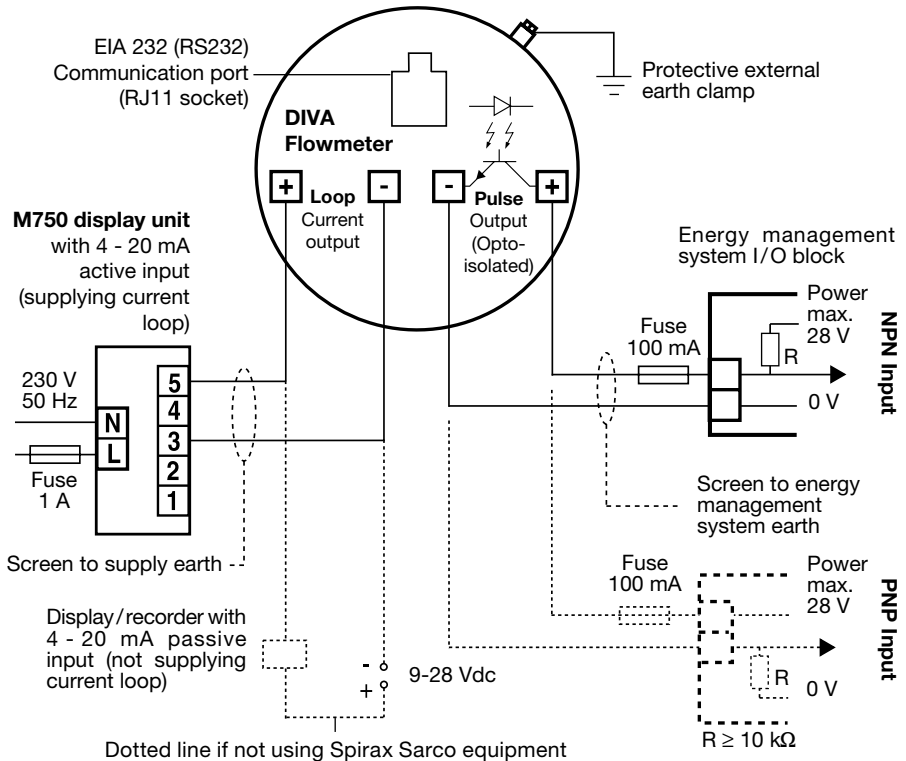

Cable size: 0.5 mm²
Maximum length: 300 m
Voltage: 9 - 28 Vdc

Now proceed to
Programming, Section 4.2 on IM-P337-36

Horizontal installation

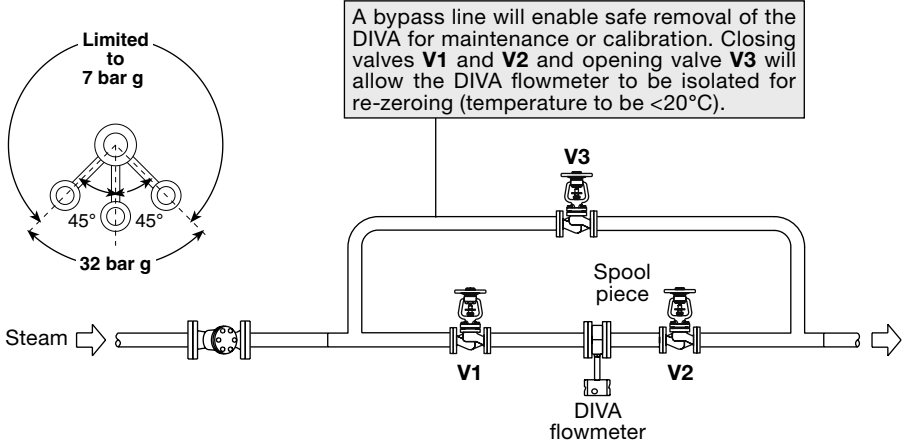

Vertical installation

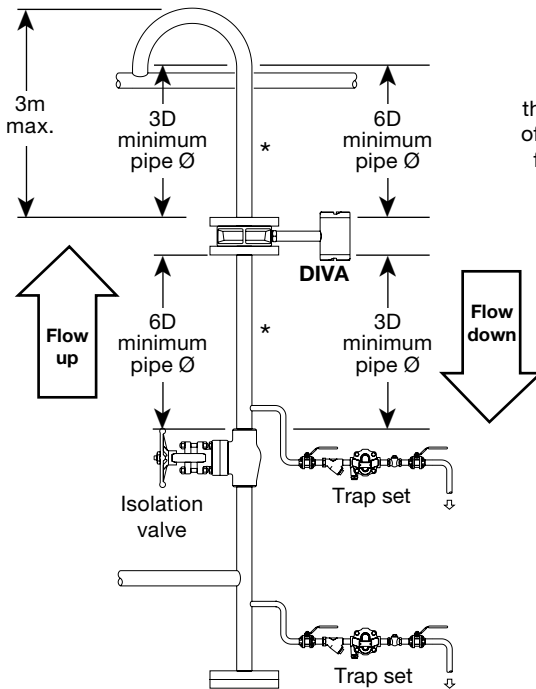

Vertical installation Limited to 7 bar g

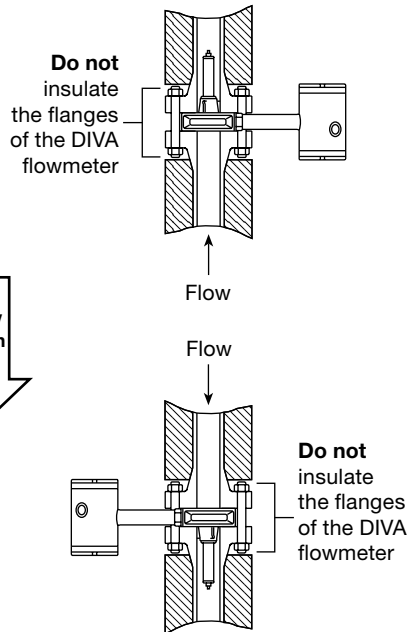

* A spool piece may be fitted to the downstream side of the DIVA flowmeter - see above.