

---

---

**TC10 Pulsed Output Timer Control  
for Steam Main Warm-up  
Installation and Maintenance Instructions**

---

---

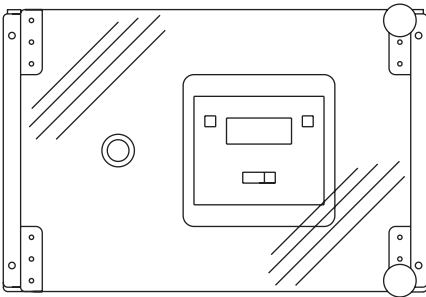

- 1. Safety information*
- 2. General  
product information*
- 3. Installation*
- 4. Commissioning*



---

# 1. Safety information

---

In the UK, your attention is drawn to IEE Regulations (BS 7671). Elsewhere, other regulations will normally apply.

Pressure equipment not bearing the C€ mark is classified 'Sound Engineering Practice' in accordance with Article 3, Paragraph 3 of the Pressure Equipment Directive 97/23/EC. It is the responsibility of the user to ensure that the product is installed and operated safely.

Safe operation of these products can only be guaranteed if they are properly installed, commissioned, used and maintained by qualified personnel (see Section 1.11) in compliance with the operating instructions. General installation and safety instructions for pipeline and plant construction, as well as the proper use of tools and safety equipment must also be complied with.

Detailed product information can be obtained from [www.SpiraxSarco.com](http://www.SpiraxSarco.com) or by contacting your local Spirax Sarco sales office.

Note: By law, SEP products cannot be marked with the C€ symbol.

## 1.1 Intended use

- i) Check that the product is suitable for use with the intended fluid.
- ii) Check material suitability, pressure and temperature and their maximum and minimum values. If the maximum operating limits of the product are lower than those of the system in which it is being fitted, or if malfunction of the product could result in a dangerous overpressure or overtemperature occurrence, ensure a safety device is included in the system to prevent such over-limit situations.
- iii) Determine the correct installation situation and direction of fluid flow.
- iv) Spirax Sarco products are not intended to withstand external stresses that may be induced by any system to which they are fitted. It is the responsibility of the installer to consider these stresses and take adequate precautions to minimise them.
- v) Remove protection covers from all connections before installation.

## 1.2 Access

Ensure safe access and if necessary a safe working platform (suitably guarded) before attempting to work on the product. Arrange suitable lifting gear if required.

## 1.3 Lighting

Ensure adequate lighting, particularly where detailed or intricate work is required.

## 1.4 Hazardous liquids or gases in the pipeline

Consider what is in the pipeline or what may have been in the pipeline at some previous time. Consider: flammable materials, substances hazardous to health, extremes of temperature.

## 1.5 Hazardous environment around the product

Consider: explosion risk areas, lack of oxygen (e.g. tanks, pits), dangerous gases, extremes of temperature, hot surfaces, fire hazard (e.g. during welding), excessive noise, moving machinery.

---

## 1.6 The system

Consider the effect on the complete system of the work proposed. Will any proposed action (e.g. closing isolation valves, electrical isolation) put any other part of the system or any personnel at risk?

Dangers might include isolation of vents or protective devices or the rendering ineffective of controls or alarms. Ensure isolation valves are turned on and off in a gradual way to avoid system shocks.

## 1.7 Pressure systems

Ensure that any pressure is isolated and safely vented to atmospheric pressure. Consider double isolation (double block and bleed) and the locking or labelling of closed valves. Do not assume that the system has depressurised even when the pressure gauge indicates zero.

## 1.8 Temperature

Allow time for temperature to normalise after isolation to avoid danger of burns.

## 1.9 Tools and consumables

Before starting work ensure that you have suitable tools and/or consumables available. Use only genuine Spirax Sarco replacement parts.

## 1.10 Protective clothing

Consider whether you and/or others in the vicinity require any protective clothing to protect against the hazards of, for example, chemicals, high/low temperature, radiation, noise, falling objects, and dangers to eyes and face.

## 1.11 Permits to work

All work must be carried out or be supervised by a suitably competent person. Installation and operating personnel should be trained in the correct use of the product according to the Installation and Maintenance Instructions.

Where a formal 'permit to work' system is in force it must be complied with. Where there is no such system, it is recommended that a responsible person should know what work is going on and, where necessary, arrange to have an assistant whose primary responsibility is safety.

Post 'warning notices' if necessary.

## 1.12 Handling

Manual handling of large and/or heavy products may present a risk of injury. Lifting, pushing, pulling, carrying or supporting a load by bodily force can cause injury particularly to the back. You are advised to assess the risks taking into account the task, the individual, the load and the working environment and use the appropriate handling method depending on the circumstances of the work being done.

## 1.13 Residual hazards

In normal use the external surface of the product may be very hot.

Many products are not self-draining. Take due care when dismantling or removing the product from an installation.

---

## 1.14 Freezing

Provision must be made to protect products which are not self-draining against frost damage in environments where they may be exposed to temperatures below freezing point.

## 1.15 Safety information - Product specific

The timer control is intended for opening a steam valve. Safety precautions need to be taken when commissioning and adjusting the timer to avoid unexpected opening of the valve, or faster opening than intended. A competent person familiar with the operation of the steam plant should supervise commissioning and adjustment.

### WARNING

Isolate the mains supply before opening the base of the unit as hazardous voltages may be exposed.

The components in this product comply with the requirements of Electromagnetic Compatibility Directive 89/336/EEC and are CE marked:

The following conditions should be avoided as they may create interference:

- The product or its wiring is located near a radio transmitter.
- Excessive electrical noise occurs on the mains supply. Power line protectors (ac) should be installed if mains supply noise is likely. Protectors can combine filtering, suppression, surge and spike arrestors.
- Cellular telephones and mobile radios may cause interference if used within approximately 1 metre (3 ft) of the product or its wiring. The actual separation distance necessary will vary according to the surroundings of the installation and the power of the transmitter.

All wiring materials and methods shall comply with relevant EN and IEC standards where applicable.

## 1.16 Disposal

Unless otherwise stated in the Installation and Maintenance Instructions, this product is recyclable and no ecological hazard is anticipated with its disposal providing due care is taken.

## 1.17 Returning products

Customers and stockists are reminded that under EC Health, Safety and Environment Law, when returning products to Spirax Sarco they must provide information on any hazards and the precautions to be taken due to contamination residues or mechanical damage which may present a health, safety or environmental risk. This information must be provided in writing including Health and Safety data sheets relating to any substances identified as hazardous or potentially hazardous.

## — 2. General product information —

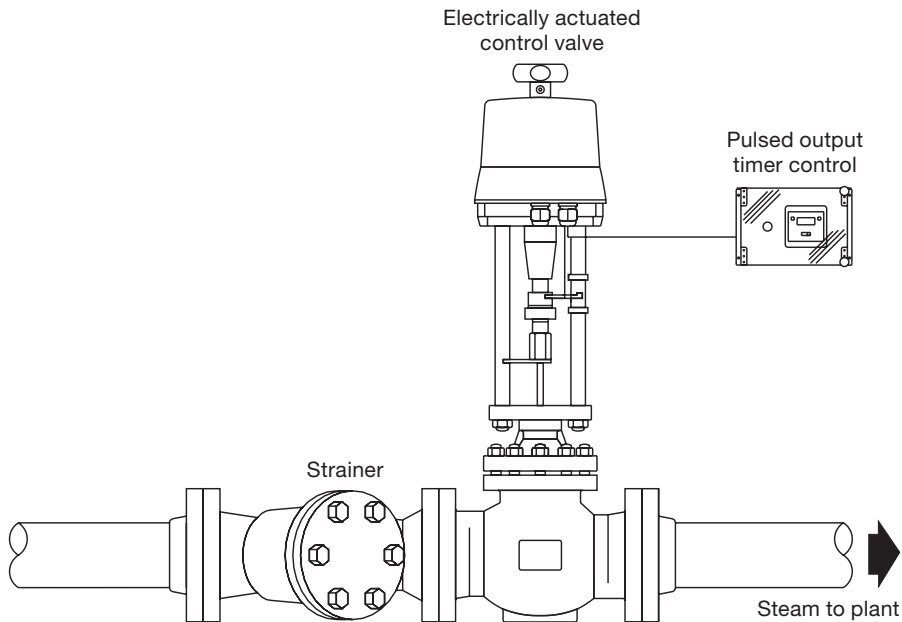

**Fig. 1 Typical installation**

### 2.1 Description

The TC10 pulsed output timer control is intended for the timed opening and closing of an electrically actuated steam isolating valve. It includes an adjustable slow opening feature, used for gently warming through steam mains in order to avoid waterhammer. The pulsed output timer control consists of a wall-mounting enclosure with transparent cover.

The system saves energy by shutting down the steam main when not required.

#### Principal features:

- A 7 day time clock 230 Vac. Used for setting the valve open (ON) and valve close (OFF) times over a 7 day cycle. Up to 6 different ON and OFF times may be set, and applied to the different days of the week.
- DIN rail mounted cycling timer with universal supply. Used for setting the speed at which the valve opens. The speed is controlled by a series of opening pulses, followed by a pause time, so the valve actually opens in small steps.
- Power on indicator.
- Labelled terminal strip.
- Cable entry gland with lock-nut (can be moved to alternative blanked position).

#### Standards

The pulsed output timer control components are **CE** marked and comply with the low voltage and EMC directives.

---

## 2.2 The system

A typical system consists of an electrically actuated control valve used for isolating the steam system at times when steam is not required. Heat losses are therefore dramatically reduced. The pulsed output timer control incorporates a 7 day time clock to initiate the opening of the valve. The valve is opened in a series of short pulses, followed by longer pauses, so that it slowly lets steam back into the system to warm it through steadily.

### Other items that may be required include:

- Upstream manual isolation, condensate drainage and strainer.
- Downstream, good condensate drainage and air venting from the whole system will speed up the warm-through and help to avoid waterhammer.

## 2.3 The valve

The valve would typically be from the Spirax Sarco range of control valves. A pipeline sized control valve is usual, unless the steam pipework is oversized. Depending on the pipeline size the actuator may be single-phase or three-phase. For three-phase systems an actuator with integrated motor controls is usually more convenient. The electric actuator typically incorporates a manual override.

## 2.4 Technical data

---

<b>Enclosure protection</b>	IP65
<b>Ambient temperature range</b>	-10°C to +50°C
<b>Supply voltage for time clock</b>	230 Vac, 50 Hz
<b>Supply voltage for actuator control</b>	24 V to 240 V ac or dc
<b>Time clock setting resolution</b>	1 minute
<b>Time clock battery back-up time</b>	1 000 hours
<b>Fastest valve opening time</b>	Actuator speed
<b>Slowest valve opening time</b>	Virtually unlimited
<b>Valve closing time</b>	Actuator speed

---

---

## 3. Installation

---

### 3.1 Installation of the TC10 pulsed output timer controller

#### 3.1.1 Mechanical installation

Install the TC10 in a location where the ambient temperature never exceeds 50°C, and where there is no excessive radiant heat from other equipment. Avoid areas where there may be excessive electrical interference. Since you may wish to reprogram the valve open and valve close times, choose a convenient location with reasonable lighting levels.

Access to the cycling timer and terminals is achieved by removing the centre pin of one of the hinges on the rear section. Either pin can be removed to allow hinged access on the most convenient side. Some pressure on the unit may be necessary to compress the seals and allow the hinge pin to be removed or inserted.

Access to the time clock is by undoing the two knurled thumb screws on the transparent cover.

#### 3.1.2 Electrical installation - Refer to Figure 2

Wire a 230 Vac mains supply to the terminals marked **L**, **N** and **E**. An external isolating switch should be provided.

Wire the correct valve actuator supply (maximum 230 Vac) to the terminals marked **1**, **2** and **E**. Suitable voltages are 230 Vac, 115 Vac or 24 Vac. An external isolating switch should be provided.

A changeover frost protection thermostat may be connected to terminals marked **3**, **4** and **5**. The frost thermostat will override the time clock and open the valve using the cycling timer in the case of low temperature. If no frost stat is fitted, link terminals **3** and **4**.

Wire the valve actuator to the terminals numbered **6** to **10**. The connection to the valve actuator auxiliary (volt-free) limit switch, switches off the cycling timer when the valve is fully open. If no limit switch is fitted, link terminals **6** and **7**.

The voltage supply for the time clock is 230 Vac. The voltage supply for the recycling timer is 24 V to 240 V ac or dc.

The cycling timer contact that will operate the valve is rated at 5 A, 250 Vac resistive load. The loading of the valve should be within this rating or external auxiliary relays should be used.

**Example of the wiring to an  
EL5600 series actuator,  
with auxiliary limit switch**

Circuit broken  
when valve  
fully open

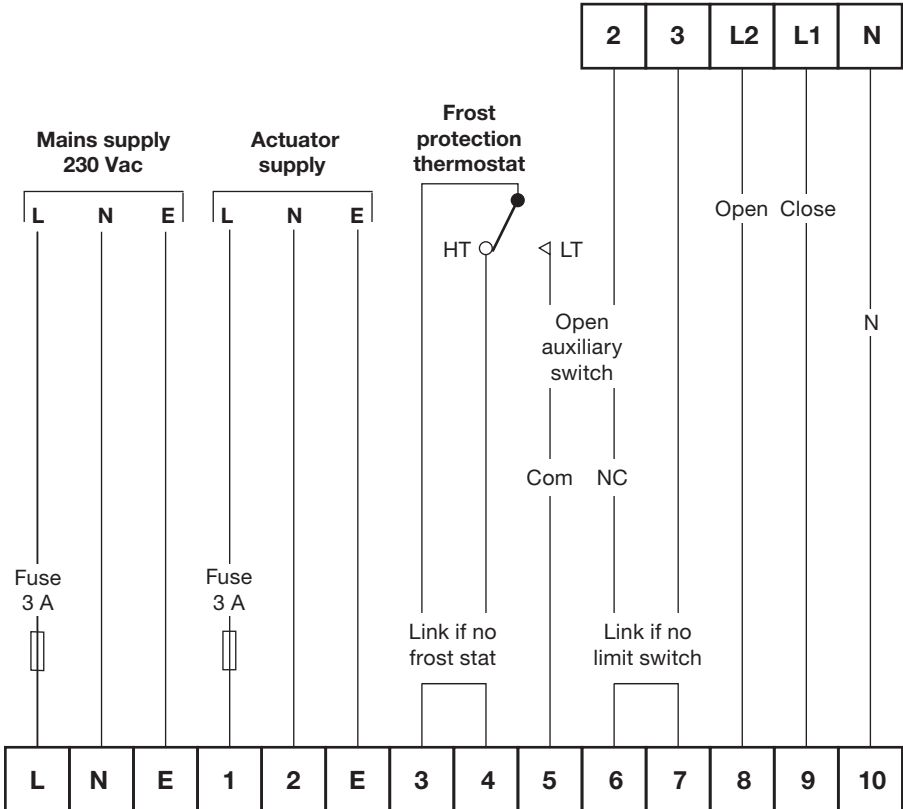
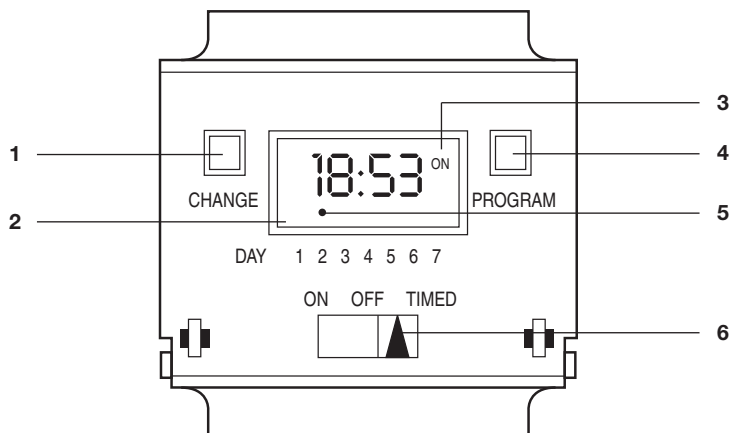

**Fig. 2** Wiring diagram

# 4. Commissioning

## 4.1 Programming the time clock

The time clock will close the valve at the 'OFF' times. At the 'ON' time the time clock will open the valve in a series of opening pulses followed by pause times as set on the internal cycling timer. This avoids the sudden full opening of the valve.



- 1 Override button (also used in conjunction with the program button to program clock and times / days for ON / OFF periods).
- 2 24 hour clock display.
- 3 Output status showing ON or OFF.
- 4 Program button used to program clock and times / days for ON / OFF periods and to review them once set.
- 5 Day indicator 1 = Monday 7 = Sunday
- 6 Slide switch provides continuous ON, continuous OFF or normal program operation.

Fig. 3 Time clock function

### 4.1.1 Battery

The time clock has a factory fitted rechargeable battery. If the time clock is left with its mains power switched off for more than 1 month the display may go blank. In this case switch the mains on, wait 30 mins, and apply reset - see Section 4.1.4.

### 4.1.2 Programming

Only two setting buttons are provided **Change** and **Program**.

During the program mode the **Change** button is used to set days and the hour and minute times. Holding this button down achieves rapid selection of the day, hour and minute times.

During normal operation it is used for changing the output status.

The **Program** button is used to select the clock time and 6 ON/OFF programs and to review them once set. Holding this button down achieves rapid selection of the next program or can be used as a quick exit from program mode.

### 4.1.3 Normal operating mode

In normal operation the display will display the correct day and time with the colon flashing. The output status will be shown by either ON or OFF on the display.

### 4.1.4 To reset display

To clear programs from memory and reset the time, press and hold down both buttons until the display goes blank. Release the buttons and the display will fill with its complete range of characters and then clear to show the clock and the day 1 symbol flashing.

**You are now in the clock setting mode at the beginning of the program sequence.**

### 4.1.5 Program sequence

Setting clock	
Program 1 ON	Program 1 OFF
Program 2 ON	Program 2 OFF
Program 3 ON	Program 3 OFF
Program 4 ON	Program 4 OFF
Program 5 ON	Program 5 OFF
Program 6 ON	Program 6 OFF
Operating mode	

**Note:** If you do not press any button for a minute during programming, the time clock will return automatically to the operating mode.

### 4.1.6 Setting clock (after reset)

**Day setting** - Press **Change** button to advance to the day required.

Day 1 = Monday and Day 7 = Sunday.

**Hour setting** - Press the **Program** button once to select the hour – display shows clock symbol and the hrs digit flashing. Press the **Change** button to advance the hour setting.

**Note:** For rapid hour selection press and hold down **Change** button.

**Minute setting** - Press the **Program** button once to select the minutes - the display shows the clock symbol and minute digits flashing. Press the **Change** button to advance the minutes setting.

**Note:** For rapid minute selection press and hold down **Change** button.

**Press Program button once** - clock is now set and the display shows ready for setting the first ON program time.

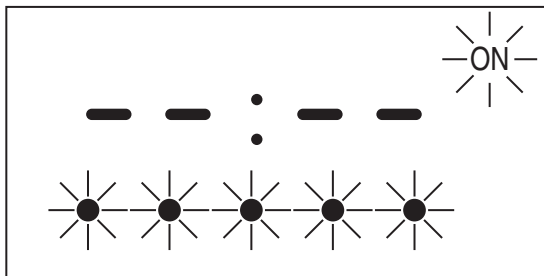

Fig. 4

---

### 4.1.7 To set program ON / OFF times (after clock setting)

Program 1 ON time

Press the **Change** button to advance the day flag to the required day(s) settings, which are:

- 5 days (Weekdays) Mo Tu We Th Fr.
- 2 days (Weekend) Sa Su.
- 7 days (Every day) Mo Tu We Th Fr Sa Su.
- Individual days Starting with Monday through to Sunday.

Once the day option has been selected press the **Program** button once to select the hour time - the display shows hour digits and ON flashing. Press the **Change** button to advance the hour setting.

Press the **Program** button once to select the minute time - the display shows the minute digits and ON flashing. Press the **Change** button to advance the minute setting.

Press the **Program** button once - the first ON time is now set and the display shows ready for the first OFF program time.

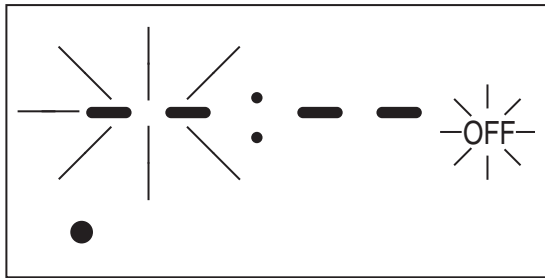

Fig. 5

Now set the hrs and minutes as before. The day(s) selected remains the same.

Repeat these steps to set the remaining 5 ON/OFF times as required. Note: Any unused ON/OFF program should be skipped until the display shows the normal operating mode. Do not program '0's into unused programs.

**IMPORTANT:** After setting a clock time that falls within a program ON period, the unit will not switch ON. Use the override facility to switch the unit ON. After this the unit will operate normally to the programs set.

### 4.1.8 Program review

To fast review the set programs or for quick exit to normal operating mode press and hold the **Program** button.

### 4.1.9 Initiating program mode

This can be initiated any time during the normal operating mode. Press the **Program** button and the clock symbol, day flag, hrs and the minutes symbols on the display will flash - this is review mode. If any change to the program is required, press the **Change** button to initiate the program mode and then follow the steps in Section 4.3.1.

---

#### 4.1.10 Cancelling programs

Any ON/OFF program can be cancelled by clearing its ON and OFF time. Follow Section 4.3.3 and when you reach the ON or OFF program that you wish to cancel, press the **Change** button until the hour digits show --: then press the **Program** button to clear the program. The display will show the hour and minute digits and ON or OFF flashing.

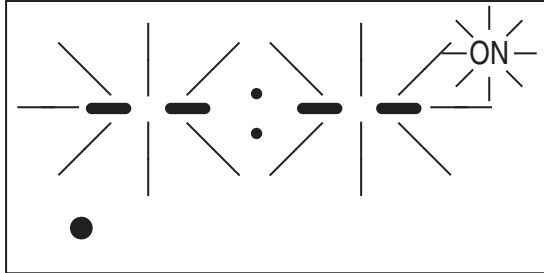

Fig. 6

#### 4.1.11 Self-cancelling override

To change the output status from ON to OFF or vice versa during normal operation press the **Change** button. The output status will change and indicate override is in operation by flashing.

#### 4.1.12 Permanent override

The slide switch provides continuous ON, continuous OFF or normal program operation.

#### 4.1.13 Setting the valve to stay open for several days

A possible requirement is for the valve to be opened on Monday morning, then to stay open until Friday afternoon. An example may be to open the valve at 06.00 on Monday, then close it at 16.00 on Friday. In this case:

- Set the Monday ON time to 06.00.
- Leave the Monday OFF time blank.
- Set the next ON time to Friday, but with the time left blank.
- Set the Friday OFF time to 16.00.

## 4.2 Programming the TV56 cycling timer

The cycling timer is multi-function, and for this application is set so that when powered on, the timer output relay is alternately energised to open the valve for a pulse of a few seconds (**t1** time), followed by a longer pause (**t2** time). The timer continues to cycle until the valve is fully open.

Timer **t1** is the pulse time, **t2** is the pause time.

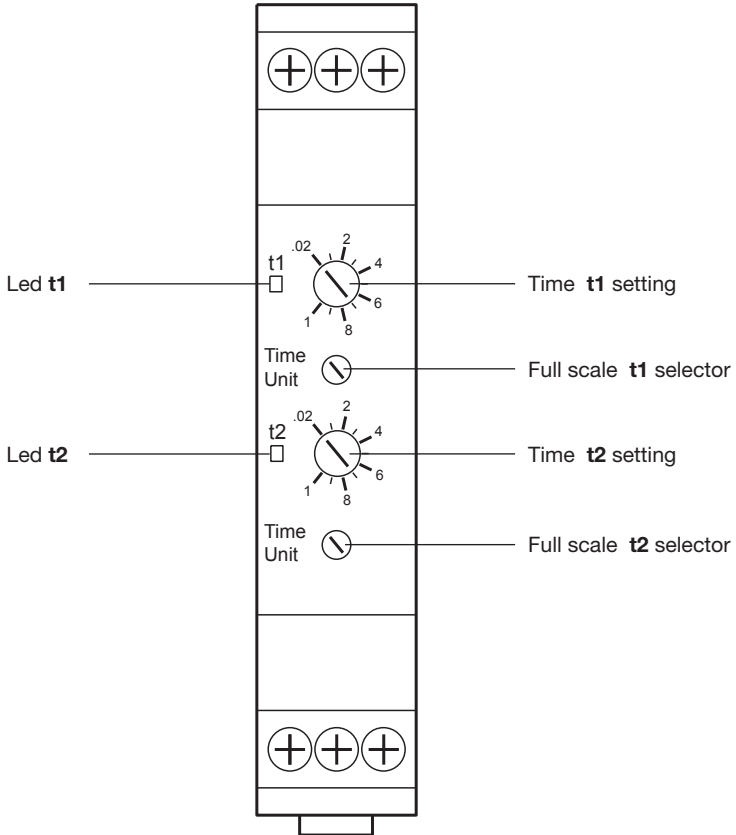

Fig. 7

---

## Example

If the valve has a stroke of 50 mm and the actuator speed is 1 mm/s, the opening time is 50 s of the actuator actually operating.

A suitable pulse time is 3 s, about 17 cycles will be needed to open the valve.

If the total opening time required were 30 minutes then each cycle needs to be about:-

$30 \text{ minutes} \div 17 = 1.8 \text{ minutes}$

Suitable times can then be:

$t_1 = 3 \text{ s}$  and  $t_2 = 1.8 \text{ minutes}$

**In this case  $t_1$**  is set to full scale range 5 seconds, and adjusted to 0.6 on the dial.

**$t_2$**  is set to full scale range 5 minutes, and adjusted to 0.36 on the dial.

The time periods for the pulse and pause can be independently set on the timer from 0.5 seconds to 10 hours. The time scales are adjusted by different positions of the rotary switches on the front of the timer.

