

SV405

Safety Valve

Installation and Maintenance Instructions

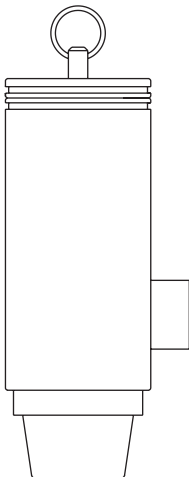

- 1. Safety information*
- 2. Product information*
- 3. Installation*
- 4. Commissioning*
- 5. Testing during use*
- 6. Maintenance*
- 7. Fault finding*

1. Safety information

Safe operation of these products can only be guaranteed if they are properly installed, commissioned, used and maintained by qualified personnel (see Section 1.11) in compliance with the operating instructions. General installation and safety instructions for pipeline and plant construction, as well as the proper use of tools and safety equipment must also be complied with.

1.1 Intended use

Referring to the Installation and Maintenance Instructions, name-plate and Technical Information Sheet, check that the product is suitable for the intended use/application. The product complies with the requirements of the European Pressure Equipment Directive 97/23/EC and fall within Category 4 for Group 2 Gases and carry the CE mark. For compatibility of all other fluids please consult Spirax Sarco.

- i) The product has been specifically designed for use on steam, air and inert industrial gases which are in Group 2 of the Pressure Equipment Directive. The products' use on other fluids may be possible but, if this is contemplated, Spirax Sarco should be contacted to confirm the suitability of the product for the application being considered.
- ii) Check material suitability, pressure and temperature and their maximum and minimum values.
- iii) Determine the correct installation situation and direction of fluid flow.
- iv) Spirax Sarco products are not intended to withstand external stresses that may be induced by any system to which they are fitted. It is the responsibility of the installer to consider these stresses and take adequate precautions to minimise them. Reaction forces must be considered and are the responsibility of the person installing the valve.
- v) Remove protection covers from all connections and protective film from all name-plates, where appropriate, before installation on steam or other high temperature applications.

1.2 Access

Ensure safe access and if necessary a safe working platform (suitably guarded) before attempting to work on the product. Arrange suitable lifting gear if required.

1.3 Lighting

Ensure adequate lighting, particularly where detailed or intricate work is required.

1.4 Hazardous liquids or gases in the pipeline

Consider what is in the pipeline or what may have been in the pipeline at some previous time. Consider: flammable materials, substances hazardous to health, extremes of temperature.

1.5 Hazardous environment around the product

Consider: explosion risk areas, lack of oxygen (e.g. tanks, pits), dangerous gases, extremes of temperature, hot surfaces, fire hazard (e.g. during welding), excessive noise, moving machinery.

1.6 The system

Consider the effect on the complete system of the work proposed. Will any proposed action (e.g. closing isolation valves, electrical isolation) put any other part of the system or any personnel at risk?

Dangers might include isolation of vents or protective devices or the rendering ineffective of controls or alarms. Ensure isolation valves are turned on and off in a gradual way to avoid system shocks.

1.7 Pressure systems

Ensure that any pressure is isolated and safely vented to atmospheric pressure. Do not assume that the system has depressurised even when the pressure gauge indicates zero.

1.8 Temperature

Allow time for temperature to normalise after isolation to avoid danger of burns.

1.9 Tools and consumables

Before starting work ensure that you have suitable tools and/or consumables available. Use only genuine Spirax Sarco replacement parts.

1.10 Protective clothing

Consider whether you and/or others in the vicinity require any protective clothing to protect against the hazards of, for example, chemicals, high/low temperature, radiation, noise, falling objects, and dangers to eyes and face.

1.11 Permits to work

All work must be carried out or be supervised by a suitably competent person. Installation and operating personnel should be trained in the correct use of the product according to the Installation and Maintenance Instructions.

Where a formal 'permit to work' system is in force it must be complied with. Where there is no such system, it is recommended that a responsible person should know what work is going on and, where necessary, arrange to have an assistant whose primary responsibility is safety.

Post 'warning notices' if necessary.

1.12 Handling

Manual handling of large and/or heavy products may present a risk of injury. Lifting, pushing, pulling, carrying or supporting a load by bodily force can cause injury particularly to the back. You are advised to assess the risks taking into account the task, the individual, the load and the working environment and use the appropriate handling method depending on the circumstances of the work being done.

Caution: Never lift the valve by the lifting lever.

1.13 Residual hazards

In normal use the external surface of the product may be very hot. If used at the maximum permitted operating conditions the surface temperature of some products may reach temperatures in excess of 180°C (356°F).

Many products are not self-draining. Take due care when dismantling or removing the product from an installation (refer to 'Maintenance instructions').

1.14 Freezing

Provision must be made to protect products which are not self-draining against frost damage in environments where they may be exposed to temperatures below freezing point.

1.15 Safety information – Product specific

This product should not be dismantled without first releasing the compression on the adjustment spring.

This valve contains PTFE and Viton components. If the valve has been subjected to a temperature exceeding 200°C (392°F), these materials may generate toxic and corrosive hydrofluoric acid and/or hydrogen fluoride. Avoid skin contact and inhalation of any dust or fumes as this compound causes irritation to the eyes, nose, throat and lungs for several hours.

1.16 Disposal

The product is recyclable. No ecological hazard is anticipated with the disposal of this product providing due care is taken. EXCEPT;

PTFE:

- Can only be disposed of by approved methods, not incineration.
- Keep PTFE waste in a separate container, do not mix it with other waste, and consign it to a landfill site.

Viton:

- Can be land filled, when in compliance with National and Local regulations.
- Can be incinerated, but a scrubber must be used to remove Hydrogen Fluoride, which is evolved from the product and with the compliance to National and Local regulations.
- Is insoluble in aquatic media.

1.17 Returning products

Customers and stockists are reminded that under EC Health, Safety and Environment Law, when returning products to Spirax Sarco they must provide information on any hazards and the precautions to be taken due to contamination residues or mechanical damage which may present a health, safety or environmental risk. This information must be provided in writing including Health and Safety data sheets relating to any substances identified as hazardous or potentially hazardous.

2. Product information

2.1 Description

The SV405 is a full nozzle safety valve for steam and air service in non-critical industrial processes requiring low flow, low pressure and temperature.

Available types

The SV405 is available with a brass body, stainless steel nozzle and Viton 'O' ring seat seal as standard.

Applications

The SV405 is designed to protect against overpressure in general process applications such as sterilisers, small compressors and pressure vessels.

Standards and approvals

Seat tightness complies with API standard 527.

This product fully complies with the requirements of the European Pressure Equipment Directive 97/23/EC and carries the **CE** mark.

Note: For further product data see Technical Information Sheet TI-P257-01.

2.2 Sizes and pipe connections

Inlet	Screwed ½" or ¾" BSP taper male BS 21 R
Outlet	Screwed ¾" BSP parallel female BS 21 Rp

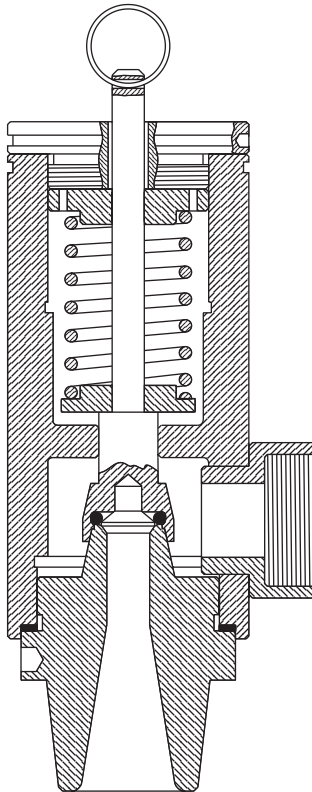
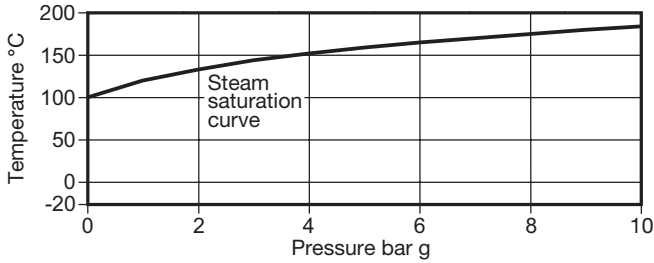

Fig. 1 SV405 safety valve

2.3 Pressure/temperature limits



Body design conditions

Set pressure range	Maximum	10 bar g
	Minimum	1 bar g
Backpressure	Maximum	10% of set pressure
	Minimum	-20°C
Temperature	Viton seat	+200°C
	Overpressure	Steam 10%
Performance data	Gas	10%
	Blowdown limits	Steam, gas 10%
	Derated coefficient of discharge values	Steam, gas 0.78
Tested at a maximum cold hydraulic test pressure of:		20 bar g

2.4 Materials

No.	Part	Material
1	Nozzle	Stainless steel X5 CrNi 18.10
2	Body	Brass EN 121640 CW614N
3	Screw	Stainless steel A2
4	Cap	Brass EN 121640 CW614N
5	Gasket	PTFE
6	Disc holder	Stainless steel X20 CrNi 17
7	'O' ring	Viton FPM 75
10	Spring plate	Brass EN 121640 CW614N
13	Adjusting screw	Brass EN 121640 CW614N
15	Spring	Si - Cr steel EN 1027 - 2 FD Si Cr
16	Pull ring	Spring steel

2.5 Dimensions, orifice, lift and weight (approximate) in mm and kg

A	B	C	Orifice	Lift	Weight
37	49	124	8	3	1.01

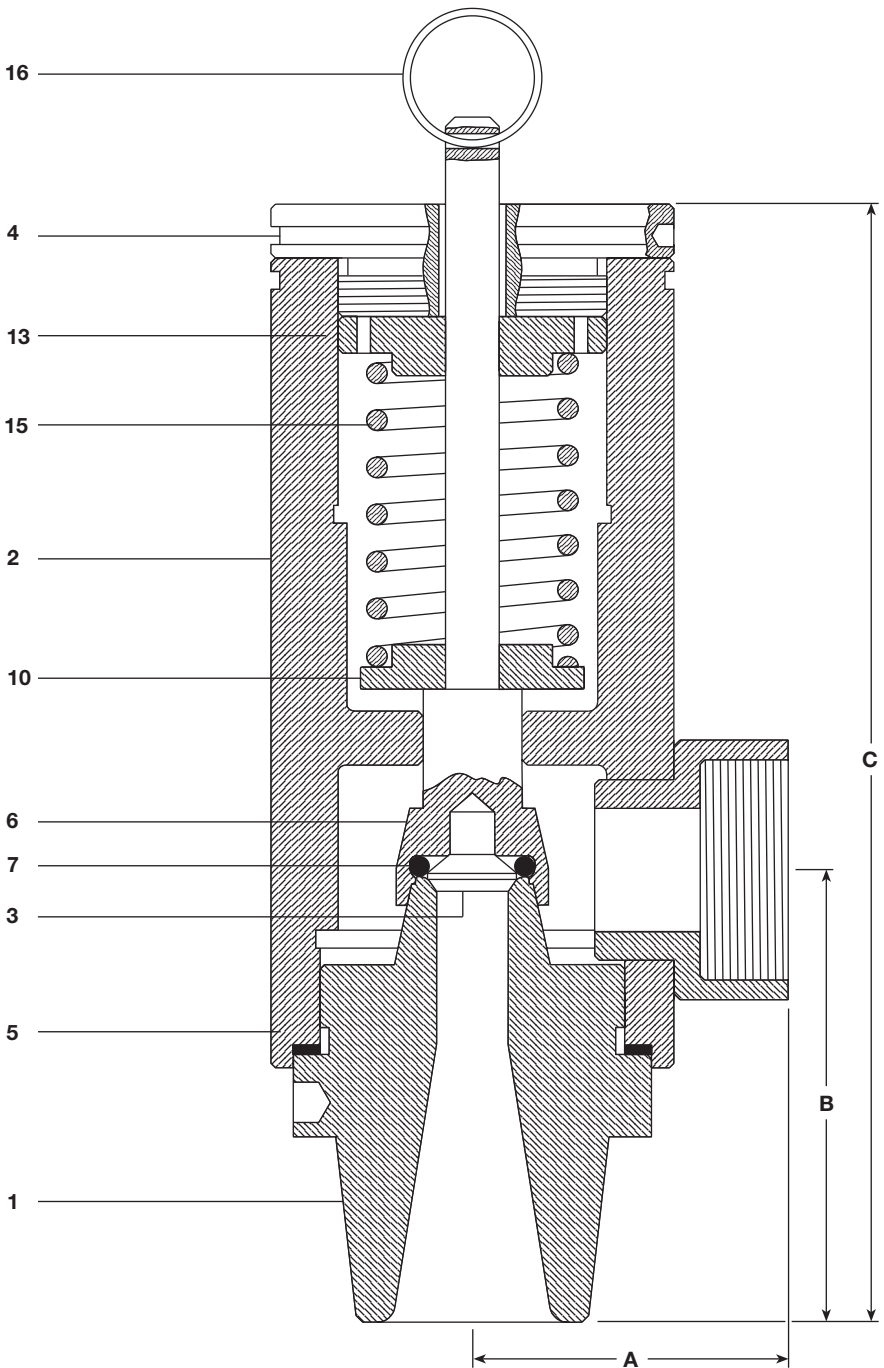

Fig. 2 SV405 parts and dimensions

3. Installation

Note: Before actioning any installation observe the 'Safety information' in Section 1.

Referring to the Installation and Maintenance Instructions, name-plate and Technical Information Sheet, check that the product is suitable for the intended installation. Normally, the valve will be supplied set at the required pressure and sealed.

National standards and local regulations require that the setting of the valve should only be carried out by an authorised/competent person.

Spirax Sarco accepts no responsibility for any valve that has been reset by unauthorised persons.

- 3.1** Ensure that the pipework installation is suitable for the valve.
- 3.2** Ensure that the vessel and pipework are completely free of any foreign matter that may otherwise pass to the valve seat and cause damage, leading to seat leakage. This must be carried out before installing the safety valve.
- 3.3** Remove all packaging and protective flange covers taking care not to allow dirt, dust or other material into the valve.
- 3.4** Visually inspect the valve for any apparent damage. Ensure that all wire and seals are intact.
- 3.5 Inlet piping** - The SV405 safety valve should be installed in a vertical upright position. The inlet piping to the valve should be short and direct from the vessel or equipment being protected. The connection to the vessel should be straight. Sharp corners should be avoided. Should this not be practical, the inlet should be flared out at least one additional pipe diameter.
The pressure drop from the vessel to the safety valve must be less than 3% of the valve set pressure when the valve is flowing. The inlet pipe must not be smaller than the inlet diameter of the valve.
- 3.6 Outlet piping** - Discharge lines from the SV405 shall be at least the same size as the valve outlet and as short and direct as possible. Discharge lines shall prevent condensate from collecting in the discharge side of the valve body and must be directed to a safe discharge area. Care should be taken to ensure thermal expansion of piping and support does not produce strains in the valve. Spring supports are recommended where this may be the case.
- 3.7** Safety valves should be mounted in such a manner as to provide adequate access to the valve.
- 3.8** Always ensure that the backpressure does not exceed 10% of the valve set pressure.
- 3.9 Damage prevention** - Avoid excessive pressure loss at the inlet of a safety valve when it operates as this will cause extremely rapid opening and closing of the valve, observed as chattering or hammering which may result in reduced capacity as well as damage to seating faces and the other parts of the valve and subsequent valve leakage when normal pressure is restored. To overcome this, the valve should be fitted 8-10 pipe diameters downstream of converging or diverging fittings or bends.
- 3.10** Once the valve has been fitted check that there are no leaks from either the inlet or outlet connections.

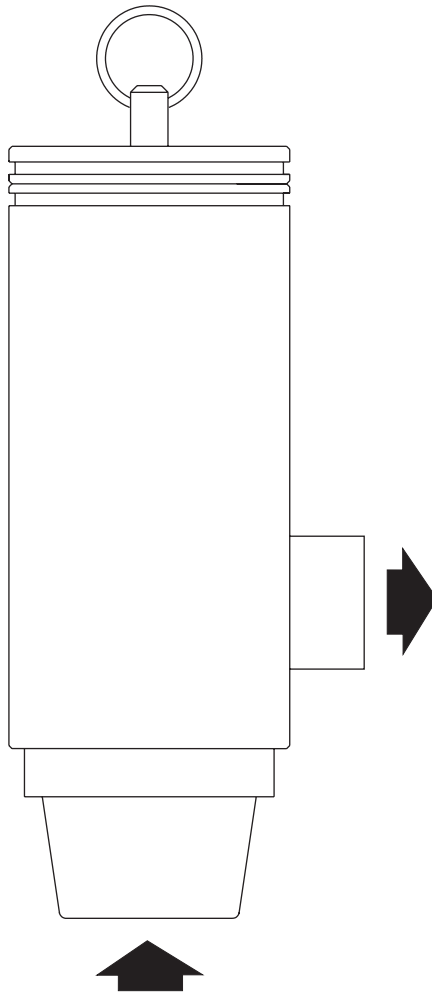

Fig. 3 SV405 safety valve illustrating correct flow and orientation

4. Commissioning

After installation or maintenance ensure that the system is fully functioning. Carry out tests on any alarms or protective devices.

Test the set pressure of the valve by slowly raising the system pressure. Ensure that the valve operates correctly at its specified set pressure as indicated on the name-plate.

Reduce the system pressure to the normal operating pressure and check that the safety valve reseats.

5. Testing during use

It is recommended that the safety valve is tested for correct operation on a regular basis as part of a documented and controlled procedure, the frequency of testing is dependant on the application and system conditions and an appropriate test interval must be decided by the user or relevant insurance company.

6. Maintenance

SV405 Safety valves are 100% tested and then sealed to prevent unauthorised adjustment or repair. Valves should be inspected regularly to assure continued safe operation and long service life. A visual inspection is recommended at two-month intervals while in service, followed by a complete pressure test at least once a year.

For resetting, adjustments or repairs contact Spirax Sarco for the name of competent, authorised personnel who are familiar with the servicing of these safety valves.

7. *Fault finding*

Caution! Removal of the seal wires in an attempt to adjust and/or repair this product by unauthorised or non-qualified persons voids the product guarantee and may cause damage to equipment and serious injury or death.

Problem	Possible cause	Corrective action
Valve does not open at set pressure	Incorrect set pressure	Consult supplier/manufacturer
	Protective flange cover not removed	Remove protective flange cover
	Backpressure too high	Verify the maximum value of backpressure and/or consult supplier/manufacturer
Valve leaking and/or exhibits erratic popping action	Damaged seat	Consult supplier/manufacturer
	Misalignment of parts	Consult supplier/manufacturer
	High backpressure	Check process conditions/consult manufacturer
	Vibrations in pipeline	Identify and eliminate the vibration
Valve does not close, continuously discharging	Operating pressure too close to set pressure	Consult supplier/manufacturer
	Foreign material in seating or guide area	Consult supplier/manufacturer
	Broken or relaxed spring	Consult supplier/manufacturer
Excessive blowdown	High backpressure	Decrease backpressure by increasing outlet pipe discharge area
Chatter/short blowdown	Excessive inlet piping pressure loss	Increase inlet pipe size
	Oversized valve	Review process conditions and valve sizing. Consult supplier/manufacturer
	Variable backpressure exceeds 10% of set pressure	Consult supplier/manufacturer
Valve cannot be lifted manually	Operating pressure is less than 75% of set pressure	Increase the operating pressure to 75% of set pressure or higher

