

DCV4

Disc Check Valve

Installation and Maintenance Instructions

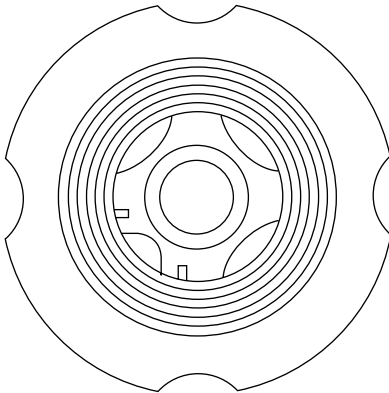

1. *General safety information*
2. *General product information*
3. *Installation*
4. *Commissioning*
5. *Operation*
6. *Maintenance*
7. *Spare parts*

1. General safety information

Safe operation of the unit can only be guaranteed if it is properly installed, commissioned and maintained by a qualified person (see Section 11 of the attached Supplementary Safety Information) in compliance with the operating instructions. General installation and safety instructions for pipeline and plant construction, as well as the proper use of tools and safety equipment must also be complied with.

Isolation

Consider whether closing isolating valves will put any other part of the system or personnel at risk. Dangers might include; isolation of vents and protective devices or alarms. Ensure isolation valves are turned off in a gradual way to avoid system shocks.

Pressure

Before attempting any maintenance consider what is or may have been in the pipeline. Ensure that any pressure is isolated and safely vented to atmospheric pressure before attempting to maintain the product, this is easily achieved by fitting Spirax Sarco depressurisation valves type DV (see separate literature for details). Do not assume that the system is depressurised even when a pressure gauge indicates zero.

Temperature

Allow time for temperature to normalise after isolation to avoid the danger of burns and consider whether protective clothing (including safety glasses) is required.

Viton seat:

If the Viton seat has been subjected to a temperature approaching 315°C (599°F) or higher it may have decomposed and formed hydrofluoric acid. Avoid skin contact and inhalation of any fumes as the acid will cause deep skin burns and damage the respiratory system.

Disposal

These products are recyclable. No ecological hazard is anticipated with the disposal of these products providing due care is taken, EXCEPT:

Viton seat:

- Waste parts can be landfilled, when in compliance with National and Local regulations.
- Parts can be incinerated, but a scrubber must be used to remove Hydrogen Fluoride, which is evolved from the product and with compliance to National and Local regulations.
- Parts are insoluble in aquatic media.

— 2. General product information —

2.1 General description

The DCV4 stainless steel disc check valve is of the wafer pattern designed to be sandwiched between ANSI flanges. It is suitable for use on a wide range of fluids for applications in process lines, hot water systems, steam and condensate systems etc. Face-to-face dimensions conform to EN 558 part 2, series 52.

As standard the valves have a metal-to-metal seat. See Section 2.5 for other options which are available on request.

Note: for additional information see Technical Information Sheet TI-P134-04.

2.2 Sizes and pipe connections

DN15, 20, 25, 40, 50, 80 and 100

Suitable for installation between ANSI 150 or ANSI 300 flanges.

2.3 Optional extras

High temperature springs for temperatures up to 400°C (752°F).

Viton soft seats for oils and gas applications.

EPDM soft seats for water applications.

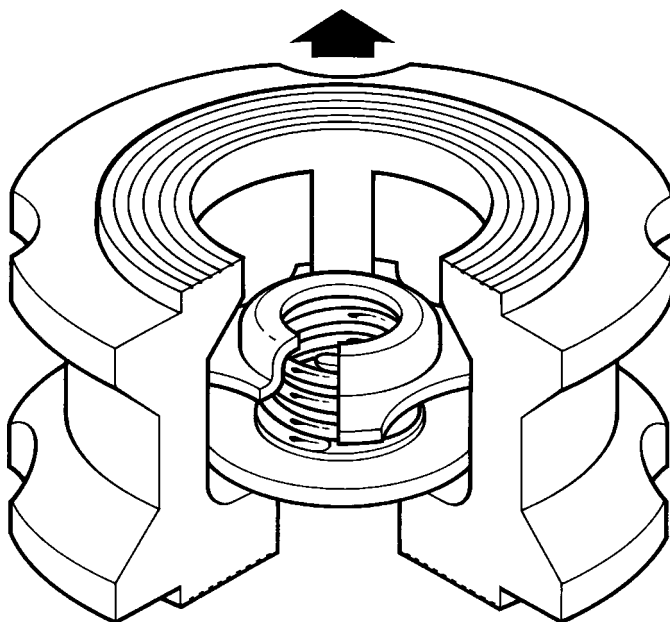

Fig. 1

2.4 Materials

Part	Material
Body	Austenitic stainless steel
Disc	Austenitic stainless steel
Spring retainer	Austenitic stainless steel
Standard spring	Austenitic stainless steel
High temperature spring	Nickel alloy

2.5 Seating options

The valves are stamped to identify the internals fitted:

'N'	- High temperature spring	- Metal disc seat
'W'	- Without spring	- Metal disc seat
'V'	- Standard spring	- Viton disc seat
'E'	- Standard spring	- EPDM disc seat
'WV'	- Without spring	- Viton disc seat
'WE'	- Without spring	- EPDM disc seat
'T'	- Valves tested to DIN 3230 part 3, BO3	

No identification indicates a standard spring with a metal disc.

2.6 Limiting conditions

Body design conditions		ANSI 300	
PMO - Maximum operating pressure		50 bar g	(725 psi g)
TMO - Maximum operating temperature	Standard spring	300°C	(572°F)
	High temperature spring	400°C	(752°F)
	Without spring	400°C	(752°F)
Minimum operating temperature (standard disc)		-29°C	(-20°F)
Temperature limits	Viton seat	-15°C to +250°C	(5°F to 482°F)
	EPDM seat	-29°C to +150°C	(-20°F to 302°F)
Designed for a maximum cold hydraulic test pressure of:		76 bar g	(1102 psi g)

Note: Special testing to allow lower temperature operation can be provided at extra cost. Consult Spirax Sarco.

2.7 Operating range

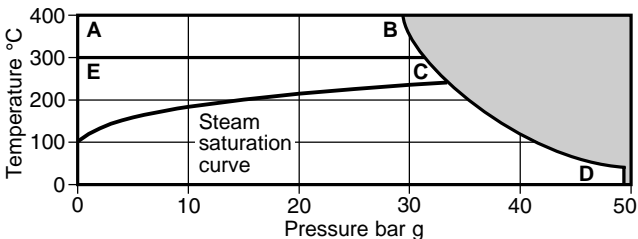

 The product must not be used in this region.

*PMO Maximum operating pressure recommended for saturated steam.

A-B-D High temperature spring and without spring.

E-C-D Standard spring.

3. Installation

Note: Before actioning any installation observe the 'Safety information' in Section 1.

Referring to the Installation and Maintenance Instructions, name-plate and Technical Information Sheet, check that the product is suitable for the intended installation:

- 3.1** Check materials, pressure and temperature and their maximum values. If the maximum operating limit of the product is lower than that of the system in which it is being fitted, ensure that a safety device is included in the system to prevent overpressurisation.
- 3.2** Determine the correct installation situation and the direction of fluid flow.
- 3.3** Remove protective covers from all connections.
- 3.4** Valves must only be installed where 'weld neck' flanges are used. Other flange types may restrict operation.
- 3.5** Disc check valves simply fit between two pipe flanges (see Fig. 2). Standard gaskets are used either side of the valve together with longer bolts or studs. **Note:** flanges, bolts (or studs), nuts and joint gaskets to be provided by the installer. Normal sensible flange bolting practice should be followed eg. torque tightening the bolts in opposite sequence.
- 3.6** The DCV4 can be fitted between ANSI 150 or ANSI 300 flanges. They can be installed in any plane with the exception of DCV's supplied without an internal spring. These must be fitted in a vertical flow line with the flow from bottom-to-top i.e. upward flow (see Fig. 2b). Disc check valves must be fitted in accordance with the direction of the flow arrow on the body, indicating correct fluid flow direction.

Note: Disc check valves are not suitable for use where heavily pulsating flow exists, such as close to a compressor.

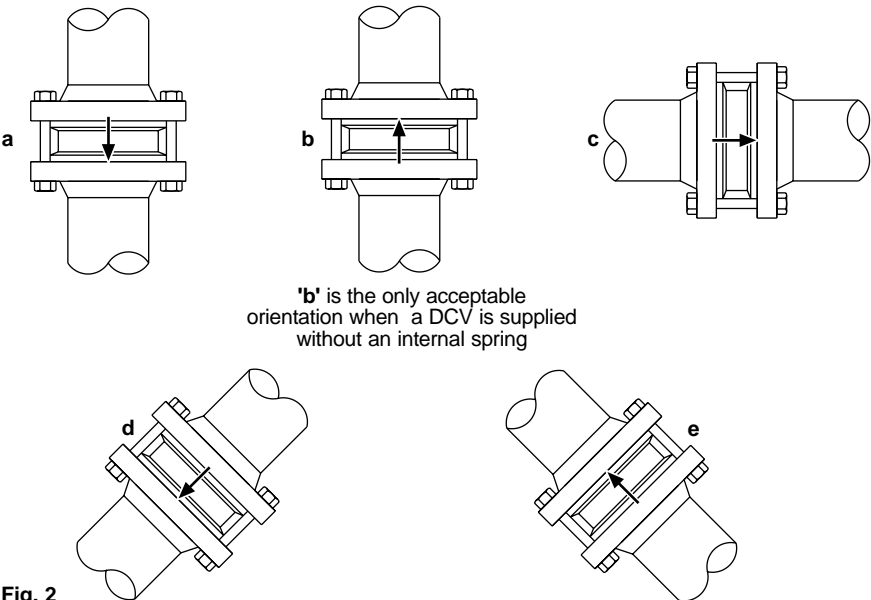

Fig. 2

4. Commissioning

After installation or maintenance ensure that the system is fully functional. Carry out tests on any alarms or protective devices.

5. Operation

Disc check valves are opened by the pressure of the fluid and closed by the spring as soon as the flow ceases and before the reverse flow occurs.

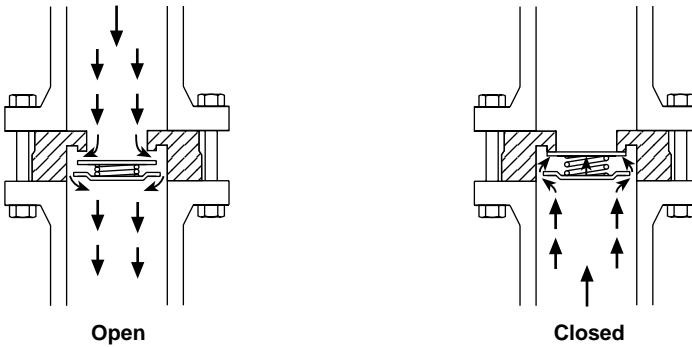

Fig. 3

K_V values

Size	DN15	DN20	DN25	DN40	DN50	DN80	DN100
K _V	4.4	7.5	12	26	39	84	150
For conversion	C _V (UK) = K _V x 0.97		C _V (US) = K _V x 1.17				

Opening pressures in mbar

Differential pressures with zero flow for standard and high temperature springs.

→ Flow direction

Direction	DN15	DN20	DN25	DN40	DN50	DN80	DN100
↑	25	25	25	28	29	31	33
→	22.5	22.5	22.5	24	24.5	25.5	26.5
↓	20	20	20	20	20	20	20

Where lowest opening pressures are required, valves without springs can be installed in vertical pipes with bottom-to-top flow.

Without spring

↑	2.5	2.5	2.5	4	4.5	5.5	6.5
---	-----	-----	-----	---	-----	-----	-----

6. Maintenance

Note: Before actioning any maintenance programme observe the 'Safety information' in Section 1.

This product is non-maintainable.

Note: Great care must be taken if a DCV with a heavy duty spring is taken apart since the strength of the spring can cause the retainer to spring out of the body.

7. Spare parts

There are no spare parts available for this product.

How to order a new product

Example:

1 off Spirax Sarco DN25, DCV4 stainless steel disc check valve for fitting between ANSI 150 flanges.

