

TD151F, TD152F 써모다이내믹 스팀트랩

● 모델

DT151F
DT152F

A, B, C, D

● 사용조건

| | |
|--------------|--------------------------------|
| 몸체설계조건 | ANSI 1500 |
| 최고허용압력(PMA) | 250 bar g |
| 최고허용온도(TMA) | DT151F 425 °C DT152F 560 °C |
| 수압시험압력 | 375 bar g |
| 최저작동압력 | 10 bar g |
| 최대허용배압(PMOB) | 1차 압력의 50 % |

● 운전조건범위

모델 TD151F

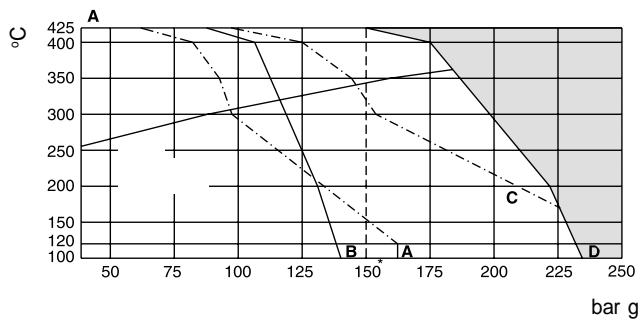

모델 TD152F

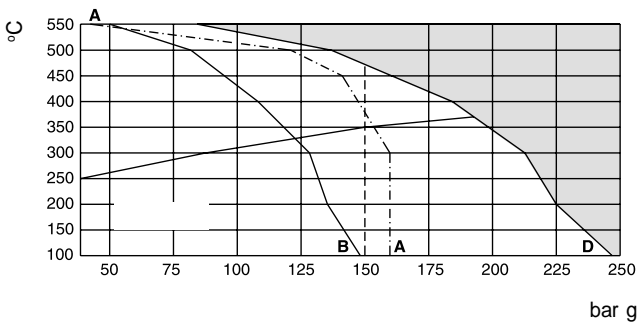

가

* PMO -

- A - A PN160
- A - B ANSI 900
- A - C PN250
- A - D ANSI 1500

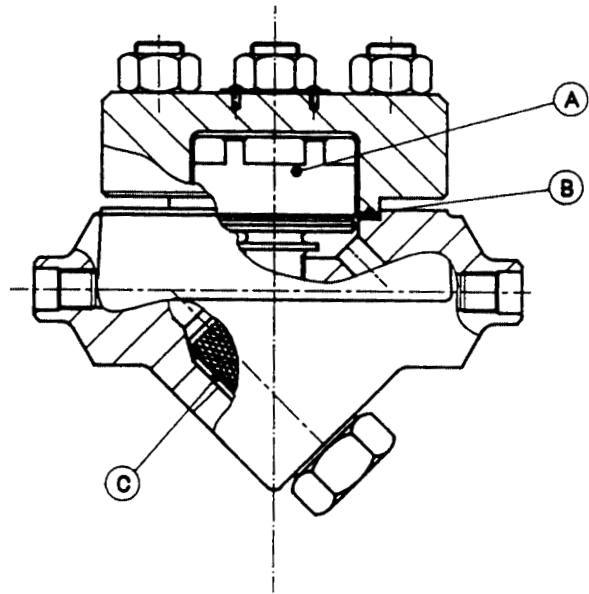

● 구경 및 배관연결 방법

½", ¾", 1", 1½" (ANSI B16 · 25)
(ANSI B16 · 11), NPT
DN15, 20, 25, 40 ANSI 600, 900, 1500

● 재 질

| 부품명 | 재질 | |
|-----------------|-----------------|-----------------------------|
| Body | DT151F | Carbon Steel ASTM A 105 |
| | DT152F | Alloy Steel ASTM A 182 F 22 |
| Cover | DT151F | Carbon Steel ASTM A 105 |
| | DT152F | Alloy Steel ASTM A 182F 22 |
| Cover Gasket | Stainless Steel | AISI 304 |
| Cover Studs | Steel | ASTM A 193 B 16 |
| Cover nuts | Steel | ASTM A 194 gr. 8 |
| Internal Trim | Stainless Steel | AISI S.400 |
| Strainer Screen | Stainless Steel | AISI 316 |

TD151F, TD152F 써모다이나믹 스팀트랩

TI-P068-K001
ST Issue 3
(KR 9909)

● 용량

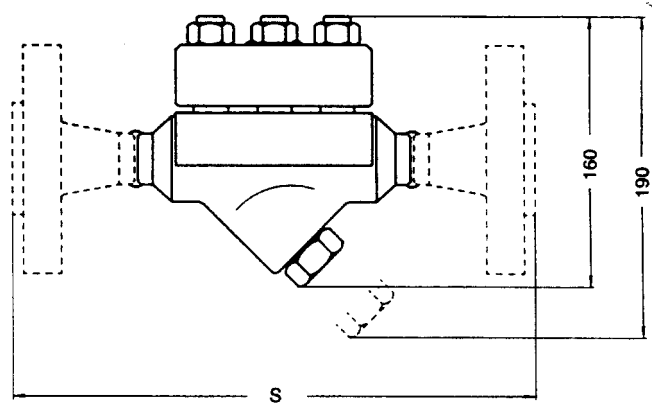
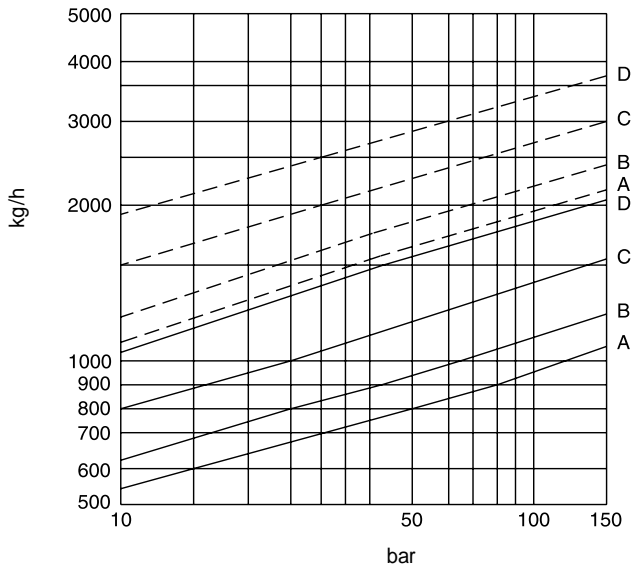

● 치수(mm)

| DN | 1/2" | | 3/4" | | 1" | | 1 1/2" | |
|------------------|------|------|------|------|-----|------|--------|------|
| | s | kg | s | kg | s | kg | s | kg |
| 나사식 용접식 | 160 | 7 | 160 | 7 | 160 | 7 | 160 | 7 |
| PN 100/160 | 255 | 9 | 268 | 11 | 280 | 12 | 288 | 14 |
| PN 250 | 285 | 12 | 288 | 13 | 295 | 14 | 325 | 19 |
| ANSI 600 | 280 | 9.8 | 290 | 10.6 | 300 | 11.6 | 316 | 16 |
| ANSI 900/1500 | 297 | 11.4 | 315 | 13.4 | 323 | 15.2 | 342 | 19.8 |

● 설치방법

24

● 정비부품 가

정비부품명세

| | |
|-----------------------------|-----|
| Set of Internals | A-B |
| Screen Assembly | C |
| Set of Cover Gaskets(3 off) | B |

● 정비방법

가

스트레나의 청소