



Cert. No. LRQ 0963008

ISO 9001

S20SS 기수분리기

● 개요

S20SS
, 가

● 사용조건

최고허용압력(PMA)	25 bar g
최고허용온도(TMA)	300 °C
수압시험압력	38 bar g

● 구경

DN15~200

● 배관연결방법

BSP : DN15~50
KS10, KS20, ANSI150,
ANSI300 : DN15~200

● 재질

부품명	재질	규격
Body	Stainless steel	KS STS316L

● 치수(mm) 및 무게(kg)

구경 DN	A	A1 나사식 플랜지식	B	C	D	E	G	F (플랜지식)	무게
15	120	160	125	300	77		½"	½"	4.1
20	136	200	124	324	89		½"	½"	5.9
25	160	220	131	354	114		½"	½"	8.9
32	190	240	162	420	140		½"	½"	14.1
40	220	280	175	495	165		½"	1"	18.7
50	220	290	209	561	165		½"	1"	21.8
65		350	246	655	216	163	¾"	1"	37
80		410	305	742	267	160	¾"	2"	60
100		475	363	830	319	160	¾"	2"	85
125		560	288	843	356	284	¾"	2"	128
150		650	305	950	406	218	¾"	2"	195
200		840	400	1215	508	273	¾"	2"	300

(*) 별도의 Leg type 공급가능

● 설치방법

● 용량표

TI - S33 - 06

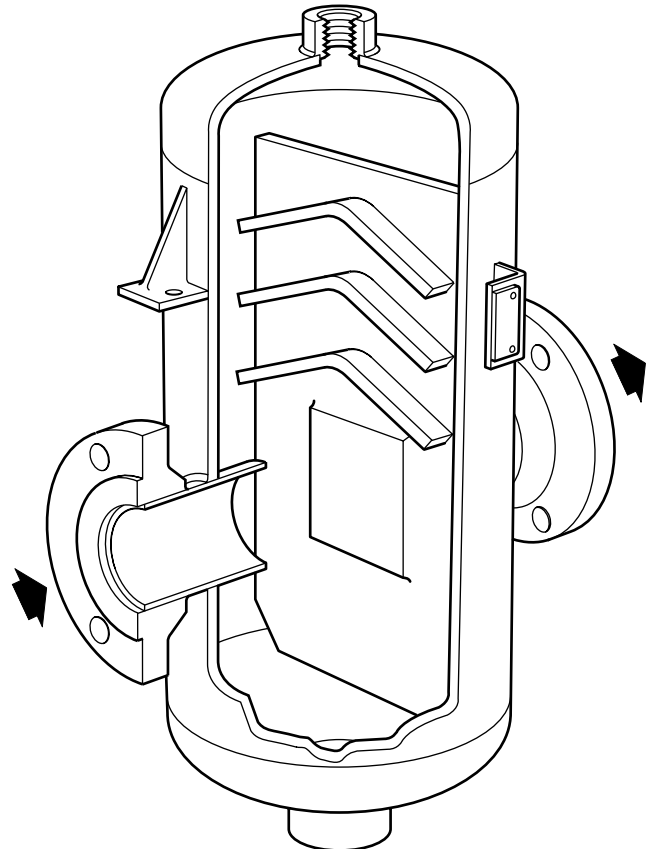

DN15 ~ 50

G 에어벤트

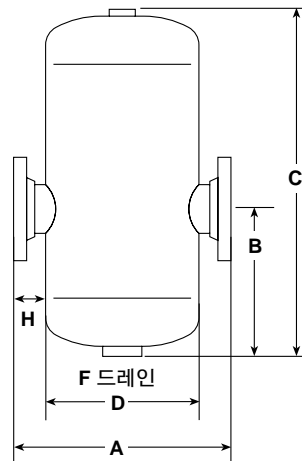

DN65 ~ 250

G 에어벤트

