

spirax sarco

SJT Steam Jet Thermocompressor

Description

Jet Compressors can be utilized in a number of applications for steam circulation and increasing lower pressures to be functional.

Jet Compressors are generally referred as thermocompressors when steam is both motive and suction medium, or if the aim is to recover latent heat content of low pressure steam to be utilized elsewhere in a process.

The Spirax Sarco thermocompressors are a specific type of ejector in which steam under pressure (motive) is used to entrain steam that is at a lower pressure (suction). Within the body of the ejector, the motive steam and suction steam become mixed and are subsequently discharged at an intermediate pressure.

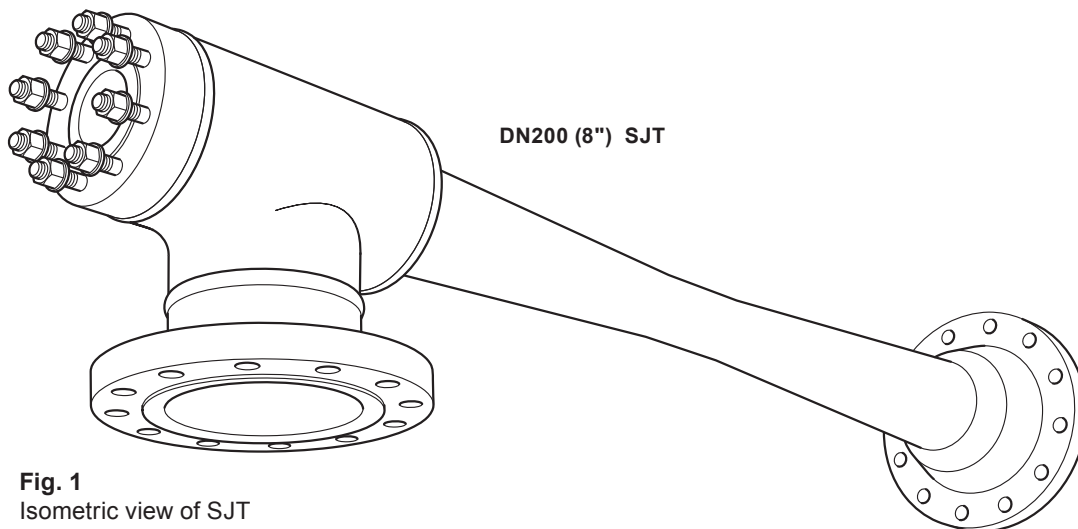

Fig. 1
Isometric view of SJT

Features & Benefits

The SJT Steam Jet Thermocompressors features and benefits include:

- Simple construction
- Available in alternative machined materials for increased abrasion resistance.
- Compact design and comparatively lightweight which enables overhead installations.
- Low capital cost and operating costs.
- No moving or rotating parts with minimal maintenance and therefore the units can be installed in remote or with limited accessibility.
- No specialist maintenance experience required.
- Discharge steam is oil free, no lubrication contamination.
- Suitable for hazardous areas, no explosion proof motors required.
- Recirculation without loss of heat or energy through reducing valves.
- Insulation available.

SJT Construction and Operation

SJT's typically include the following main design features:-

- Body
- Nozzle
- Diffuser
- Spindle
- Actuator to move spindle (option for variable type SJT)

SJTs can be supplied in alternative materials to suit various application conditions.

High pressure motive steam enters the SJT Steam Jet Thermocompressor and passes through the nozzle where the high pressure steam energy is converted into kinetic energy. On leaving the nozzle at high velocity, the steam enters the suction chamber where it is brought in contact with the suction steam. There is then an exchange of momentum between the motive and suction steam, resulting in an acceleration of the suction steam, giving rise to their subsequent entrainment. A uniform mixture results at the narrowest part of the diffuser (called the throat) and finally the reconversion of the velocity energy into pressure energy occurs in the diverging section of the diffuser.

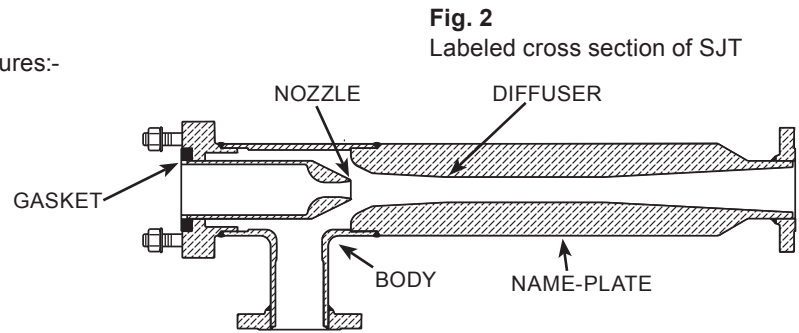

Types of Thermocompressor

Fixed nozzle type

This type of compressor has no regulating spindle. An element of control is achievable by throttling the motive steam pressure via a separate valve upstream of the SJT (See Fig. 3).

Typically the fixed nozzle is used when operating loads are stable.

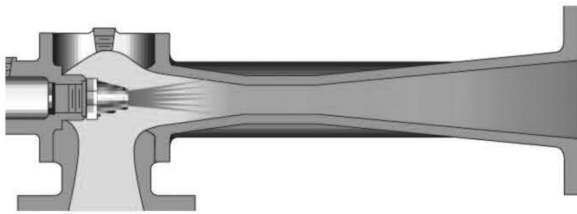

Fig. 3 Cross section of fixed nozzle type SJT
Fixed Orifice (loads stable, less than 10% variation)

Variable Area

This compressor includes a motive steam regulating spindle to vary the cross sectional area of the motive steam nozzle (See Fig. 4). It varies the area through which the steam is flowing. This approach maximizes the energy per lb of motive steam that is available at the nozzle to do the work.

Typically the variable area SJT is used when either; motive, or suction, or discharge steam varies in condition, and the specific flow or pressure of the discharge is required.

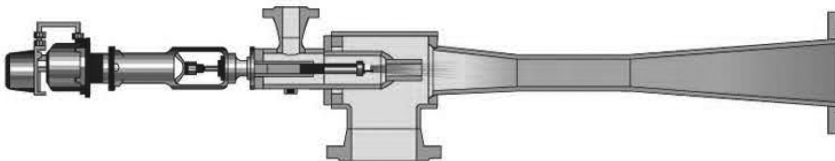
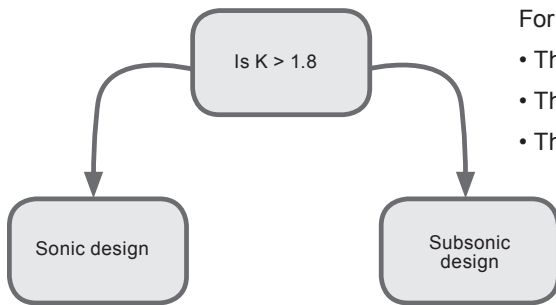

Fig. 4 Cross section of variable area SJT
Variable Area (Loads/Conditions vary)

Performance - Critical or Noncritical

Thermocompressors can be categorized as either critical or noncritical based on the compression ratio. In order to determine what type of design the SJT will be, the following compression calculation is completed;

$$\text{Compression ratio (K)} = \frac{\text{Discharge pressure (P}_d\text{)}}{\text{Suction pressure (P}_s\text{)}}$$



For Example:

- The discharge pressure = 36.3 psig (2.5 bar g) = 51.0 psi a (3.513 bar a)
- The suction pressure = 17.4 psig (1.2 bar g) = 32.1 psi a (2.213 bar a)
- The compression ratio (K) = 51.0 psig (3.513 bar g)/32.1 psig (2.213 barg) = 1.59

If the steam velocity in the diffuser throat is sonic, the design is defined as critical. Sonic velocity exists when the compression ratio (discharge pressure/suction pressure) is equal to or greater than 1.8 to 1.

The ratio value changes as a function of the ratio of the specific heat of the motive and suction steam.

Unless motive pressure and discharge pressure are decreased proportionally with a critical design, a reduction in motive steam pressure will result in a sudden increase to suction pressure. The relationship between motive pressure and discharge pressure depends on the specific characteristics of the individual design.

Sonic designs	Subsonic designs
Compression ratio (K) greater than 1.8	Compression ratio (K) is less than 1.8
Compression ratio (K) greater than 1.8	With a subsonic design, the motive (HP) steam flowrate can be varied to 'save' steam when process conditions become more favorable.
The Suction (LP) steam flowrate can operate with full turndown (100% to 0%)	The Suction (LP) steam flowrate can operate with full turndown (100% to 0%).
	Spirax Sarco offer a special design called a 'Variable Orifice' thermocompressor which has integrated motive steam control.

Control options

The schematic below illustrates every possible control option that could be used to control an SJT Steam Jet Thermocompressor.

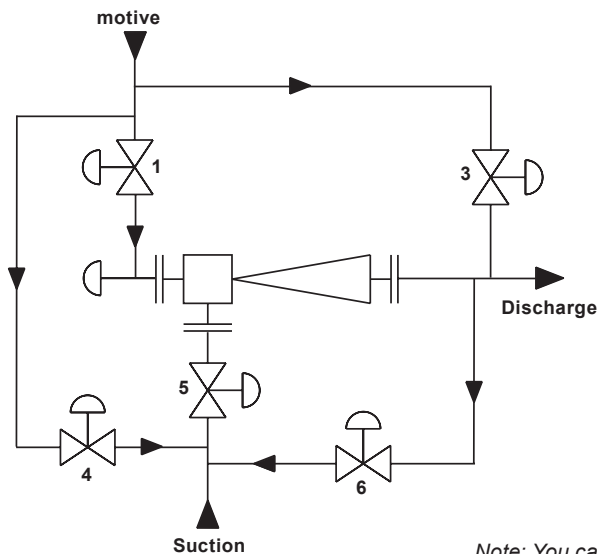

Subsonic designs:

Option 1	Can be used to control the motive (HP) steam flow from 100% to 80%
Option 2	Can be used to control the motive (HP) steam flow from 100% to 35%
Option 3	Can be used to bypass additional steam to the discharge. Options 4 or 5 or 6 are occasionally used to maintain the suction (LP) pressure

Sonic designs:

Option 3	Can be used to bypass additional steam to the discharge
Option 4 or 5	Are occasionally used instead of option 6
Option 6	Is usually used to maintain the Suction (LP) pressure (if required)

Fig. 5
Control options for SJT

Note: You cannot choose Options 1 or 2 if the SJT Steam Jet Thermocompressor is 'Sonic'

Most applications will only use one of the options. Some applications do not require any control. An SJT Steam Jet Thermocompressor will always balance itself to the system pressures.

Variable orifice SJT Steam Jet Thermocompressors

Spirax Sarco offers several types of Thermocompressor. The first is the fixed nozzle type where control is achievable by throttling the motive steam pressure via a separate valve upstream of the SJT Steam Jet Thermocompressor (See Control Option 1, previous page, for subsonic units).

The other type relies on a motive steam regulating spindle to vary the cross sectional area of the motive steam nozzle (Control Option 2, previous page). Unlike a throttling valve positioned upstream, the regulating spindle does not reduce the motive steam pressure, it simply varies the area through which the steam is flowing, maximizing the utilization of energy in the motive steam.

SJT Steam Jet Thermocompressors utilizing a motive steam regulating spindle are often referred to as Variable Orifice Ejectors. The spindle is operated automatically.

Selection

Variable orifice SJT Steam Jet Thermocompressors should be specified in cases where the suction load, suction pressure or discharge pressure are continually varying, and it is necessary to control one or more of these process parameters as quickly as possible.

For cases which involve large variations in load, it is sometimes more cost effective to use several various sized units connected in parallel, than to have one large controlled unit. It may also be necessary to install a bypass valve in some applications.

Defining the parameters to be controlled (E.g. pressure, flow, etc.) Will determine the optimum solution for the application, and best return on investment. Spirax Sarco can provide assistance in selecting the right solution for your needs.

Typical Applications

The following lists the applications where SJT Steam Jet Thermocompressors can be installed, typically for circulating and boosting low pressure steam which would normally go to waste:

Applications	Industries
Drum dryers	Paper and Board Industries
Flash evaporators	Desalination
Condensate receivers	Chemical, Petro-chemical, Oil and Power Generation
Vulcanisers	Rubber Industry
Single and Multi-stage effect evaporators	Food, Dairy, Pharmaceutical & Chemical Industries
Wort vessels	Brewing Industry
Exhaust steam lines	Most Process Industries
Blanching machines	Food Industry

How to order

Please use the following format to specify a Thermocompressor and include a datasheet detailing all values.

Example: 1 off Spirax Sarco Size 6 SJT150CS Steam Jet Thermocompressor having ASME 300 RF slip on flange connections.

Note: Attach the SJT Datasheet to the order.

Datasheet generated by the online software program

A typical example is illustrated below:

Spirax Sarco SJT Steam Jet Thermocompressor Datasheet

1	Client:	Spirax-Sarco Inc.	Client Project Ref:	
2	Client's Ref:		Plant Location:	
3	Spirax Ref:	SJT Example/SJT00824	Name-plate Tag No.	
4	Description:	Size 6 Steam Jet Thermocompressor	No. OFF:	1
5	Unit Ref:	SJT150CS4F0	Operation:	
6	Drawing No:	DE-SJT00824-1	Serial No:	
7	Unit Body Size:	6		

8 MOTIVE CONDITIONS			MATERIALS OF CONSTRUCTION			
9	Pressure (psig)	293.92	Main body	Carbon Steel		
10	Temperature (°F)	419.0	Nozzle	Stainless Steel		
11	Flowrate (lb/hr)	5689	Diffuser	Carbon Steel		
12			Flanges	Carbon Steel		
13	SUCTION CONDITIONS		Gaskets	Spirax Sarco to select		
14	Pressure (psig)	1.47	Bolts	Carbon Steel (if applicable)		
15	Temperature (°F)	216.9	Name-plate	Stainless Steel		
16	Flowrate (lb/hr)	3308				
17			MECHANICAL DESIGN	Motive	Suction/Discharge	
18	DISCHARGE CONDITIONS			Side	Side	
19	Pressure (psig)	22.04	Max Design Pressure	22.04	22.04	(psig)
20	Temperature (°F)	294.1	Max Design Temp	428	428	(°F)
21	Flowrate (lb/hr)	8996	Internal Corrosion Allowance	38.1	38.1	(in)
22	DIFFUSER IS SONIC		Mechanical Design Code	ASME B31.3		
23			Welding Standard	ASME IX		
24			External Surface Finish	High Temp Silicone Aluminum		
25			Weight	TBC (lb)		
26						

27 DIMENSIONS		CONNECTIONS DETAILS		Size	Rating
28	A - 9.65 in	Motive Steam (A)		2 ½	300 lb
29	B - 11.42 in	Suction Steam (B)		6	300 lb
30	C - 54.13 in	Discharge Steam (C)		6	300 lb
31	D - 65.55 in	Flange Type		ASME B 16.5 Slip-On	

32 **GA DRAWING**

33

34

35

36

37

38

39

40

41

42

43

NOTE: Confirmed dimensions to be issued shortly after order placement