

## BSA3HP

### Bellows Sealed High Pressure Stop Valve

Installation and Maintenance Instructions

---

---

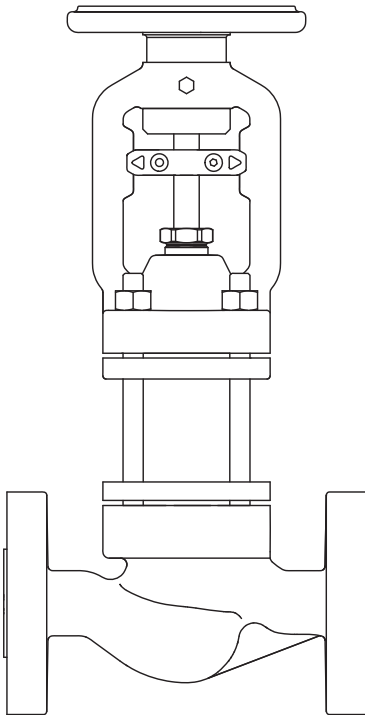

1. Safety information
2. General product information
3. Installation
4. Commissioning
5. Operation
6. Maintenance
7. Spare parts



# 1. Safety information

Safe operation of these products can only be guaranteed if they are properly installed, commissioned, used and maintained by qualified personnel (see Section 1.11) in compliance with the operating instructions. General installation and safety instructions for pipeline and plant construction, as well as the proper use of tools and safety equipment must also be complied with.

## 1.1 Intended use

Referring to the Installation and Maintenance Instructions, product markings and Technical Information Sheet, check that the product is suitable for the intended use/application.

The products listed below comply with the requirements of the European Pressure Equipment Directive and carries the  mark when so required.

The products fall within the following Pressure Equipment Directive categories:

BSA 3HP Size	Group 1 Gases	Group 2 Gases	Group 1 Liquids	Group 2 Liquids
DN15 - DN25	SEP	SEP	SEP	SEP
DN32	2	SEP	2	SEP
DN40 - DN100	2	1	2	SEP

- i) These products have been specifically designed for use on steam, air or condensate/water, which is in Group 2 of the above mentioned Pressure Equipment Directive. The products' use on other fluids may be possible but, if this is contemplated, Spirax Sarco should be contacted to confirm the suitability of the product for the application being considered.
- ii) Check material suitability, pressure and temperature and their maximum and minimum values. If the maximum operating limits of the product are lower than those of the system in which it is being fitted, or if malfunction of the product could result in a dangerous overpressure or overtemperature occurrence, ensure a safety device is included in the system to prevent such over-limit situations.
- iii) Determine the correct installation situation and direction of fluid flow.
- iv) Spirax Sarco products are not intended to withstand external stresses that may be induced by any system to which they are fitted. It is the responsibility of the installer to consider these stresses and take adequate precautions to minimise them.
- v) Remove protection covers from all connections, where appropriate, before installation on steam or other high temperature applications.

## 1.2 Access

Ensure safe access and if necessary a safe working platform (suitably guarded) before attempting to work on the product. Arrange suitable lifting gear if required.

### **1.3 Lighting**

Ensure adequate lighting, particularly where detailed or intricate work is required.

### **1.4 Hazardous liquids or gases in the pipeline**

Consider what is in the pipeline or what may have been in the pipeline at some previous time. Consider: flammable materials, substances hazardous to health, extremes of temperature.

### **1.5 Hazardous environment around the product**

Consider: explosion risk areas, lack of oxygen (e.g. tanks, pits), dangerous gases, extremes of temperature, hot surfaces, fire hazard (e.g. during welding), excessive noise, moving machinery.

### **1.6 The system**

Consider the effect on the complete system of the work proposed. Will any proposed action (e.g. closing isolation valves, electrical isolation) put any other part of the system or any personnel at risk?

Dangers might include isolation of vents or protective devices or the rendering ineffective of controls or alarms. Ensure isolation valves are opened and closed progressively to avoid system shocks.

### **1.7 Pressure systems**

Ensure that any pressure is isolated and safely vented to atmospheric pressure. Consider double isolation (double block and bleed) and the locking or labelling of closed valves. Do not assume that the system has depressurised even when the pressure gauge indicates zero.

### **1.8 Temperature**

Allow time for temperature to normalise after isolation to avoid the danger of burns.

### **1.9 Tools and consumables**

Before starting work ensure that you have suitable tools and/or consumables available. Use only genuine Spirax Sarco replacement parts.

### **1.10 Protective clothing**

Consider whether you and/or others in the vicinity require any protective clothing to protect against the hazards of, for example, chemicals, high /low temperature, radiation, noise, falling objects, and dangers to eyes and face.

## **1.11 Permits to work**

All work must be carried out or be supervised by a suitably competent person. Installation and operating personnel should be trained in the correct use of the product according to the Installation and Maintenance Instructions.

Where a formal 'permit to work' system is in force it must be complied with. Where there is no such system, it is recommended that a responsible person should know what work is going on and, where necessary, arrange to have an assistant whose primary responsibility is safety.

Post 'warning notices' if necessary.

## **1.12 Handling**

Manual handling of large and/or heavy products may present a risk of injury. Lifting, pushing, pulling, carrying or supporting a load by bodily force can cause injury particularly to the back. You are advised to assess the risks taking into account the task, the individual, the load and the working environment and use the appropriate handling method depending on the circumstances of the work being done.

## **1.13 Residual hazards**

In normal use the external surface of the product may be very hot. If used at the maximum permitted operating conditions the surface temperature may reach temperatures in excess of 400 °C (752 °F).

Many products are not self-draining. Take due care when dismantling or removing the product from an installation (refer to 'Maintenance instructions').

## **1.14 Freezing**

Provision must be made to protect products which are not self-draining against frost damage in environments where they may be exposed to temperatures below freezing point.

## **1.15 Disposal**

Unless otherwise stated in the Installation and Maintenance Instructions, this product is recyclable and no ecological hazard is anticipated with its disposal providing due care is taken.

## **1.16 Returning products**

Customers and stockists are reminded that under EC Health, Safety and Environment Law, when returning products to Spirax Sarco they must provide information on any hazards and the precautions to be taken due to contamination residues or mechanical damage which may present a health, safety or environmental risk. This information must be provided in writing including Health and Safety data sheets relating to any substances identified as hazardous or potentially hazardous.

# 2. General product information

## 2.1 General description

The BSA3HP is a carbon steel bodied high pressure in-line non throttling stop valve, having a multi-ply bellows and unbalanced or balanced options. These valves are rated to EN 1092 PN100 or ASME class 600 for use with both saturated and superheated steam applications and a range of other industrial gases and fluids.

### Range and options

Size	Unbalanced		Balanced	
	PN100	Class 600	PN100	Class 600
DN15 - DN50	●	●		
DN65 - DN100	●	●	●	●

### Standards

The product fully complies with the requirements of the European Pressure Equipment Directive and carries the  mark when so required.

### Certification

The BSA3HP is available with certification to EN 10204 3.1.

**Note:** All certification/inspection requirements must be stated at the time of order placement.

**Note:** For further product data see the following Technical Information sheet TI-P184-15.

## 2.2 Sizes and pipe connections

DN15, DN20, DN25, DN32, DN40, DN50, DN65, DN80 and DN100

Flanged EN 1092 PN100 and ½", ¾", 1", 1¼", 1½", 2", 2½", 3" and 4"

Flanged ASME class 600

## 2.3 Seat leakage

Plug to seat shut-off conforms to EN 12266-1 Rate A leakage.

## 2.4 K<sub>v</sub> values

Size	DN15 (½")	DN20 (¾")	DN25 (1")	DN32 (1¼")	DN40 (1½")	DN50 (2")	DN65 (2½")	DN80 (3")	DN100 (4")
K <sub>v</sub>	3.1	7.6	8.6	24	28	36.8	80	86	134

For conversion:

$C_V$  (UK) =  $K_V \times 0.963$

$C_V$  (US) =  $K_V \times 1.156$

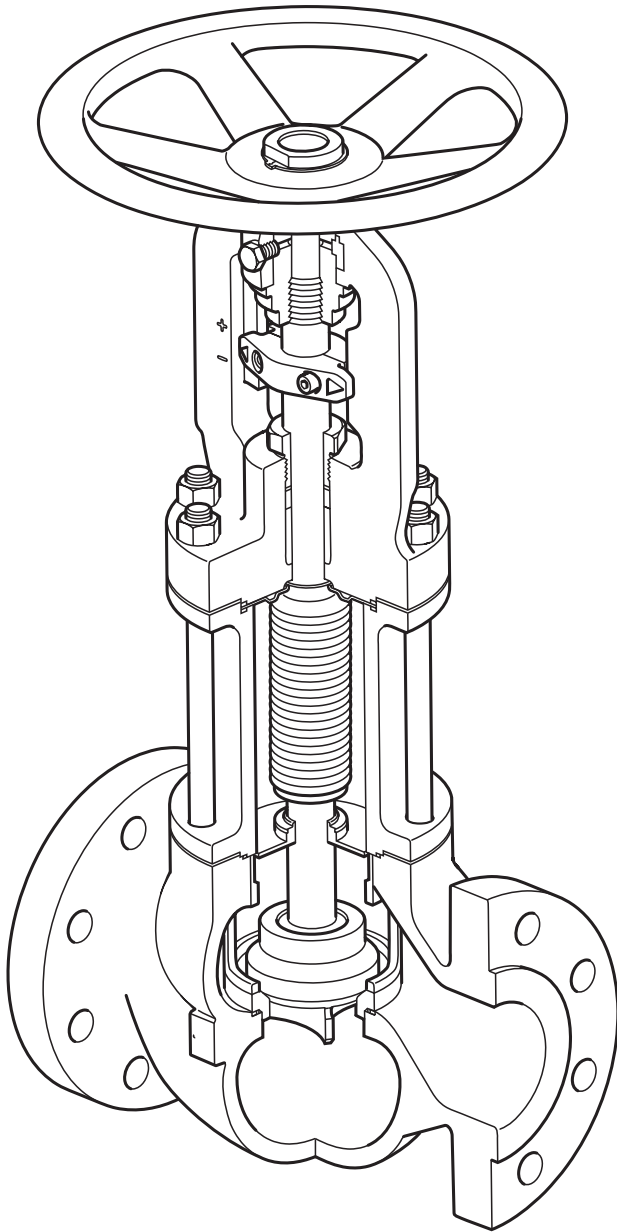
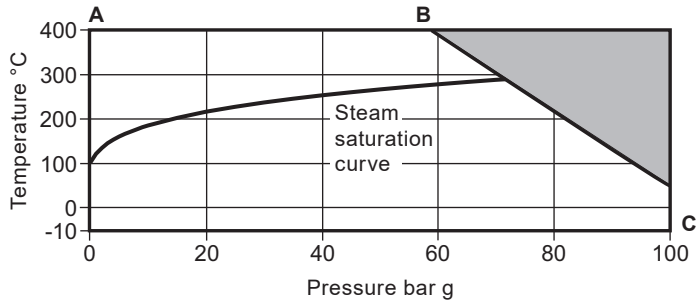

**Fig. 1 BSA3HP bellows sealed high pressure stop valve**

## 2.5 Pressure / temperature limits (ISO 6552)

### PN100

A-B-C



The product **must not** be used in this region or beyond the parameter of the PMA or TMA of the relative end connection.

Body design condition	PN100
PMA Maximum allowable pressure	100 bar g @ 50 °C
TMA Maximum allowable temperature	400 °C @ 59.5 bar g
Minimum allowable temperature	-10 °C
PMO Maximum operating pressure for saturated steam service	70.5 bar g @ 287.3 °C
TMO Maximum operating temperature	400 °C @ 59.5 bar g
Minimum operating temperature	-10 °C
Designed for a maximum cold hydraulic test pressure of:	150 bar g



## Class 600

A-D-E

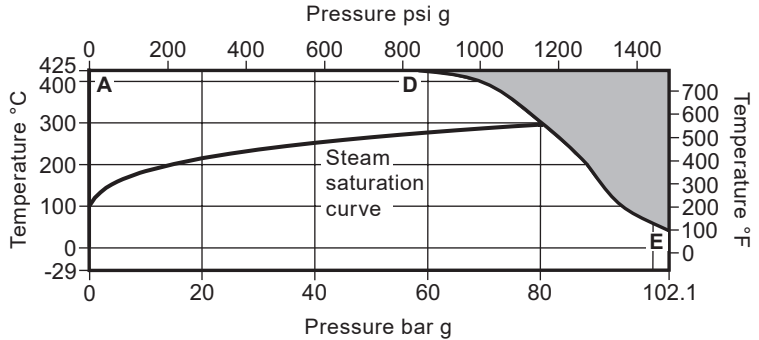

The product **must not** be used in this region or beyond the parameter of the PMA or TMA of the relative end connection.

Body design condition	Class 600		
PMA	Maximum allowable pressure	102.1 bar g @ 38 °C	1481psi g @ 100 °F
TMA	Maximum allowable temperature	425 °C @ 57.5 bar g	797 °F @ 834 psi g
	Minimum allowable temperature	-29 °C	-20 °F
PMO	Maximum operating pressure for saturated steam service	79.8 bar g @ 295.8 °C	1156 psi g @ 564.4 °F
TMO	Maximum operating temperature	425 °C @ 57.5 bar g	797 °F @ 834 psi g
	Minimum operating temperature	-29 °C	-20 °F
	Designed for a maximum cold hydraulic test pressure of:	154 bar g	2233 psi g

# 3. Installation

**Note:**

**Before actioning any installation observe the 'Safety information' in Section 1.**

Referring to the Installation and Maintenance Instructions, name-plate and Technical Information Sheet, check that the product is suitable for the intended installation:

- 3.1** Check materials, pressure and temperature and their maximum values. If the maximum operating limit of the product is lower than that of the system in which it is being fitted, ensure that a safety device is included in the system to prevent overpressurisation.
- 3.2** Remove the protective covers from all connections.
- 3.3** Install the valve in the direction of flow given by the arrow on the body. The preferred position is with the spindle vertical. The valve can be installed from the vertical to the horizontal plane (see Figure 3).
- 3.4** Always open isolation valves slowly to avoid system shocks.
- 3.5** Note: It is advisable that when work is being carried out downstream of a valve installation, double isolation (block and bleed) should be fitted. In addition when installed as the final valve in a pipeline, as a safety precaution, a blanking plate or blank flange must be fitted to the outlet flange of the valve.
- 3.6** **Important note:** When a Balanced Valve is installed, the valve body should be mounted with the upstream fluid flowing into the upper valve chamber first (as per flow arrow), so that the fluid pressure acts on top of the Balancing Plug. This is opposite to normal installation. If a Balancing Plug is upgrading or replacing a standard plug, the original valve body must be turned around in the pipeline and permanently marked with a new flow arrow indicating the changed direction of flow.

**Do not mount the valve upside down.**

## What is a balancing plug, how does it work and why use it?

- A balancing plug is a two stage on/off mechanism
- (See Figure 2) The pre-lifting plug (**A**) acts as a pilot valve and is opened first, allowing the medium to pass through at a controlled rate. The differential pressure then reduces across the valve - allowing the main valve plug (**B**) to be easily lifted off its seat. To assist closing the valve the flowing medium must enter on the 'Bellows' side, this is the opposite to normal installation.
- This device is fitted in the first instance to allow easy closure of the larger valves. In normal flow conditions it is very difficult on large valves and high differential pressure to close the valve. By reversing the flow and installing a pilot valve, this problem is overcome.

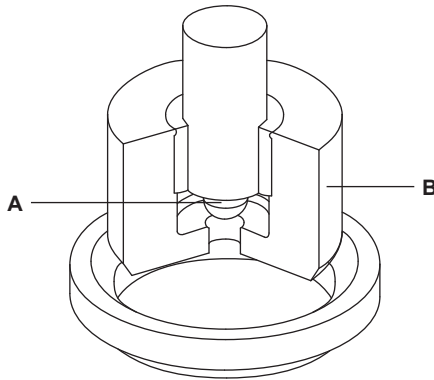

Fig. 2

## 4. Commissioning

After installation or maintenance ensure that the system is fully functioning. Carry out tests on any alarms or protective devices.

# 5. Operation

- 5.1 The bellows sealed isolation valve plays an important role in the conservation of energy by eliminating fugitive stem seal emissions.
- 5.2 The valve is operated manually by a handwheel. Special care must be taken to ensure that the movement is made in the correct direction.  
To open the valve fully, it is recommended to turn the handwheel until the shaft is raised to the maximum position, indicated by the (+) on the bonnet, then turn the handwheel clockwise 1¼ turns to remove any backlash.  
This is to prevent the possibility of attempting to force open a valve, which is already fully open, resulting in damage to the stem, bellows unit or other components.  
Spirax Sarco BSA valves are fitted with a position indicator which can be found on the stem, and on the bonnet support pillars. (+ = fully open / - = fully closed).
- 5.3 The use of valve keys is not recommended, however if used care must be taken not to damage the valve.

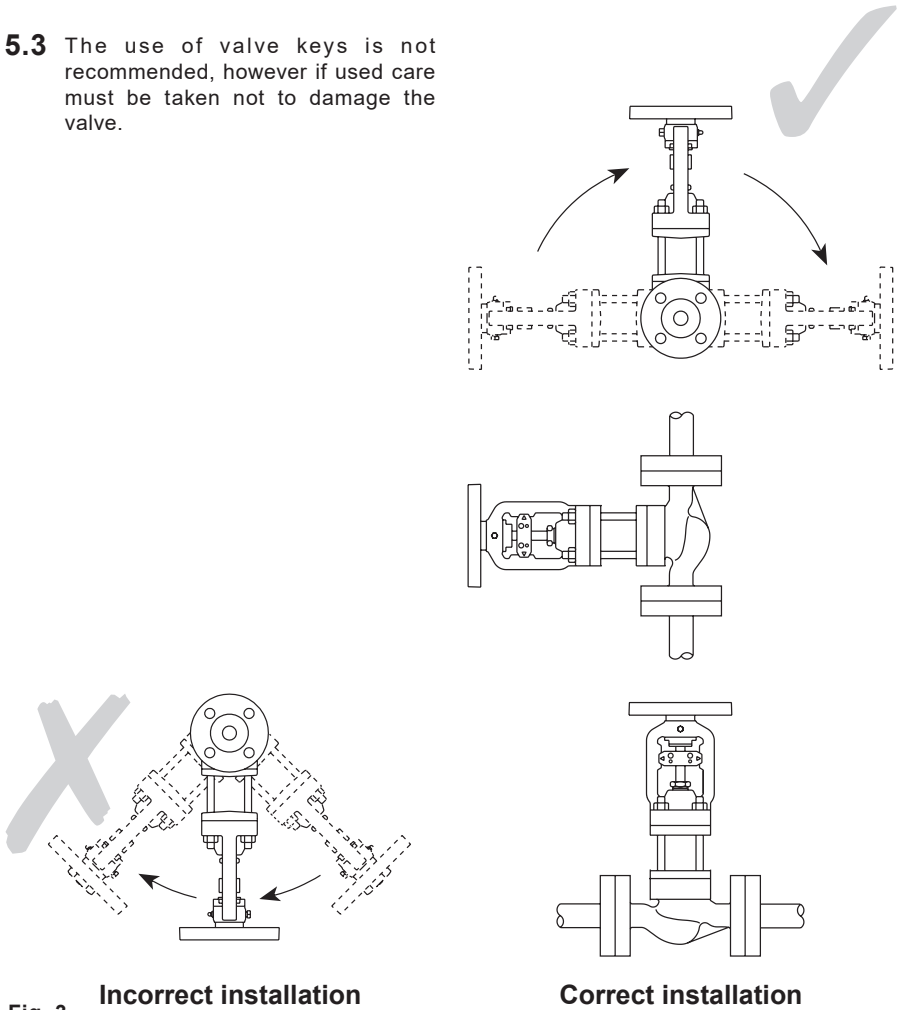

Fig. 3 Incorrect installation

Correct installation

# 6. Maintenance

All the internals of the bellows sealed valve can be replaced (See Section 7, Spare parts).

**Note:**

Before actioning any maintenance programme observe the data in Section 1 'Safety information'.

**Warning**

Before undertaking any maintenance on the valve, ensure that any pressure is isolated and safely vented to atmospheric pressure. The valve should then be allowed to cool. When reassembling, ensure that all joint faces are clean.

## 6.1 Replacing the handwheel

1. Remove circlip (15) with circlip pliers.
2. Slide off existing handwheel.
3. Ensure that thrust washer (13) is still present on top face of bonnet (5).
4. Ensure that all contact surfaces of the valve are clean and free of dirt to accept new handwheel.
5. Align flat of 'D' drive of new handwheel and that of the bonnet bush. Slide new handwheel into place.
6. Fit replacement circlip with circlip pliers.
7. Test operation of valve by rotating the valve between fully open and fully closed several times to ensure it is working properly before returning the valve to service.

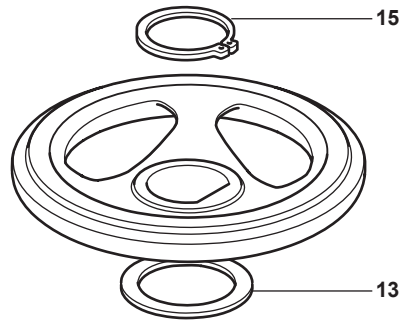

Fig. 4

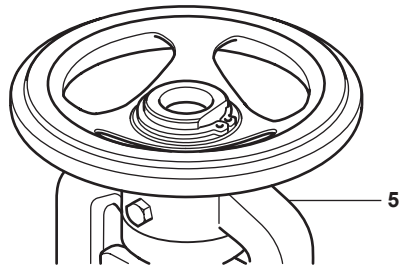



Fig. 5

## 6.2 Replacing the bellows, stem, plug and seat assembly

1. Loosen the gland nut (11) by a couple of turns.
2. Open the valve (using the handwheel) by a single rotation.
3. Loosen and remove the bonnet nuts (20).
4. Carefully lift the top half of the valve including the bonnet, handwheel, stem and plug assembly.
5. Lift the bellows housing (4) off of the studs.
6. Carefully remove the old gaskets (22) and clean the contact surfaces of the bellows housing. Also ensure that the mating surfaces of the body and bonnet are clean and free of dirt.
7. Remove the support cage (3) from inside the body.
8. Lift the seat (2) from the body. The gasket may lift with it.
9. If not, remove the seat gasket (21) and clean the contact surfaces.
10. Fit a new seat gasket (21) into the recess, ensuring that it sits flat.
11. Fit a new seat (2) onto the top of the gasket.
12. Refit the support cage (3).
13. Fit a new gasket(22) into the body recess.
14. Refit the bellows housing (4), ensure that orientation of bellows housing is such that counterbore is uppermost.
15. Fit a new gasket (23) in to the recess of the top of the bellows housing.
16. Support the bonnet assembly, by holding the bonnet casting horizontally (we recommend clamping in a vice).
17. Unscrew the two bonnet bolts that retain the stem couplings (17) and remove them from the stem.
18. Take hold of the plug (6) at the end of the stem, so it cannot rotate. Then rotate the handwheel gently clockwise until the stem is released from the bonnet bush.
19. Carefully slide the plug and stem assembly (6+7) from the bonnet (5).

**Steps 20 to 39 are on page 16**

## Recommended tightening torques

Valve size	 mm or inch		N m	lbf ft
DN15-DN25	22 A/F	1/2" UNC-13	75	55.3
DN32-DN50	27 A/F	5/8" UNC-11	135	99.6
DN65-DN100	32 A/F	3/4" UNC-10	240	177.0

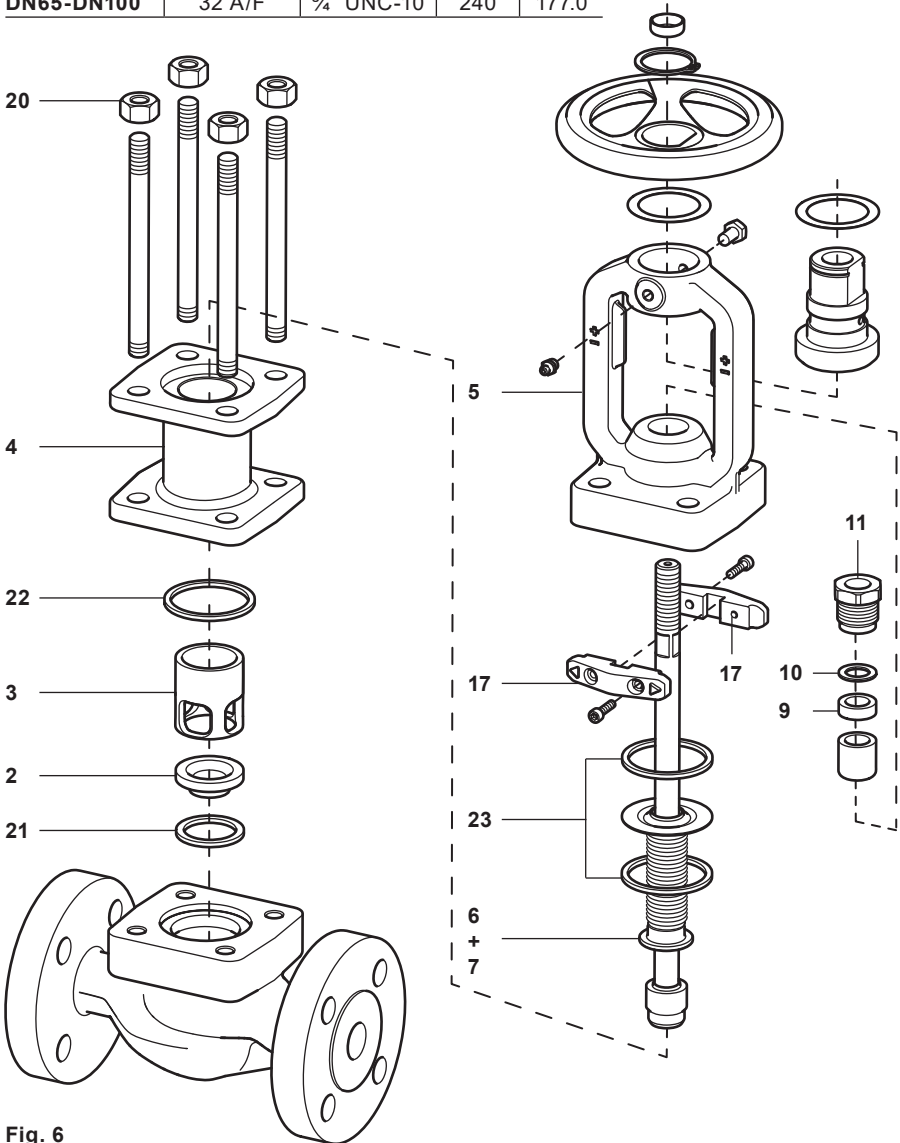



Fig. 6

## 6.2 Replacing the bellows, stem, plug and seat assembly

20. Remove the old gasket (23) from the bonnet and clean the contact surface.
21. Unscrew and then remove the gland nut (11).
22. Remove the gland ring (10) and graphite ring (9) from the bonnet.
23. Fit a new graphite ring (9).
24. Refit the gland ring (10).
25. Refit the gland nut (11) loosely (do not tighten).
26. Fit a new gasket (23) to the bonnet.
27. Carefully slide the new plug and stem assembly into the bonnet (take care not to damage any of the surfaces).
28. Push the plug and stem assembly into the bonnet bush and rotate the handwheel anti-clockwise until the thread engages. Keep rotating the handwheel as the plug and stem winds into the bonnet bush.
29. Wind on several turns until there is enough room to refit the stem couplings (17).
30. Align the flats on the stem to allow the stem couplings to be refitted. Tighten the two retaining screws.
31. Rotate the handwheel anti-clockwise until the stem couplings prevent further movement.
32. Lower the bonnet assembly gently into the bellows housing, making sure that the bonnet fits over the studs. Check that the underside of the bonnet has aligned with the bellows housing.
33. Replace the nuts and tighten by hand.
34. Rotate the handwheel, winding the valve into the closed position (clockwise). Close the valve gently, **do not apply full torque**.
35. Open the valve by unwinding the handwheel by several turns.
36. Tighten the bonnet nuts (20) in sequence to approximately half of the full torque.
37. Repeat instructions 34, 35 and 36, but tightening the bonnets to full torque setting.
38. Hand-tighten gland nut (11) after valve has been fully assembled.
39. The valve is now ready for use.



# Recommended tightening torques

Valve size	 mm or inch		N m	lbf ft
DN15-DN25	22 A/F	1/2" UNC-13	75	55.3
DN32-DN50	27 A/F	5/8" UNC-11	135	99.6
DN65-DN100	32 A/F	3/4" UNC-10	240	177.0

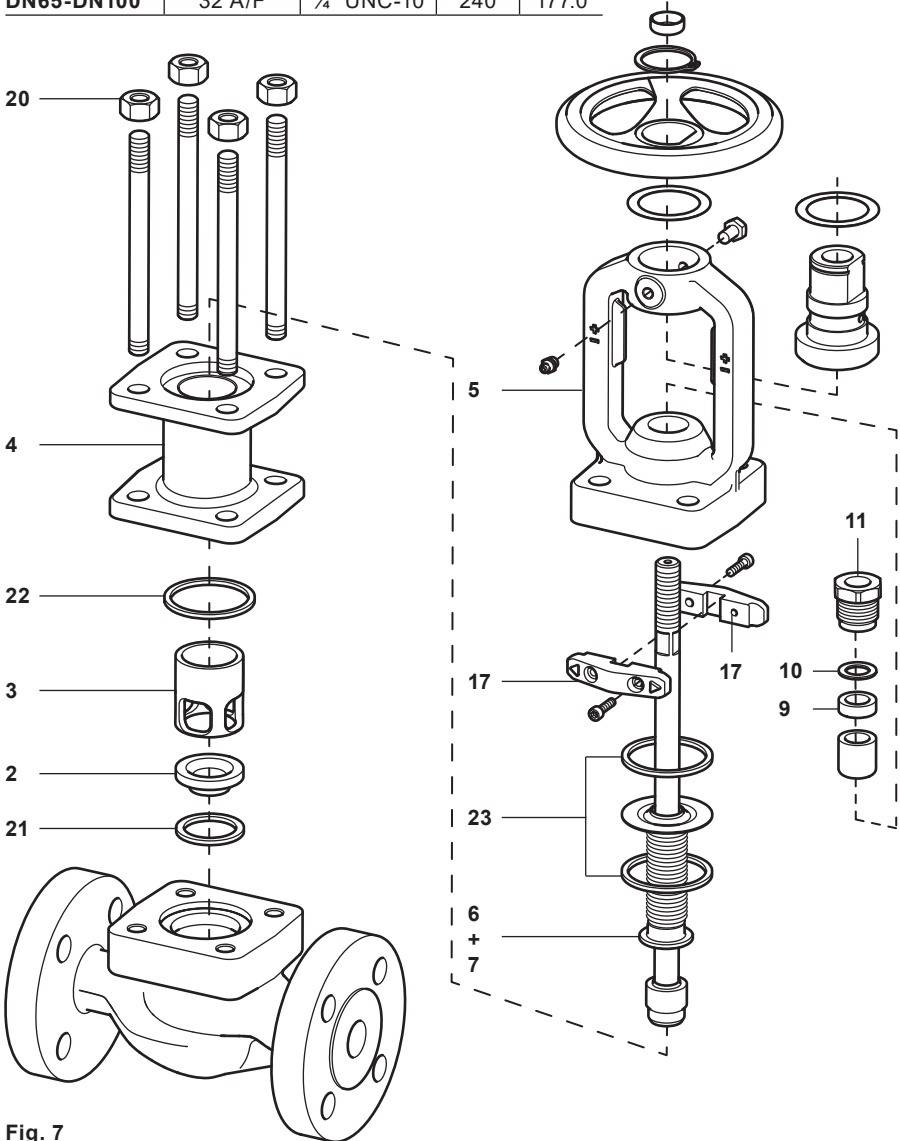

Fig. 7

# 7. Spare parts

## Warning

The body/bonnet collar gaskets contain a thin stainless steel support ring which may cause physical injury if they are not handled and disposed of carefully.

Care must be taken when opening and closing the handwheel to prevent any possible injury to the hands from the locking screw.

## Spare parts

The spare parts available are detailed below.  
No other parts are supplied as spares.

### Available spares

Seat/body/bonnet gaskets and graphite ring	9, 21, 22 and 23 (2 off)
Seat, plug, stem and bellows assembly (Gaskets not included)	2, 6 and 7
Handwheel and circlip	14 and 15

### How to order spares

Always order spares by using the description given in 'Available spares' and state the size and type of stop valve (balanced or unbalanced).

**Example:** 1 - Seat, plug, stem and bellows assembly for an unbalanced DN15 Spirax Sarco BSA3HP bellows sealed high pressure stop valve having EN1092 PN100 connections.

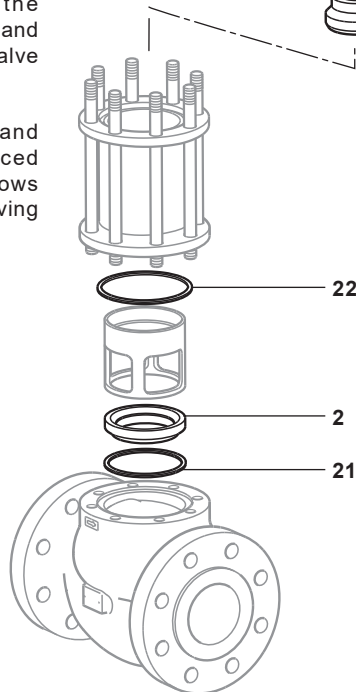
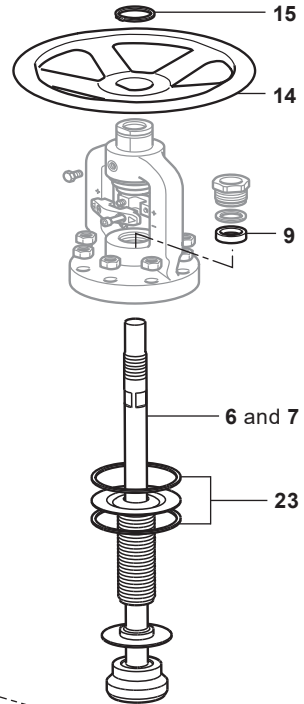

**Fig. 8 DN25  
PN100 BSA3HP shown**



