



SV73 Cast Iron Safety Valve

Description

The SV73 cast iron series valves are built in conformance to Section I and VIII of the ASME Boiler and Pressure Vessel Code. They are primarily intended for use on power boilers and unfired pressure vessels where ASME Section I and VIII stamped valves are required.

Applications

Protection of steam systems downstream of pressure regulating stations, on inlet to such equipment as air coils, heat exchangers and process vessels. Also for use on flash recovery vessels on condensate return systems to protect vessels. Air systems to protect accumulation vessels and air equipment from overpressurisation. Steam boilers and generators.

Available types

The SV73 is available with cast iron body and stainless steel trim in orifice sizes from 'J' to 'R'. It has an open bonnet and easing lever and is available with screwed or flanged connections.

Certification

A manufacturers' Typical Test Report is provided as standard for each valve which will include valve set and hydraulic test pressure. Also available on request is material certification in accordance with EN 10204 3.1.

Standards and approvals

Approved by National Board of Boiler and Pressure Vessel Inspectors to ASME Boiler and Pressure Vessel Code Sections I and VIII. Seat tightness is in accordance with ANSI/API STD 527-1992.

If National Board 'V' or 'UV' stamp is required, then this must be specified at the time of ordering.

Important note: SV73 safety valves are not  marked and therefore not to be used within the EEA.

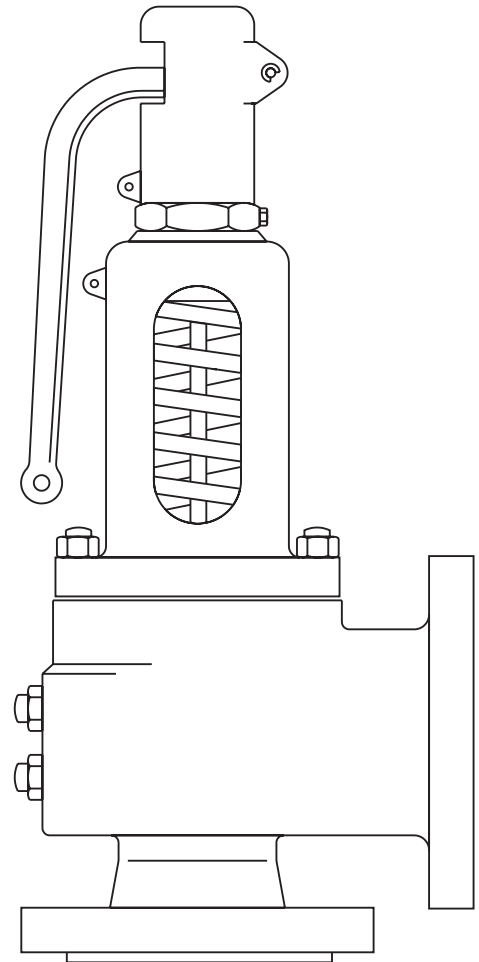

Sizes and end connections

1½" x 2½" to 3" x 4"	Inlet/outlet screwed female NPT.
1½" x 2½" to 3" x 4"	Inlet flanged ANSI class 250 RF, Outlet screwed female NPT.
3" x 4" to 6" x 8"	Inlet flanged ANSI class 250 RF, Outlet flanged ANSI class 125 FF.

Pressure/temperature limits

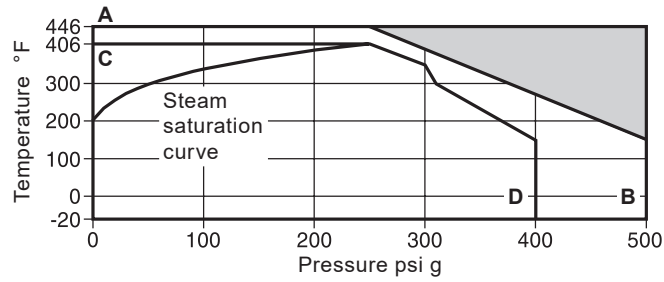

The product **must not** be used in this region.

A - B Limit for valves with a flanged inlet

C - D Limit for valves with a screwed inlet.

Body design conditions		ANSI 250		
Set pressure range	Maximum	250 psi g		
	Minimum	5 psi g		
Temperature	Maximum	Screwed inlet	406 °F	
		Flanged inlet	446 °F	
	Minimum	-20 °F		
Performance data	Overpressure	ASME I	Steam	3%
		ASME VIII	Steam	10%
	Air/gas		10%	
	Blowdown limits	ASME I	Steam	2 - 6%
		ASME VIII	Steam	7%
			Air/gas	7%
		Derated coefficient of discharge values	Steam	0.955
	Air/gas		0.955	
Maximum permitted backpressure up to:		10% of set pressure		
Tested at a maximum inlet cold hydraulic test pressure of:		600 psi g		

Materials

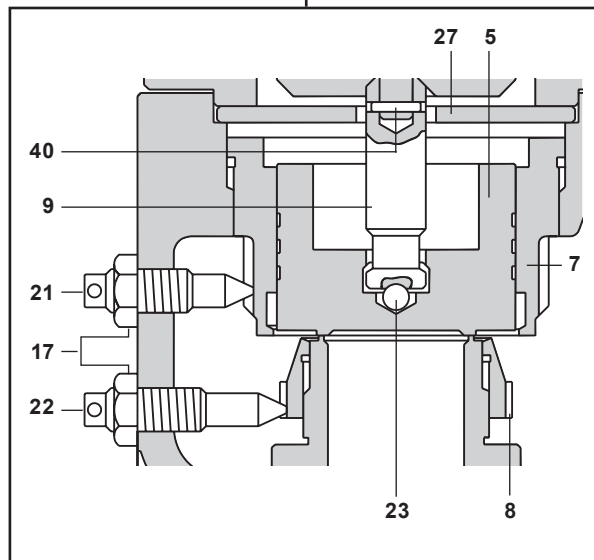
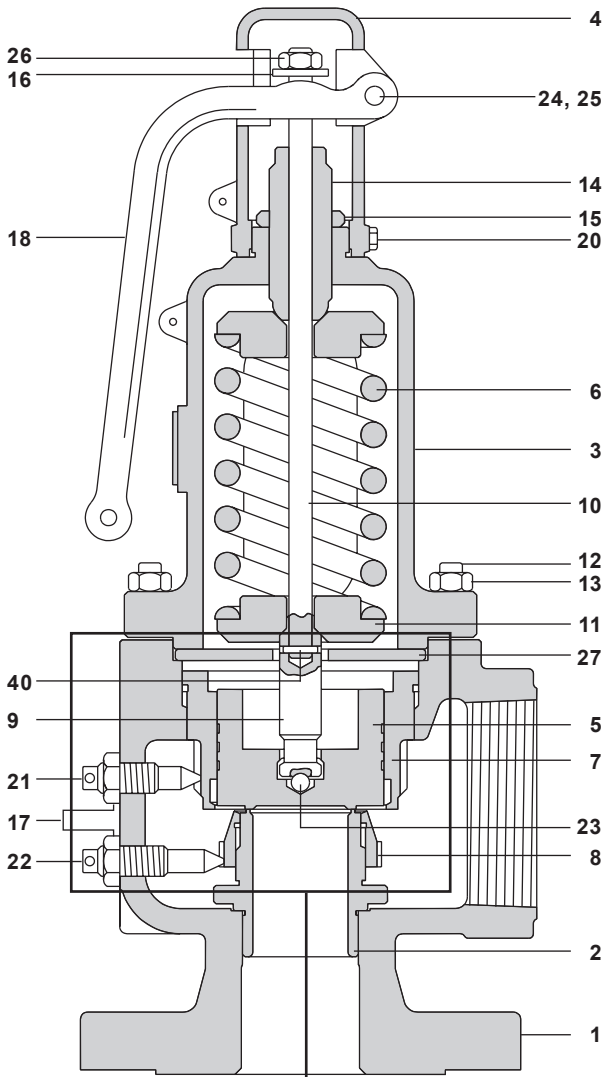

No.	Part	Material	
1	Body	Cast iron	ASTM A126 Class B
2	Seat	Stainless steel	ASTM A351 Grade CF8
3	Bonnet	Cast iron	ASTM A126 Class B
4	Cap	Cast iron	ASTM A126 Class B
5	Disc	Stainless steel	ASTM A217 CA15
6	Spring	Chrome-vanadium alloy steel	
7	Upper adjusting ring	Stainless steel	ASTM A351 Grade CF8
8	Lower adjusting ring	Stainless steel	ASTM A351 Grade CF8
9	Stem (lower)	Stainless steel	ASTM A479 Type 410
10	Stem (upper)	Stainless steel	ASTM A479 Type 410
11	Spring washers (2 off)	Steel	ASTM A105
12	Bonnet stud	Steel	ASTM A193 Grade B7
13	Bonnet nut	Steel	ASTM A194 Grade 2H
14	Adjusting screw	Stainless steel	ASTM A479 Type 410
15	Adjusting screw nut	Carbon steel	
16	Release ring	Carbon steel	
17	Lock-nut (2 off)	Carbon steel	
18	Lever	Grey iron	
20	Cap set screw	Carbon steel	
21	Upper adjusting ring pin	Stainless steel	
22	Lower adjusting ring pin	Stainless steel	
23	Disc ball	Stainless steel	
24	Pin washer	Carbon steel	
25	Lever pin	Carbon steel	
26	Lock-nut	Carbon steel	
27	Guide plate	Carbon steel	
40	Stem pin	Carbon steel	

Capacities

1. lb/h steam, 90% of actual capacity at 3% accumulation in accordance with ASME Code, Section I.

		Orifice		J		K		L		M	
		Area Sq. In.		1.374		1.968		3.054		3.846	
Steam saturation temperature °F	Set pressure psi g	Real flow		Real flow		Real flow		Real flow			
		lb/h 3%	lb/h 10%	lb/h 3%	lb/h 10%	lb/h 3%	lb/h 10%	lb/h 3%	lb/h 10%		
250	15	1 833	1 897	2 625	2 717	4 074	4 216	5 131	5 308		
259	20	2 146	2 231	3 074	3 196	4 770	4 959	6 007	6 244		
267	25	2 459	2 566	3 522	3 675	5 466	5 702	6 883	7 180		
274	30	2 772	2 900	3 971	4 153	6 162	6 446	7 760	8 116		
281	35	3 085	3 234	4 419	4 632	6 858	7 189	8 636	9 052		
287	40	3 398	3 569	4 868	5 111	7 554	7 932	9 513	9 987		
292	45	3 711	3 903	5 316	5 590	8 250	8 675	10 389	10 923		
298	50	4 025	4 237	5 764	6 069	8 945	9 418	11 265	11 859		
303	55	4 338	4 572	6 213	6 548	9 641	10 162	12 142	12 795		
307	60	4 651	4 906	6 661	7 027	10 337	10 905	13 018	13 730		
312	65	4 964	5 240	7 110	7 506	11 033	11 648	13 894	14 666		
316	70	5 277	5 575	7 558	7 985	11 729	12 391	14 771	15 602		
320	75	5 590	5 909	8 007	8 464	12 425	13 134	15 647	16 538		
324	80	5 903	6 244	8 455	8 943	13 121	13 878	16 524	17 474		
328	85	6 216	6 578	8 904	9 422	13 817	14 261	17 400	18 409		
331	90	6 529	6 912	9 352	9 901	14 513	15 364	18 276	19 345		
335	95	6 842	7 247	9 800	10 379	15 209	16 107	19 153	20 281		
338	100	7 155	7 581	10 249	10 858	15 905	16 850	20 029	21 217		
341	105	7 469	7 915	10 697	11 337	16 600	17 594	20 905	22 152		
344	110	7 782	8 250	11 146	11 816	17 296	18 337	21 782	23 088		
347	115	8 293	8 584	11 594	12 295	17 992	19 080	22 658	24 024		
350	120	8 408	8 918	12 043	12 774	18 688	19 823	23 535	24 960		
353	125	8 721	9 253	12 491	13 253	19 384	20 566	24 411	25 896		
356	130	9 034	9 587	12 940	13 732	20 080	21 310	25 287	26 831		
358	135	9 347	9 922	13 388	14 211	20 776	22 053	26 164	27 767		
361	140	9 660	10 256	13 836	14 690	21 472	22 796	27 040	28 703		
363	145	9 973	10 590	14 285	15 169	22 168	23 539	27 916	29 639		
366	150	10 286	10 925	14 733	15 648	22 864	24 282	28 793	30 574		
368	155	10 599	11 259	15 182	16 127	23 559	25 026	29 669	31 510		
371	160	10 913	11 593	15 630	16 605	24 255	25 769	30 546	32 446		
373	165	11 226	11 928	16 079	17 084	24 951	26 512	31 422	33 382		
375	170	11 539	12 262	16 527	17 563	25 647	27 255	32 298	34 317		
377	175	11 852	12 597	16 976	18 042	26 343	27 998	33 175	35 253		
380	180	12 165	12 931	17 424	18 521	27 039	28 742	34 051	36 189		
382	185	12 478	13 265	17 872	19 000	27 735	29 485	34 927	37 125		
384	190	12 791	13 600	18 321	19 479	28 431	30 228	35 804	38 061		
386	195	13 104	13 934	18 769	19 958	29 127	30 971	36 680	38 996		
388	200	13 417	14 268	19 218	20 437	29 823	31 714	37 557	39 932		
390	205	13 728	14 600	19 663	20 912	30 513	32 452	38 426	40 868		
392	210	14 043	14 937	20 115	21 395	31 214	33 201	39 309	41 804		
394	215	14 354	15 269	20 560	21 870	31 905	33 938	40 179	42 739		
396	220	14 670	15 606	21 008	22 352	32 606	34 687	41 062	43 675		
398	225	14 980	15 937	21 456	22 827	33 296	35 424	41 931	44 611		
399	230	15 296	16 275	21 908	23 310	33 998	36 174	42 815	45 547		
401	235	15 606	16 606	22 353	23 785	34 688	36 911	43 684	46 483		
403	240	15 922	16 943	22 805	24 268	35 390	37 660	44 568	47 418		
404	245	16 232	17 275	23 250	24 743	36 080	38 397	45 436	48 354		
406	250	16 548	17 612	23 702	25 226	36 782	39 146	46 320	49 290		

2. lb/h steam, 90% of actual capacity at 10% accumulation in accordance with ASME Code, Section VIII.

Orifice	N	P	Q	R
Area Sq. In.	4.633	6.830	11.811	17.123

Steam saturation temperature °F	Set pressure psi g	Real flow		Real flow		Real flow		Real flow	
		lb/h	lb/h	lb/h	lb/h	lb/h	lb/h	lb/h	lb/h
		3%	10%	3%	10%	3%	10%	3%	10%
250	15	6 181	6 395	9 111	9 427	15 756	16 302	22 842	23 634
259	20	7 236	7 522	10 668	11 089	18 447	19 176	26 744	27 800
267	25	8 292	8 649	12 224	12 751	21 139	22 050	30 646	31 966
274	30	9 348	9 776	13 780	14 413	23 830	24 923	34 548	36 133
281	35	10 403	10 904	15 337	16 074	26 521	27 797	38 449	40 299
287	40	11 459	12 031	16 893	17 736	29 213	30 671	42 351	44 465
292	45	12 515	13 158	18 449	19 398	31 904	33 545	46 253	48 631
298	50	13 570	14 286	20 006	21 060	34 595	36 418	50 155	52 797
303	55	14 626	15 413	21 562	22 722	37 287	39 292	54 057	56 964
307	60	15 682	16 540	23 118	24 383	39 978	42 166	57 958	61 130
312	65	16 738	17 667	24 675	26 045	42 670	45 040	61 860	65 296
316	70	17 793	18 795	26 231	27 707	45 361	47 913	65 762	69 462
320	75	18 849	19 922	27 567	29 369	48 052	50 787	69 664	73 629
324	80	19 905	21 049	29 344	31 031	50 744	53 661	73 565	77 795
328	85	20 960	22 176	30 900	32 693	53 435	56 535	77 467	81 961
331	90	22 016	23 304	32 456	34 354	56 126	59 408	81 369	86 127
335	95	23 072	24 431	34 013	36 016	58 818	62 282	85 271	90 294
338	100	24 128	25 558	35 569	37 678	61 509	65 156	89 173	94 460
341	105	25 183	26 685	37 125	39 340	64 200	68 030	93 074	98 626
344	110	26 239	27 813	38 682	41 002	66 892	70 903	96 976	102 792
347	115	27 295	28 940	40 238	42 663	69 583	73 777	100 878	106 958
350	120	28 350	30 067	41 001	44 325	72 274	76 651	104 780	111 125
353	125	29 406	31 194	43 351	45 987	74 966	79 525	108 681	115 291
356	130	30 462	32 322	44 907	47 649	77 657	82 398	112 583	119 457
358	135	31 518	33 449	46 463	49 311	80 348	85 272	116 485	123 623
361	140	32 573	34 576	48 020	50 973	83 040	88 146	120 387	127 790
363	145	33 629	35 704	49 576	52 634	85 731	91 020	124 288	131 956
366	150	34 685	36 831	51 132	54 296	88 422	93 893	128 190	136 122
368	155	35 740	37 958	52 689	55 958	91 114	96 767	132 092	140 288
371	160	36 796	39 085	54 245	57 620	93 805	99 641	135 994	144 454
373	165	37 852	40 212	55 801	59 282	96 496	102 515	139 896	148 621
375	170	38 907	41 340	57 358	60 943	99 188	105 388	143 797	152 787
377	175	39 963	42 467	58 914	62 605	101 879	108 262	147 699	156 953
380	180	41 019	43 594	60 470	64 267	104 570	111 136	151 601	161 119
382	185	42 075	44 722	62 027	65 929	107 262	114 010	155 503	165 286
384	190	43 130	45 849	63 583	67 591	109 953	116 883	159 404	169 452
386	195	44 186	46 976	65 139	69 253	112 644	119 757	163 306	173 618
388	200	45 242	48 103	66 696	70 914	115 336	122 631	167 208	177 784
390	205	46 290	49 231	68 240	72 576	118 007	125 505	171 080	181 951
392	210	47 353	50 358	69 808	74 238	120 718	128 378	175 012	186 117
394	215	48 401	51 485	71 352	75 900	123 389	131 252	178 883	190 283
396	220	49 465	52 612	72 921	77 562	126 101	134 126	182 815	194 449
398	225	50 512	53 740	74 465	79 223	128 770	137 000	186 685	198 615
399	230	51 576	54 867	76 034	80 885	131 484	139 874	190 619	202 782
401	235	52 623	55 994	77 577	82 547	134 152	142 747	194 487	206 948
403	240	53 687	57 122	79 146	84 209	136 866	145 621	198 422	211 114
404	245	54 734	58 249	80 689	85 871	139 534	148 495	202 289	215 280
406	250	55 799	59 376	82 259	87 533	142 249	151 369	206 226	219 447

Safety valve sizing information

Formulas:

For steam service: $A = \frac{\dot{m}_s}{0.9 (51.45 P K_d K_{sh})}$

For organic fluid vaporizers - lb/h: $A = \frac{\dot{m} \sqrt{T} \sqrt{Z}}{0.9 C K_d P \sqrt{M}}$

Where:

- A** = Required orifice area in square inches
- P** = Relieving pressure in pounds per square inch absolute = set pressure (psi g) + overpressure + 14.7 where the overpressure is 3% or 2 psi, whichever is the greater. P = 1.03 x set pressure + 14.7 or P = set pressure + 2 psi + 14.7.
- T** = Inlet temperature, °F. Absolute (°F plus 460).
- \dot{m}_s = Required steam capacity in pounds per hour.
- \dot{m} = Required vapor capacity in pounds per hour.
- K_d** = Coefficient of discharge, 0.955 for steam, air and vapour service.
- K_{sh}** = Steam superheat correction factor.
- M** = Average molecular weight of vapour.
- C** = Gas or vapour flow constant.
- Z** = Compressibility factor corresponding to T and P. If this factor is not available, compressibility correction can be safely ignored using a value of Z = 1.0.

Table 1 Ksh superheat correction factor

Total steam temperature °F	Set pressure psi g													
	15	20	40	60	80	100	120	140	160	180	200	220	240	250
	Saturated steam temperature °F													
	250	259	287	308	324	338	350	361	371	380	388	395	403	406
280	1.00	1.00												
300	1.00	1.00	1.00											
320	1.00	1.00	1.00	1.00										
340	0.99	0.99	1.00	1.00	1.00									
360	0.99	0.99	0.99	0.99	1.00	1.00	1.00							
380	0.98	0.98	0.99	0.99	0.99	1.00	1.00	1.00	1.00					
400	0.98	0.98	0.98	0.98	0.99	0.99	0.99	1.00	1.00	1.00	1.00	1.00		
420	0.97	0.97	0.97	0.97	0.98	0.98	0.98	0.99	0.99	0.99	0.99	1.00	1.00	1.00

Sizing and selection

Refer to:- <http://www.spiraxsarco.com/resources/steam-engineering-tutorials/safety-valves/safety-valve-sizing.asp>

Dimensions, weights and orifice sizes (approximate) in inches and lbs

Valve inlet		Valve outlet		Orifice letter	A ins	A1 ins	B ins	C ins	Weight lbs
Size	Connection	Size	Connection						
1½"	NPT	2½"	NPT	J	3.5	-	4.3	15.8	33
2"	NPT	3"	NPT	K	4.0	-	4.6	17.1	46
2½"	NPT	4"	NPT	L	4.6	-	5.5	18.5	66
3"	NPT	4"	NPT	M	5.1	-	5.6	24.3	93
1½"	ANSI 250	2½"	NPT	J	3.5	-	4.3	15.8	38
2"	ANSI 250	2½"	NPT	J	3.5	-	4.3	15.8	40
2"	ANSI 250	3"	NPT	K	4.0	-	4.6	17.1	49
2½"	ANSI 250	3"	NPT	K	4.0	-	4.6	17.1	51
2½"	ANSI 250	4"	NPT	L	4.6	-	5.5	19.5	71
3"	ANSI 250	4"	NPT	L	4.6	-	5.5	19.5	73
3"	ANSI 250	4"	NPT	M	5.1	-	5.4	24.3	101
3"	ANSI 250	4"	ANSI 125	L	-	5.5	5.5	19.5	82
3"	ANSI 250	4"	ANSI 125	M	-	5.5	5.4	24.3	110
4"	ANSI 250	6"	ANSI 125	N	-	7.1	6.8	26.5	187
4"	ANSI 250	6"	ANSI 125	P	-	7.1	6.8	28.5	196
6"	ANSI 250	8"	ANSI 125	Q	-	9.3	9.3	34.5	355
6"	ANSI 250	8"	ANSI 125	R	-	10.0	10.9	43.9	595

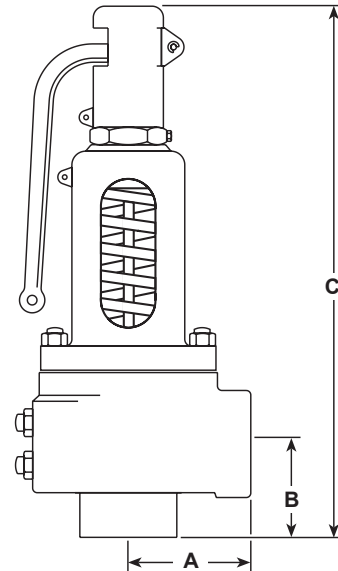
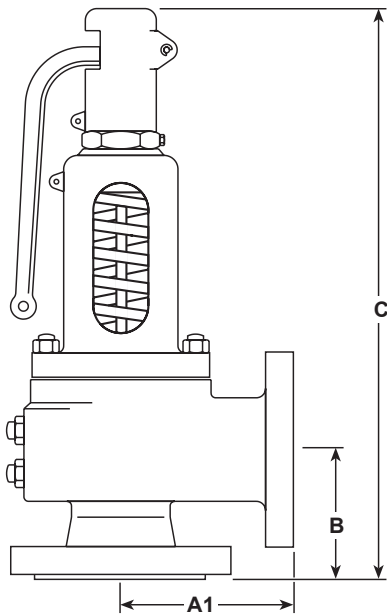

Safety information, installation and maintenance

For full details see the Installation and Maintenance Instructions (IM-S13-33) supplied with the product.

Installation note: The safety valve should always be fitted with the centre line of the spring housing vertically above the valve.

SV7 safety valve selection guide

Series number	SV7	SV7
Construction	3 = Cast iron	3
ASME section	V = ASME Code Section I U = ASME Code section VIII Blank = Valve without code stamp	V
Size and connection	A = 1½" NPT x 2½" NPT B = 2" NPT x 3" NPT C = 2½" NPT x 4" NPT D = 3" NPT x 4" NPT E = 1½" ANSI 250 x 2½" NPT F = 2" ANSI 250 x 2½" NPT G = 2" ANSI 250 x 3" NPT H = 2½" ANSI 250 x 3" NPT I = 2½" ANSI 250 x 4" NPT J = 3" ANSI 250 x 4" NPT L = 3" ANSI 250 x 4" ANSI 125 N = 4" ANSI 250 x 6" ANSI 125 Q = 6" ANSI 250 x 8" ANSI 125	A
Actual orifice area Sq. In.	J = 1.374 K = 1.968 L = 3.054 M = 3.846 N = 4.633 P = 6.830 Q = 11.811 R = 17.123	J
Set pressure	Specify set pressure from 5 psi g to 250 psi g	180

SV7	3	-	V	-	A	J	-	180
-----	---	---	---	---	---	---	---	-----

How to order

Example: 1 off Spirax Sarco SV73-V-AJ-180 safety valve having a set pressure of 180 psi g.