



TI-P133-77
ST Issue 4

M21Si ISO and M21Vi ISO Reduced Bore Ball Valves DN15 to DN150 Flanged PN40

Description

Both the M21Si and M21Vi are reduced bore ball valves, with a single piece body, having ISO mounting as standard. They are designed to be isolating valves, which can be used with the majority of industrial fluids, not control valves.

Available types

M21Si2 ISO	Zinc plated carbon steel body, PDR 0.8 seats.
M21Si3 ISO	Stainless steel body, PDR 0.8 seats.
M21Vi2 ISO	Zinc plated carbon steel body, PTFE seats.
M21Vi3 ISO	Stainless steel body, PTFE seats.

Standards

These products fully comply with the requirements of the European Pressure Equipment Directive 97/23/EC and carry the  mark when so required.

Certification

These product are available with certification to EN 10204 3.1.
Note: All certification/inspection requirements must be stated at the time of order placement.

Sizes and pipe connections

DN15, DN20, DN25, DN32, DN40, DN50, DN65, DN80, DN100 and DN150

Standard flange: EN 1092 PN40

Face-to-face dimensions:

- DN15 to DN100 according to DIN 3202 F4.
- DN25 to DN150 according to BS 2080.

Technical data

Flow characteristic	Modified linear
Port	Reduced bore
Leakage test procedure to ISO 5208 (Rate A)/EN 12266-1 (Rate A)	
Antistatic device	Complies with ISO 7121 and BS 5351

DN15 to DN50

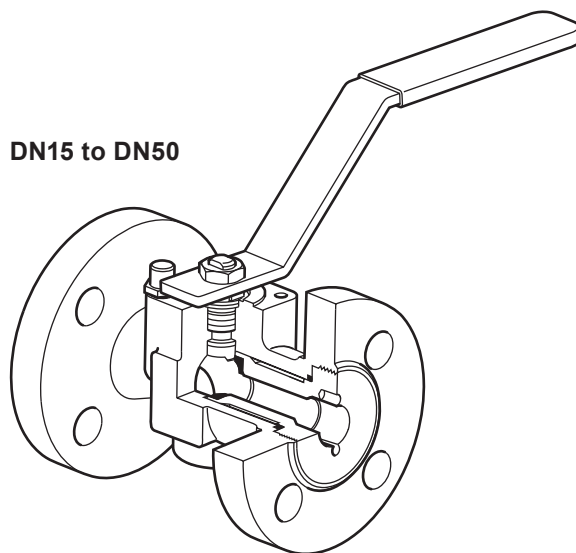

DN65

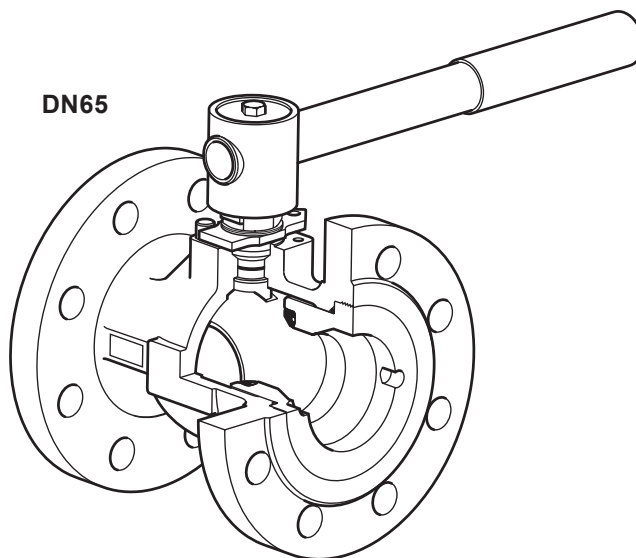

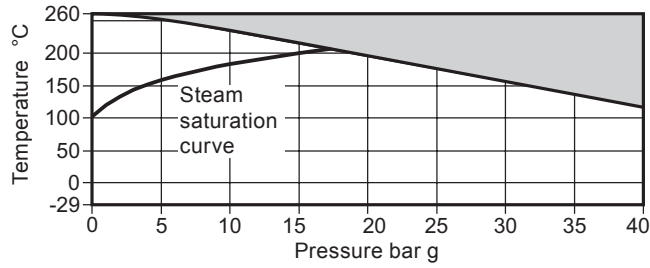

Pressure/temperature limits

M21Si2 ISO and M21Si3 ISO - PDR 0.8 seats

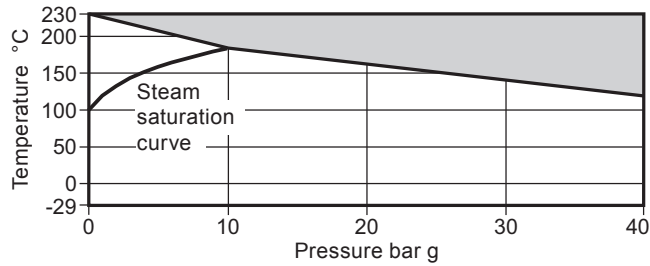

M21Vi2 ISO and M21Vi3 ISO - PTFE seats



 The product **must not** be used in this region.

Body design conditions		PN40
PMA	Maximum allowable pressure	M21Si 40 bar g @ 120 °C
		M21Vi 40 bar g @ 120 °C
TMA	Maximum allowable temperature	M21Si 260 °C @ 0 bar g
		M21Vi 230 °C @ 0 bar g
Minimum allowable temperature		-29 °C
PMO	Maximum operating pressure for saturated steam service	M21Si 17.5 bar g
		M21Vi 10.0 bar g
TMO Maximum operating temperature		260 °C @ 0 bar g
Minimum operating temperature		-29 °C
Note: For lower operating temperatures consult Spirax Sarco		
ΔPMX Maximum differential pressure is limited to the PMO		
Designed for a maximum cold hydraulic test pressure of 60 bar g		

DN15 to DN50

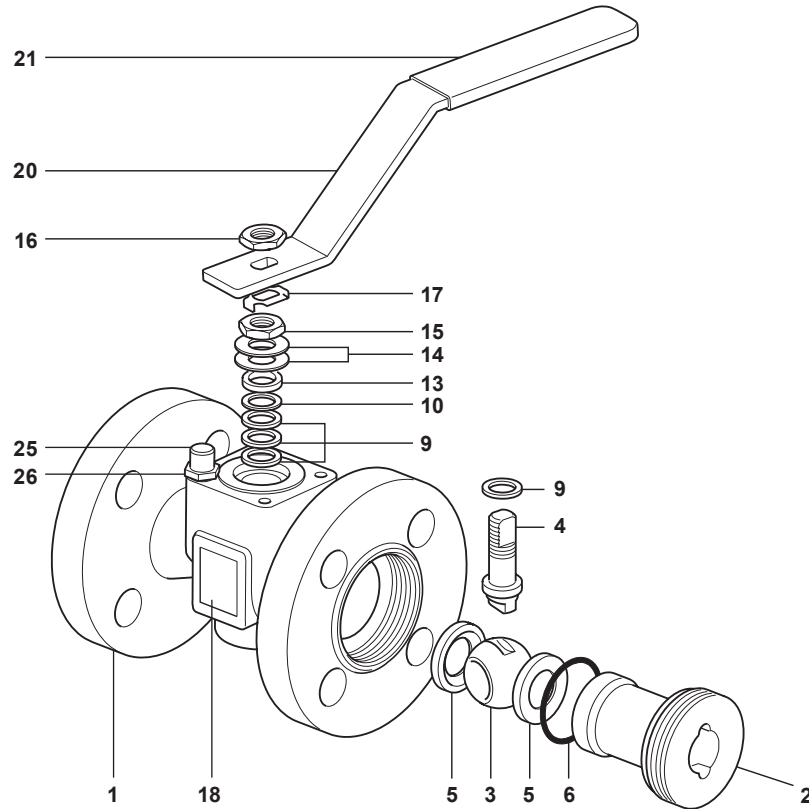

Materials

No.	Part		Material	
1	Body	M21Si2 ISO and M21Vi2 ISO	Zinc plated carbon steel	ASTM A216 WCB
		M21Si3 ISO and M21Vi3 ISO	Stainless steel	ASTM A351 CF8M
2	Insert	M21Si2 ISO and M21Vi2 ISO	Zinc plated carbon steel	SAE 1040
		M21Si3 ISO and M21Vi3 ISO	Stainless steel	AISI 316
3	Ball		Stainless steel	AISI 316
4	Stem		Stainless steel	AISI 316
5	Seat	M21Si2 ISO and M21Si3 ISO	Carbon and graphite reinforced PTFE	PDR 0.8
		M21Vi2 ISO and M21Vi3 ISO	Virgin PTFE	
6	Insert 'O' ring		EPDM	Geothermal
9	Stem seal		Antistatic R-PTFE	
10	Stem seal		Stainless steel	AISI 304
13	Separator		Zinc plated carbon steel	SAE 1010
14	Belleville washer		Stainless steel	AISI 301
15	Gland nut		Zinc plated carbon steel	SAE 1010/SAE 12L14
16	Upper steam nut		Zinc plated carbon steel	SAE 1010/SAE 12L14
17	Locking plate		Stainless steel	AISI 304
18	Nameplate		Stainless steel	AISI 430
20	Lever		Zinc plated carbon steel	SAE 1010
21	Grip		Vinyl	
25	Stop screw		Zinc plated carbon steel	SAE 12L14
26	Split lock washer		Stainless steel	AISI 304

DN65

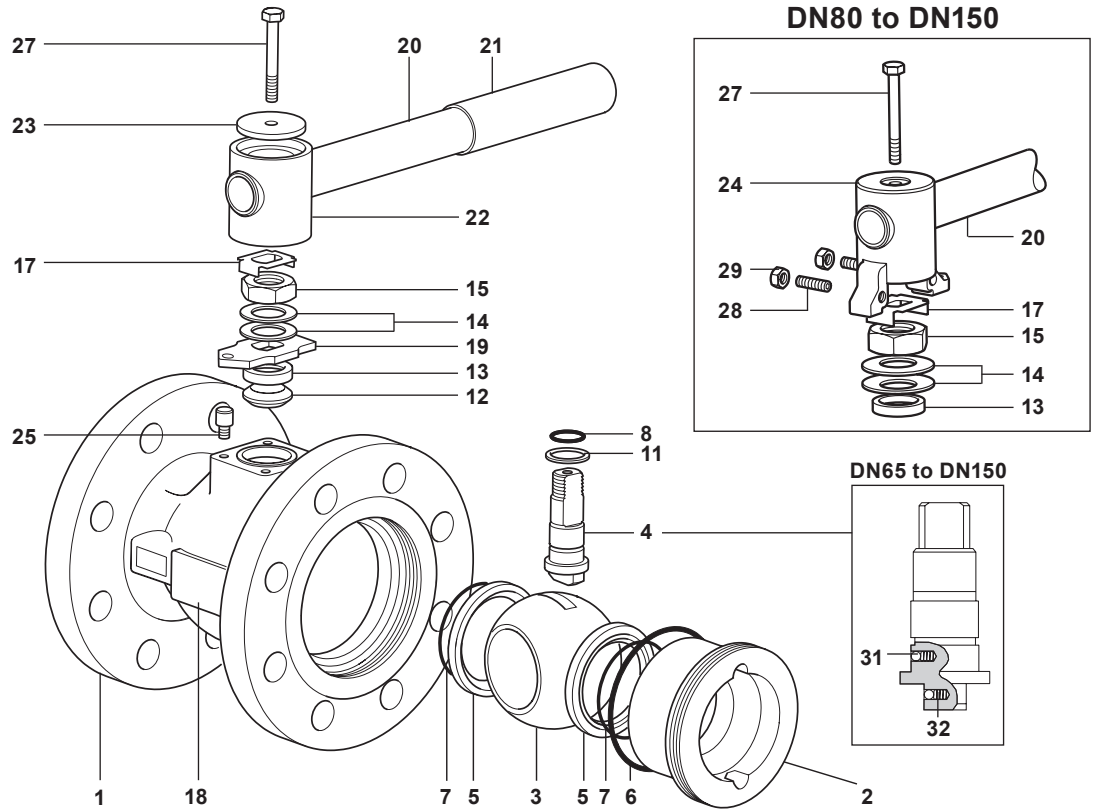

Materials

No.	Part		Material	
1	Body	M21Si2 ISO and M21Vi2 ISO	Zinc plated carbon steel	ASTM A216 WCB
		M21Si3 ISO and M21Vi3 ISO	Stainless steel	ASTM A351 CF8M
2	Insert	M21Si2 ISO and M21Vi2 ISO	Zinc plated carbon steel	SAE 1040
		M21Si3 ISO and M21Vi3 ISO	Stainless steel	AISI 316
3	Ball		Stainless steel	AISI 316
4	Stem		Stainless steel	AISI 316/AISI 420
5	Seat	M21Si2 ISO and M21Si3 ISO	Carbon and graphite reinforced PTFE	PDR 0.8
		M21Vi2 ISO and M21Vi3 ISO	Virgin PTFE	
6	Insert 'O' ring		EPDM	Geothermal
7	Seat 'O' ring		EPDM	Geothermal
8	Stem 'O' ring		EPDM	Geothermal
11	Lower stem seal		Antistatic R-PTFE	
12	Upper stem packing		Virgin PTFE	
13	Separator		Zinc plated carbon steel	SAE 1010
14	Belleville washer		Carbon steel/stainless steel	
15	Gland nut		Zinc plated carbon steel	SAE 1010/SAE 12L14
17	Locking plate		Stainless steel	AISI 304
18	Nameplate		Stainless steel	AISI 430
19	Stop plate with indicator	DN65 only	Zinc plated carbon steel	SAE 1010
20	Lever		Zinc plated carbon steel	SAE 1010
21	Grip		Vinyl	
22	Adaptor		Zinc plated SG iron	
23	Adaptor plate		Zinc plated carbon steel	SAE 1010
24	Adaptor with indicator	DN80 to DN150	Zinc plated SG iron	
25	Stop screw	DN80 to DN150	Zinc plated carbon steel	SAE 12L14
27	Adaptor screw		Zinc plated carbon steel	Grade 5
28	Stop screw	DN80 to DN150	Carbon steel	
29	Adaptor hex. nut	DN80 to DN150	Zinc plated carbon steel	
31	Antistatic device ball		Stainless steel	AISI 302
32	Antistatic device spring		Stainless steel	AISI 301

Dimensions/weights (approximate) in mm and kg
PN40 DIN 3202 F4 flanges

Size	A	B	C	D	E	F	Weight
DN15	115	57	162	95	95	13	2.5
DN20	120	60	162	105	95	13	3.2
DN25	125	62	162	115	101	19	4.0
DN32	130	65	182	140	106	25	5.5
DN40	140	70	186	150	118	30	6.9
DN50	150	75	186	165	123	37	9.3
DN65	170	79	278	185	144	50	13.4
DN80	180	91	417	200	157	57	17.7
DN100	190	98	517	235	172	75	25.0
DN150	-	-	-	-	-	-	-

PN40 BS 2080 flanges

Size	A	B	C	D	E	F	Weight
DN15	-	-	-	-	-	-	-
DN20	-	-	-	-	-	-	-
DN25	165	62	162	115	101	19	4.2
DN32	178	65	182	140	106	25	5.9
DN40	190	70	186	150	118	30	7.4
DN50	216	75	186	165	123	37	10.2
DN65	241	79	278	185	144	50	14.9
DN80	283	91	417	200	157	57	20.2
DN100	305	98	517	235	172	75	29.4
DN150	403	130	700	300	205	100	56.9

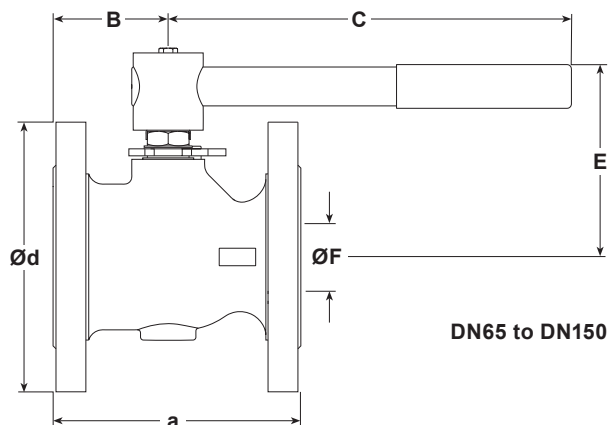
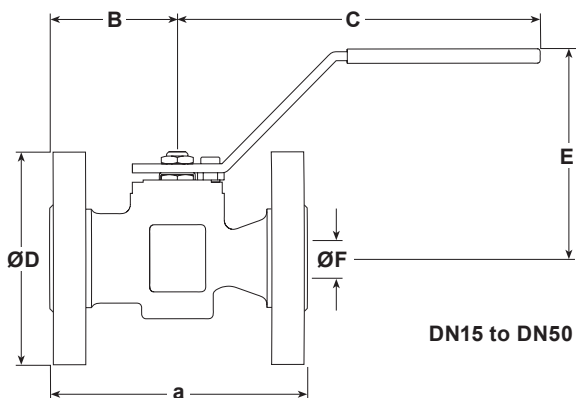

K_v values

DN	15	20	25	32	40	50	65	80	100	150
K _v	10	10	30	40	81	103	197	248	581	735

For conversion C_v (UK) = K_v x 0.963 C_v (US) = K_v x 1.156

Operating torque (N m)

DN	15	20	25	32	40	50	65	80	100	150
N m	8	8	10	15	20	25	50	70	100	155

Note: The torque figures shown are for a valve that is frequently operated at the maximum operating pressure. Valves that are subject to long static periods, may require a greater break-out torque.

Safety information, installation and maintenance

For full details see the Installation and Maintenance Instructions supplied with the product.

Welding

Only the models that have connections designed for welding (SW, BW, Imperial Tube connections) should be welded. Valves with flanged connections must not be welded to avoid damages to the valve and/or injury to personnel.

How to order

Specify	Model	Seat material	S = Carbon and graphite reinforced PTFE - PDR 0.8 V = Virgin PTFE
	Material	Body material	2 = Zinc plated carbon steel 3 = Stainless steel

Example: 1 off Spirax Sarco DN50 M21Si2 ISO ball valve having flanged EN 1092 PN40 connections.

Optional extras:

- Self-venting ball.
- Extended stems to allow full insulation: 50 mm (2") for DN15 to DN50 sizes and 100 mm (4") for DN65 to DN150 sizes.
- Lockable handle.
- 100 mm extended stem with lockable handle.

DN15 to DN50 - Spare parts (see page 7 for sizes DN65 - DN150)

The spare parts available are shown in solid outline. Parts drawn in a grey line are not supplied as spares.

Available spares

Seats, insert 'O' ring and stem seals

5, 6, 9, 10

How to order spares

Always order spares by using the description given in the column headed 'Available spares' and state the size and type of ball valve.

Example: 1 set of seats, insert 'O' ring and stem seals for a Spirax Sarco DN50 flanged PN40 M21Si2 ball valve.

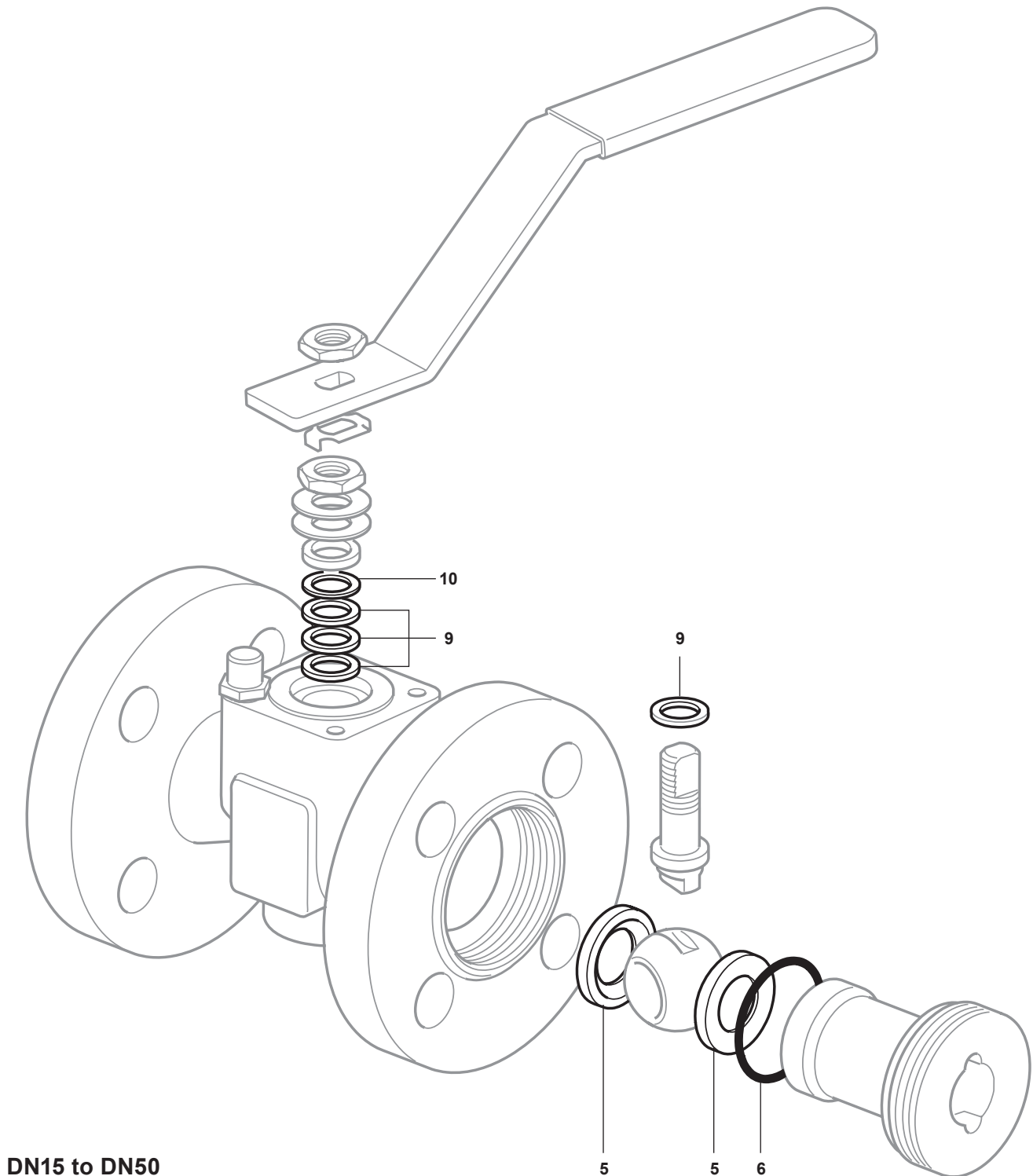

DN15 to DN50

DN65 to DN150 - Spare parts (see page 6 for sizes DN15 - DN50)

The spare parts available are shown in solid outline. Parts drawn in grey line are not supplied as spares.

Available spares

Seats, insert 'O' ring, seat 'O' ring, stem 'O' ring, lower stem seals and upper stem packing

5, 6, 7, 8, 11, 12

How to order spares

Always order spares by using the description given in the column headed 'Available spares' and state the size and type of ball valve.

Example: 1 set of seats, insert 'O' ring, seat 'O' ring, stem 'O' ring, lower stem seals and upper stem packaging for a Spirax Sarco DN80 flanged PN40 M21Si2 ball valve.

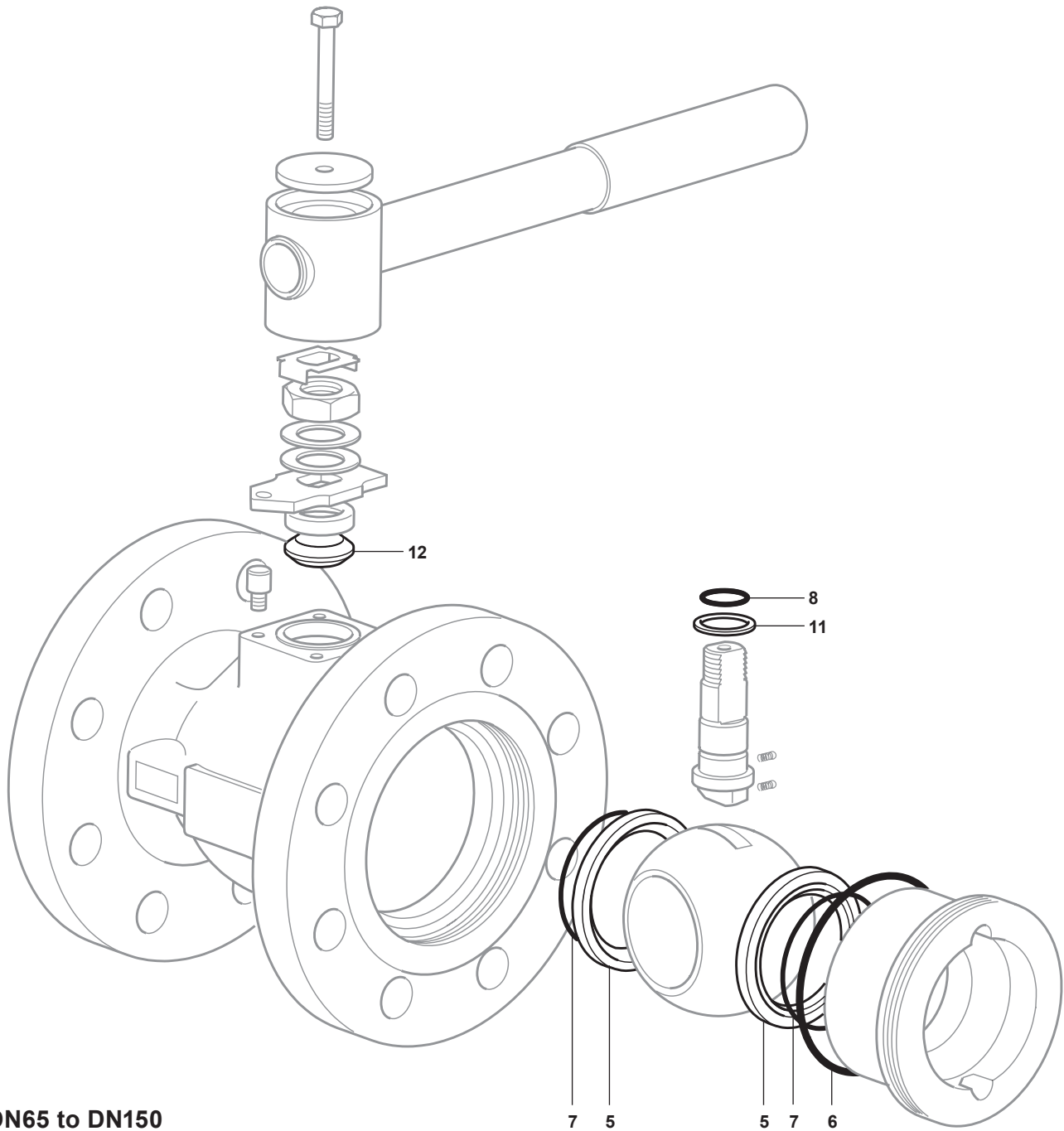

DN65 to DN150