



## DP163, DP163G and DP163Y Pilot Operated

# Pressure Reducing Valves with Stainless Steel Bodies

### Description

The DP163, DP163G and DP163Y pilot operated pressure reducing valves have been manufactured using stainless steel.

### Available types

**DP163** Suitable for steam applications

**DP163G** Is a soft seal version available for compressed air and inert industrial gases.  
**Note:** It is not recommended for oxygen service.

**DP163Y** Having a lower rate pressure control spring is suitable for steriliser/autoclave applications

### Standards

This product fully complies with the requirements of the Pressure Equipment Directive (PED) and carries the **CE** mark when so required.

### Certification

This product is available with certification to EN 10204 3.1.

**Note:** All certification/inspection requirements must be stated at the time of order placement.

### Sizes and pipe connections

DN15LC - Low Capacity version, DN15, DN20, DN25, DN32, DN40, DN50 and DN80.

Standard flanges: EN 1092 PN25 and PN40, BS 10 Table 'J' and ASME (ANSI) 300.

Available on request: ASME (ANSI) 150 and JIS 20.

### K<sub>v</sub> values

The K<sub>v</sub> maximum values shown below are full capacities and should be used for safety valve sizing purposes only.

DN15LC	DN15	DN20	DN25	DN32	DN40	DN50	DN80
1.0	2.8	5.5	8.1	12.0	17.0	28.0	64.0

For conversion:

$$C_v \text{ (UK)} = K_v \times 0.963$$

$$C_v \text{ (US)} = K_v \times 1.156$$

**Note:** Where the internal balance pipe is used the valve capacity will be reduced.

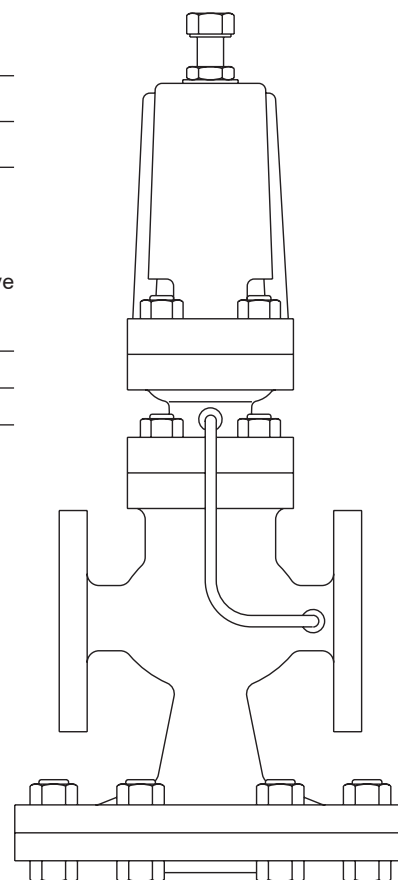

## Pressure/temperature limits

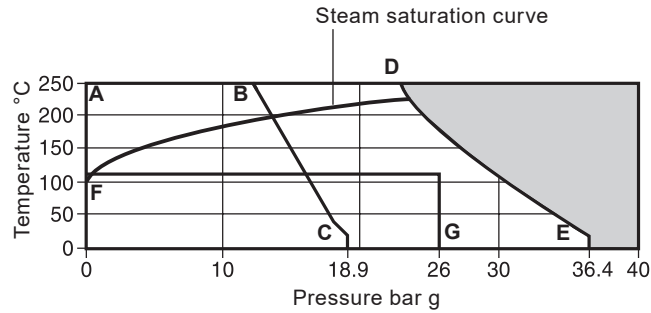

The product **must not** be used in this region.

**A-D-E** Flanged EN 1092 PN40, BS 10 Table J and ASME (ANSI) 300.

**A-B-C** Flanged ASME (ANSI) 150.

**F-G** DP163G limited to 120 °C @ 26 bar g.

**Note:** Two colour coded pressure adjustment springs are available for the following downstream pressure ranges:

**Red** 0.2 bar g to 17 bar g

**Grey** 16.0 bar g to 21 bar g

**Yellow** 0.2 bar g to 3.0 bar g (DP163Y only)

Body design conditions		PN40
Maximum design pressure	<b>A-D-E</b>	36.4 bar g @ 20 °C
	<b>A-B-C</b>	18.9 bar g @ 20 °C
Maximum design temperature		250 °C @ 24 bar g
Minimum design temperature		-10 °C
Maximum upstream pressure for saturated steam service	<b>A-D-E</b>	25 bar g
	<b>A-B-C</b>	14 bar g
Maximum operating temperature	<b>A-D-E</b>	250 °C @ 24 bar g
	<b>A-B-C</b>	250 °C @ 12.1 bar g
Minimum operating temperature		0 °C
Note: For lower operating temperatures consult Spirax Sarco		
Maximum differential pressure	<b>A-D-E</b>	25 bar g
	<b>A-B-C</b>	14 bar g
Designed for a maximum cold hydraulic test pressure of:		60 bar g
<b>Note:</b> With internals fitted, test pressure must not exceed:		40 bar g

## Materials

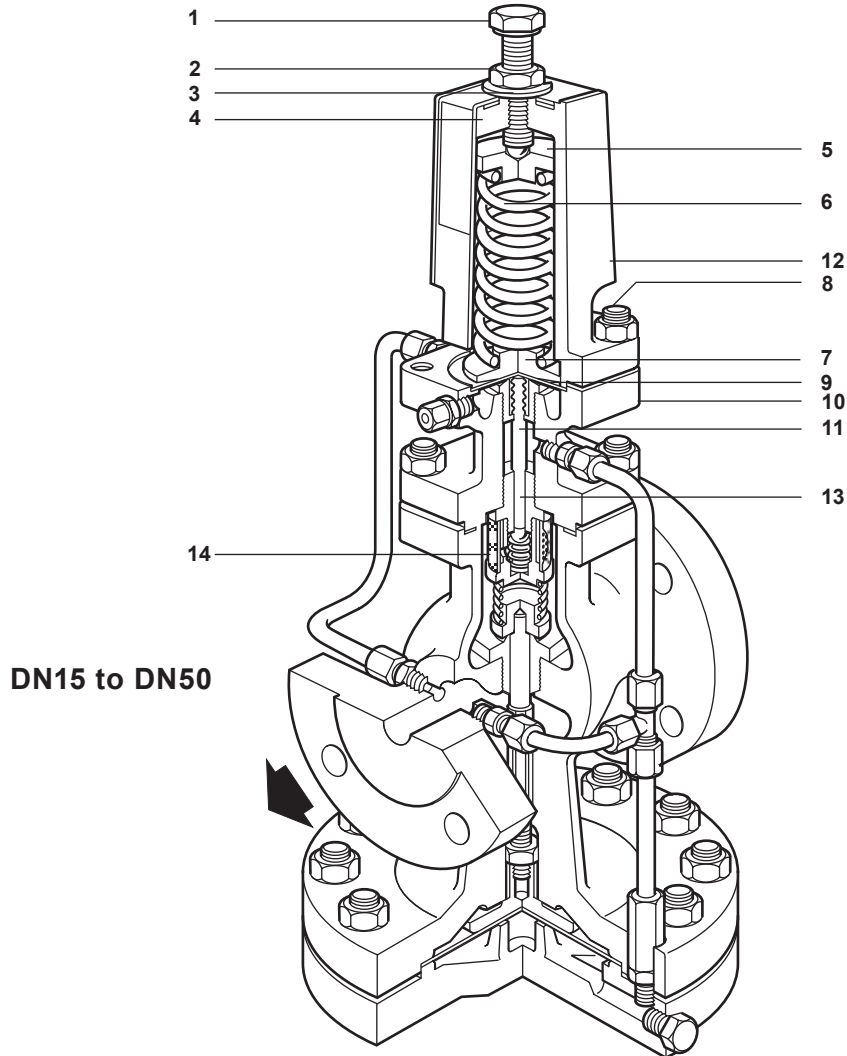

No.	Part	Material	
1	Adjustment screw	Stainless steel	BS 6105 A4/80
2	Adjustment lock-nut	Stainless steel	BS 6105 A4/80
3	Washer	Stainless steel	BS 1449 304 S16
4	Spring housing	Stainless steel	DIN 3100 316 C12
5	Top spring plate	Stainless steel	BS 970 431 S29
6	Pressure adjustment spring	Stainless steel	BS 2056 302 S25
7	Bottom spring plate	Stainless steel	BS 970 431 S29
8	Spring housing	Securing nuts	Stainless steel BS 6105 A4/80
		Securing studs	Stainless steel BS 6105 A4/80
			DN15 to DN50 M10 x 30 mm
9	Pilot diaphragm	Stainless steel	BS 1449 316 S31
10	Pilot valve housing	Stainless steel	BS 3100 316 C12
11	Pilot valve plunger	Stainless steel	BS 970 431 S29
12	Spring housing cover	Stainless steel	BS 1449 304 S12
13	Pilot valve and seat unit	Stainless steel	BS 970 431 S29
14	Internal strainer	Stainless steel	BS 1449 304 S16

Materials continued on the next page

**Materials (continued)**

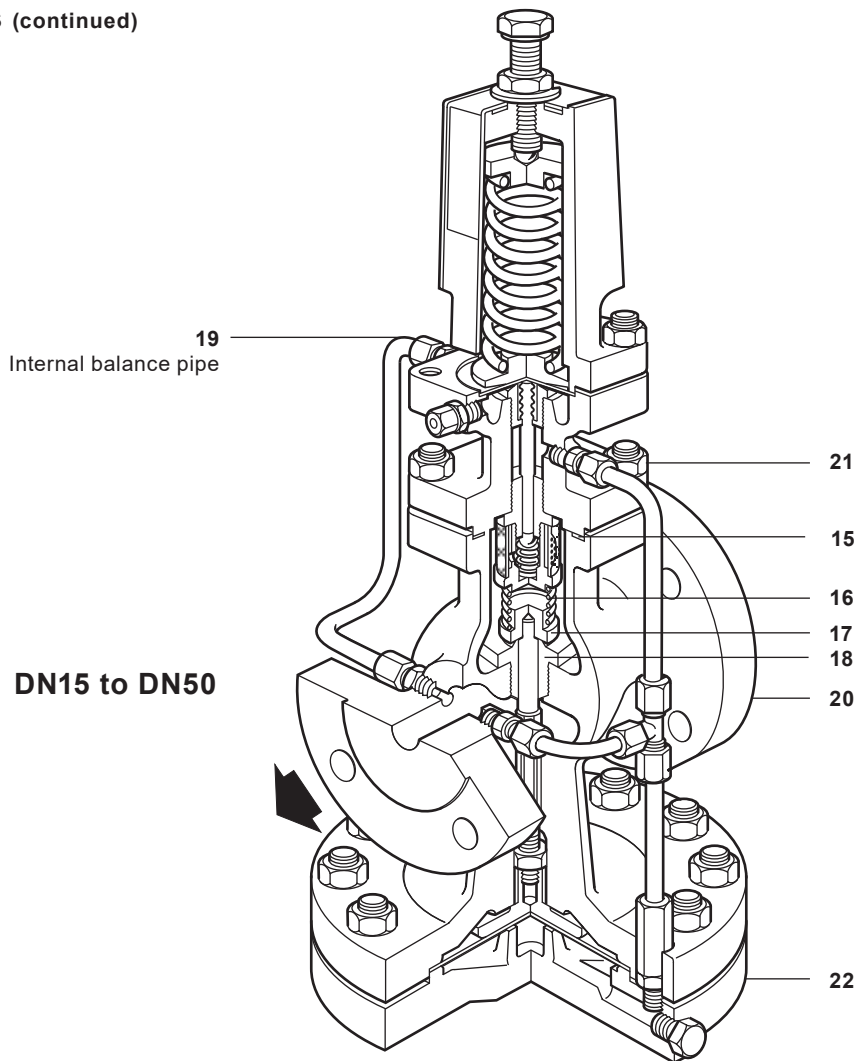

No.	Part	Material		
15	Body gasket	Stainless steel reinforced exfoliated graphite		
16	Main valve return spring	Stainless steel	BS 2056 302 S25	
17	Main valve	Stainless steel	BS 970 431 S29	
18	Main valve seat	Stainless steel	BS 970 431 S29	
19	Balance pipe assembly	Stainless steel	BS 3605 304 S14	
20	Main valve body	Stainless steel	BS 3100 316 C12	
21	Pilot valve housing	Securing nuts	Stainless steel BS 6105 A4/80	
		Securing studs	Stainless steel BS 6105 A4/80	
			DN15 and DN20	M10 x 25 mm
			DN25 to DN50	M12 x 30 mm
			DN80	M12 x 40 mm
22	Main diaphragm chamber	Cast stainless steel	BS 3100 316 C12	

**Materials continued on the next page**

**Materials (continued)**

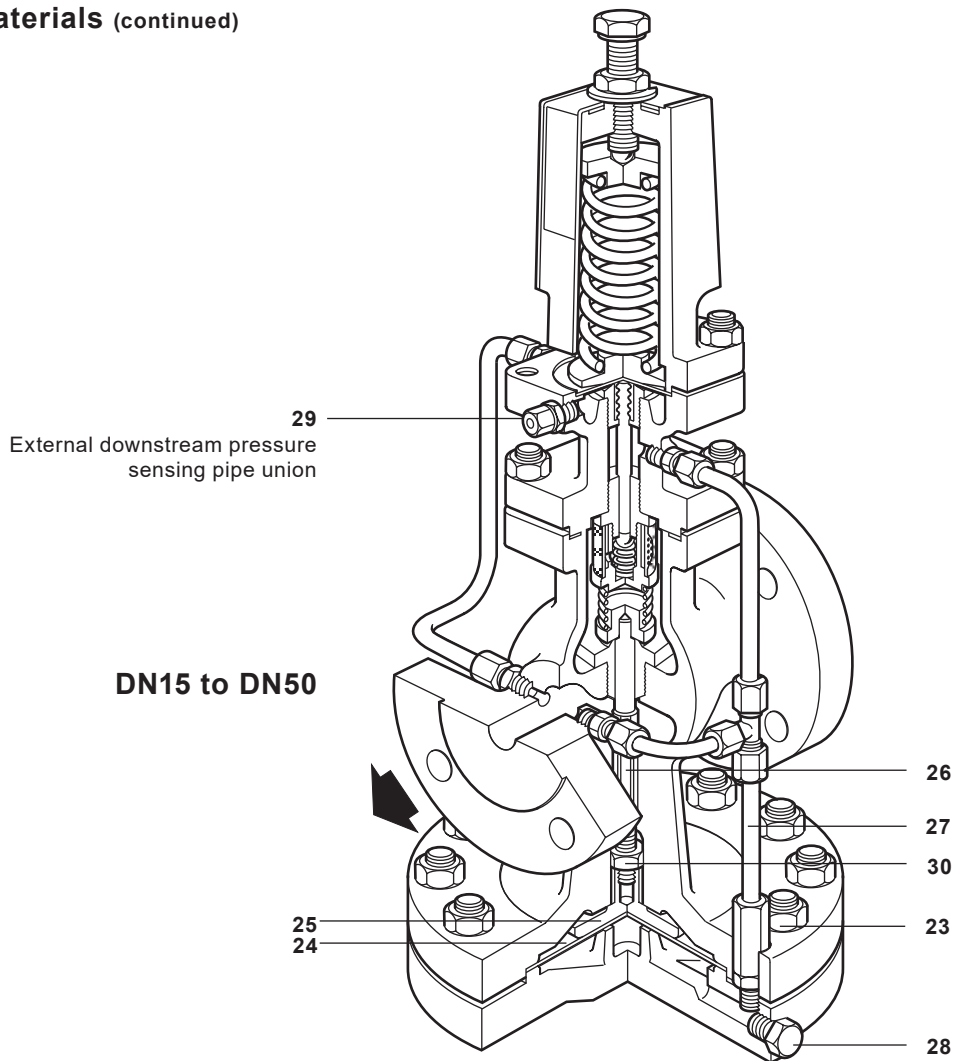

No.	Part	Material
	Securing nuts	Stainless steel BS 3692 Gr. 8
		Stainless steel BS 6105 A4/80
23	Main diaphragm	DN15 and DN20 M12 x 50 mm
		Securing bolts DN25 and DN32 M12 x 60 mm
		DN40 and DN50 M12 x 65 mm
		DN80 M12 x 80 mm
24	Main diaphragms	Stainless steel BS 1449 316 S31
25	Main diaphragm plate	Stainless steel BS 970 431 S29
26	Pushrod	Stainless steel BS 970 431 S29
27	Control pipe assembly	Stainless steel BS 3605 304 S14
28	Plug 1/8" BSP	Stainless steel BS 970 431 S29
29	Pressure pipe union	Stainless steel BS 970 316 S31
30	Lock-nut	Stainless steel BS 6105 A4/80

**Materials continued on the next page**

**Materials** (continued)

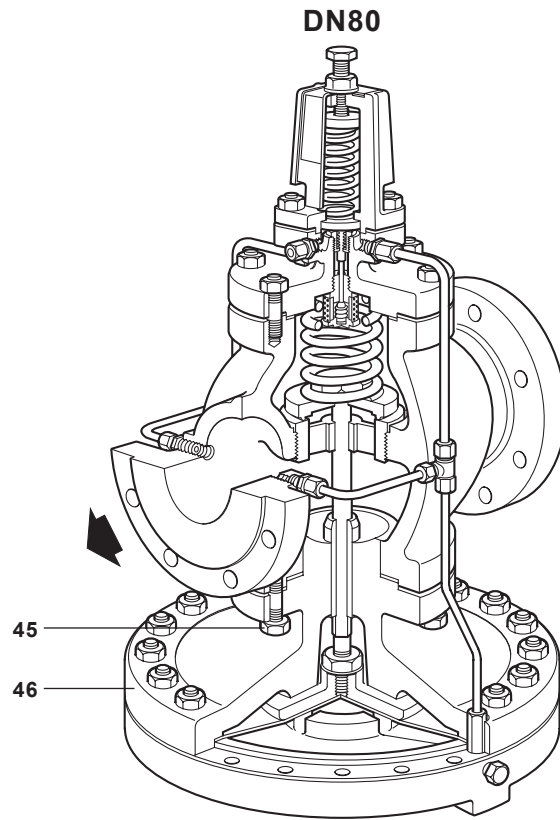

No.	Part	Material	
	Body nuts	Stainless steel	BS 3692 Gr. 8
45	Body studs	Stainless steel	BS 6105 A4/80
		DN80 only	M12 x 40 mm
46	Upper main diaphragm chamber	Stainless steel	BS 3100 316 C12

**Dimensions/weights (approximate) in mm and kg**

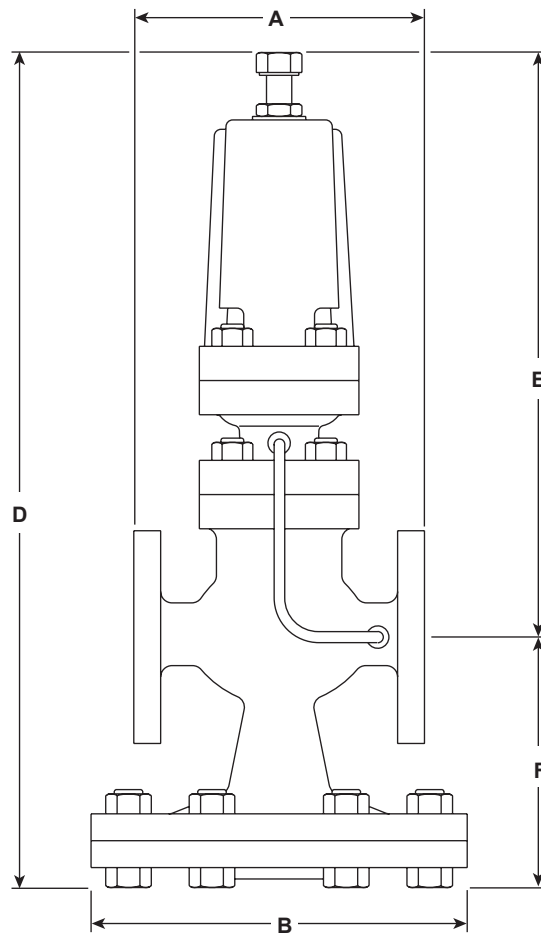

	EN 1092 PN40	ASME 300	ASME 150	BS 10 Table J					
Sizes	A	A	A	A	B	D	E	F	Weight
DN15 LC	130	130	122	130	175	405	277	128	15
DN15	130	130	122	130	175	405	277	128	15
DN20	150	150	142	150	175	405	277	128	16
DN25	160	160	156	164	216	440	288	152	23
DN32	180	183	176	184	216	440	288	152	25
DN40	200	209	200	209	280	490	305	185	40
DN50	230	236	230	243	280	490	305	185	42
DN80	310	319	310	325	350	580	322	258	103

## Steam capacities chart

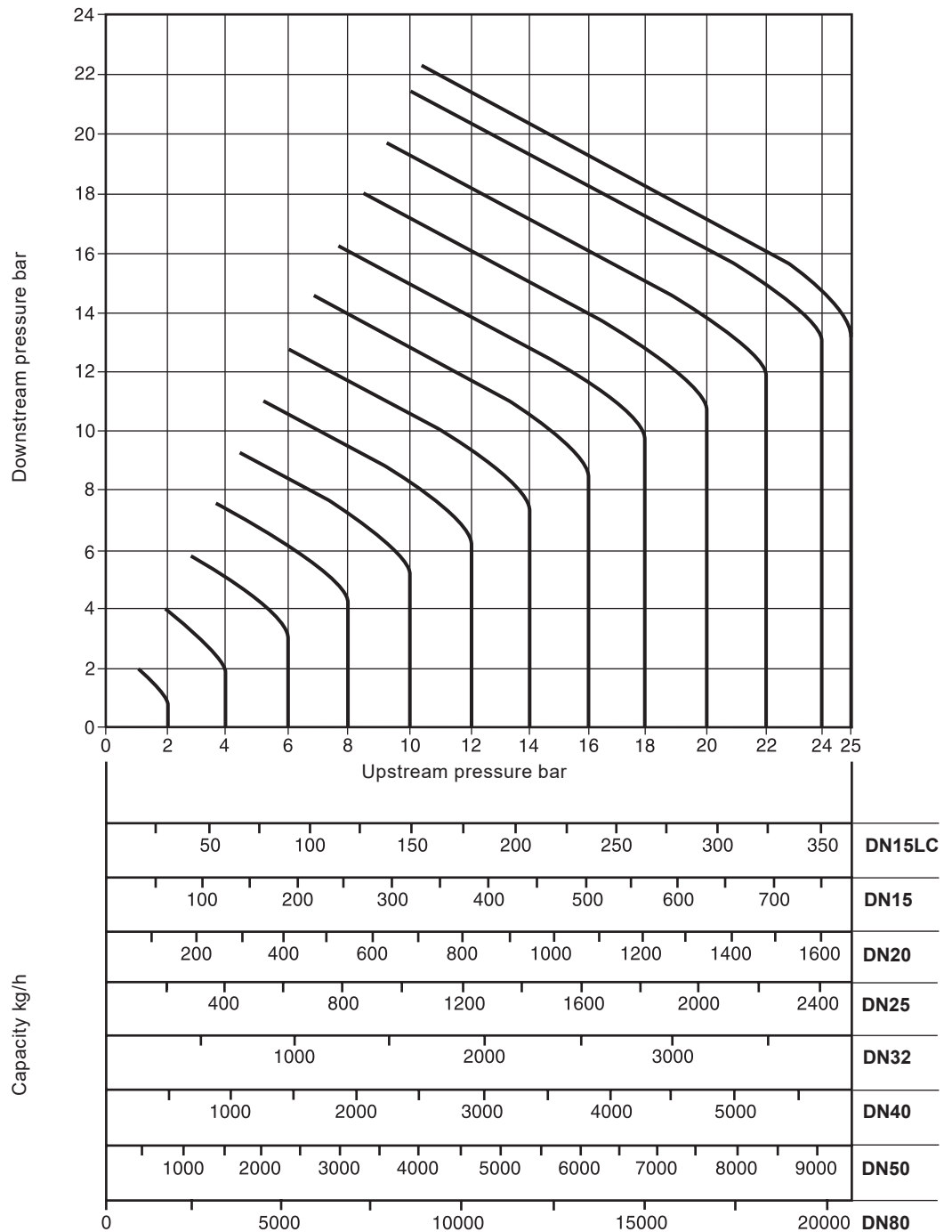

### Note

The capacities quoted above are based on valves fitted with an external pressure sensing pipe. Reliance on the internal balance pipe will mean that capacities may be reduced. In the case of low downstream pressure this reduction could be up to 30% of the valve capacity.

### How to use the chart

#### Saturated steam

A valve is required to pass 600 kg/h reducing from 6 bar to 4 bar. Find the point at which the curved 6 bar upstream pressure line crosses the horizontal 4 bar downstream pressure line. A perpendicular dropped from this point gives the capacities of all DP sizes under these conditions. A DN32 valve, is the smallest size which will carry the required load.

#### Superheated steam

Because of the higher specific volume of superheated steam a correction factor must be applied to the figure obtained from the chart above. For 55 °C of superheat the factor is 0.95 and for 100 °C of superheat the factor is 0.9.

Using the example given for saturated steam, the DN32 valve would pass  $740 \times 0.95 = 703$  kg/h if the steam had 55 °C of superheat. It is still big enough to pass the required load of 600 kg/h.



## Compressed air capacities chart

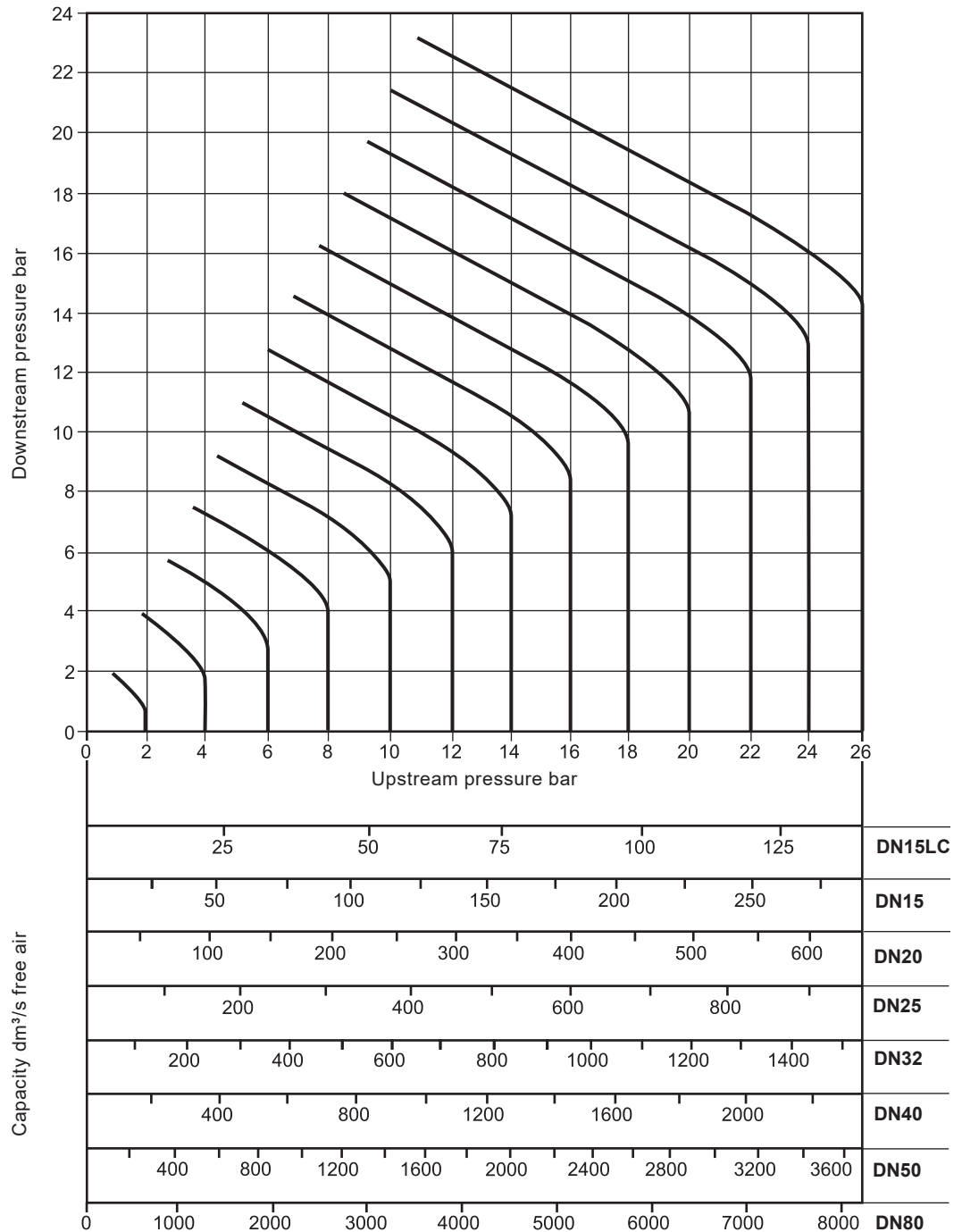

### How to use the chart

Capacities are given in cubic decimetres of free air per second ( $\text{dm}^3/\text{s}$ ). The use of the capacity chart can be best explained by an example. Required, a valve to pass  $100 \text{ dm}^3/\text{s}$  of free air reducing from 12 bar to 8 bar.

Find the point at which the curved 12 bar upstream pressure line crosses the horizontal 8 bar downstream pressure line. A perpendicular dropped from this point shows that whereas a DN15LC valve will only pass  $57 \text{ dm}^3/\text{s}$  and is therefore not large enough, a DN15 valve will pass approximately  $120 \text{ dm}^3/\text{s}$  under these conditions and is the correct valve size to choose.

### Safety information, installation and maintenance

For full details see the Installation and Maintenance Instructions (IM-P006-07) supplied with the product.

**Installation note:** The valve should be installed in a horizontal pipeline with the direction of flow as indicated by the arrow on the valve body.

### How to order

**Example:** 1 off Spirax Sarco DN32 DP163 pilot operated pressure reducing valve fitted with a red pressure adjustment spring and having flanged EN 1092 PN25 connections.

## Spare parts

### Available spares

Maintenance kit

A stand-by set of spares for general maintenance purposes and covers all spares marked\*

* Main diaphragm	(2 off)			<b>A</b>
* Pilot diaphragm	(2 off)			<b>B</b>
Pilot valve seal assembly				<b>C</b>
* Pilot valve and plunger assembly				<b>D, E</b>
Main valve assembly				<b>F, H</b>
* Main valve return spring				<b>G</b>
	Red	DP163 and DP163G	0.2 to 17 bar	
Pressure adjustment spring	Grey	DP163 and DP163G	16 to 21 bar	<b>J</b>
	Yellow	DP163Y and DP163G	0.2 to 3 bar	
* Control pipe assembly				<b>K</b>
* Balance pipe assembly				<b>M, N</b>
* Body gasket		(packet of 3)		<b>O</b>
Set of spring housing securing studs and nuts	(set of 4)			<b>P</b>
Set of pilot valve housing securing studs and nuts	(set of 4)			<b>Q</b>
	(set of 10)	DN15 and DN20		
Set of diaphragm chamber securing bolts and nuts	(set of 12)	DN25 and DN32		<b>R</b>
	(set of 16)	DN40 and DN50		
	(set of 20)	DN80		
Set of main body studs and nuts (DN80)	(set of 6)			<b>T</b>
Pushrod and main diaphragm plate assembly				<b>V</b>

### How to order spares

Always order spares by using the description given in the column headed 'Available spares' and state the size and type of pressure reducing valve.

**Example:** 1 - Main valve assembly for a Spirax Sarco DN15 DP163 pressure reducing valve.

**How to fit** - See the Installation and Maintenance Instructions supplied with the pressure reducing valve. Further copies are available on request.

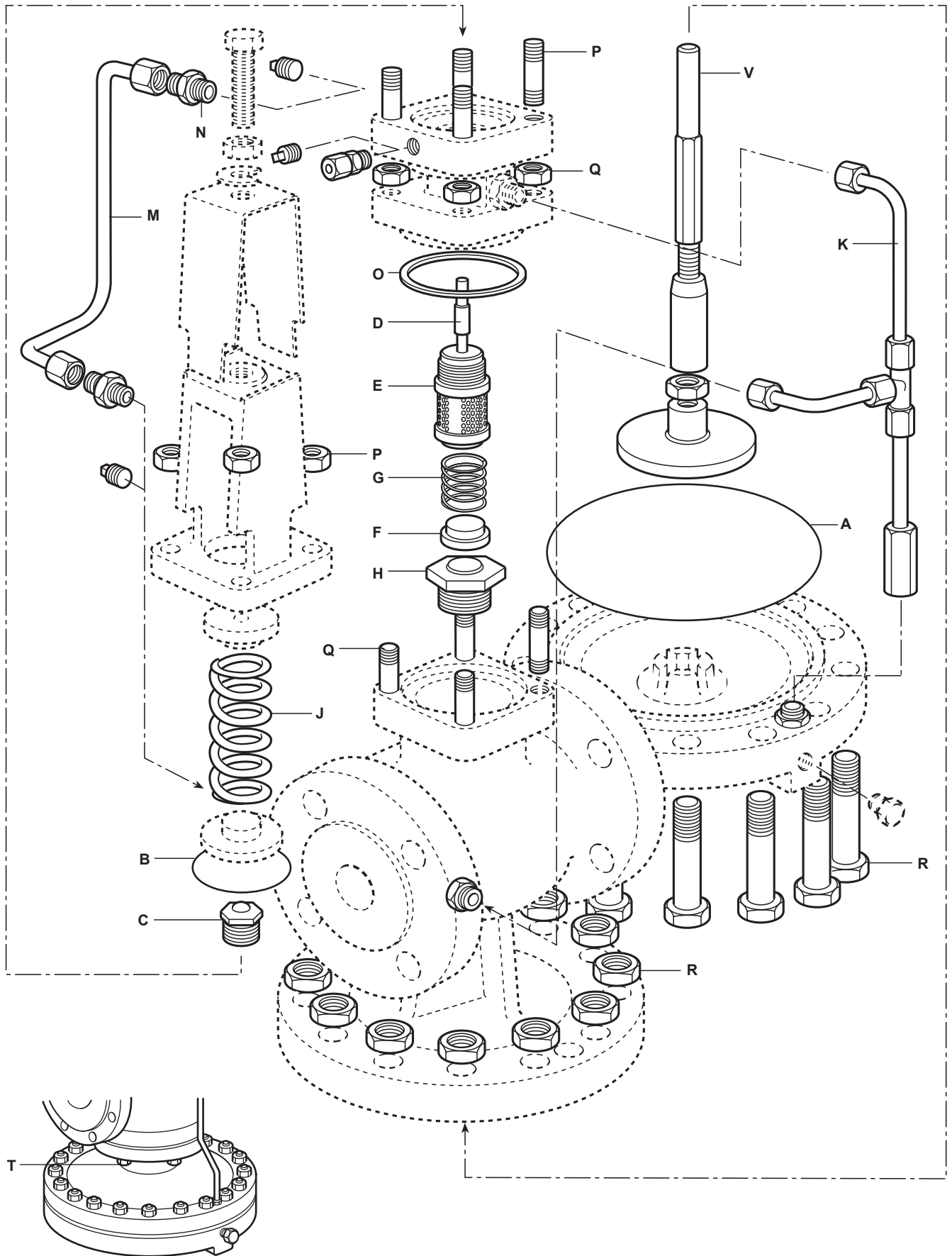

Arrangement of main diaphragm chamber DN80 size only.

## Interchangeability of spares

The following table shows how in certain sizes some parts are interchangeable. For example in the line headed 'Main diaphragm' the diaphragm used in the following sizes: DN15LC, DN15 and DN20 is common to these sizes by the letter 'a'. The letter 'b' indicates that sizes DN25 and DN32 use one common diaphragm.

Some parts, particularly pilot and main valve assemblies are specific to particular models e.g 'DP163G'. Interchangeability is therefore restricted to model type for some parts.

Please note for storage purposes: The spare parts marked † are not of the same material as those for the DP143, consequently they are not compatible for interchangeability.

Size	DN15LC	** DN15	DN20	DN25	DN32	DN40	DN50	DN80
Main diaphragm	a	a	a	b	b	c	c	d
Pilot diaphragm	a	a	a	a	a	a	a	a
Pilot valve seal assembly	a	a	a	a	a	a	a	a
Pilot valve and plunger assembly	a	a	a	a	a	a	a	a
Main valve assembly	a	b	c	d	e	f	g	h
Main valve return spring	a	a	a	b	b	c	c	d
Pressure adjustment spring	a	a	a	a	a	a	a	a
Control pipe assembly	† a	a	b	c	d	e	f	g
Balance pipe assembly	† a	a	b	c	d	e	f	g
Body gasket	† a	a	a	b	b	c	c	d
Set of spring housing securing studs and nuts	† a	a	a	a	a	a	a	a
Set of pilot valve housing securing studs and nuts	† a	a	a	b	b	c	c	d
Set of diaphragm chamber securing bolts and nuts	† a	a	a	b	b	c	c	d
Set of main body studs and nuts	† -	-	-	-	-	-	-	a

**\*\* Not available for the DP163G**