



M Series Condensate Recovery Unit

Description

The Spirax Sarco M series is a compact packaged condensate recovery unit designed for relatively small loads. It comprises a vertical receiver with single close-coupled motor pump and control gear pre-wired and ready for use.

Standards

This product fully complies with the requirements of:

- Machinery Directive (MD) 2006/42/EC.
- Low Voltage Directive (LVD) 2014/35/EU.
- Electromagnetic Compatibility Devices Directive (ECDD) 2014/30/EU.

This product is not a pressurised vessel and therefore does not need to comply with the Pressure Equipment Directive (PED).

Certification

This product is available with a Typical Test Report and a certificate of conformity to EN 10204 2.1.

Note: All certification/inspection requirements must be stated at the time of order placement.

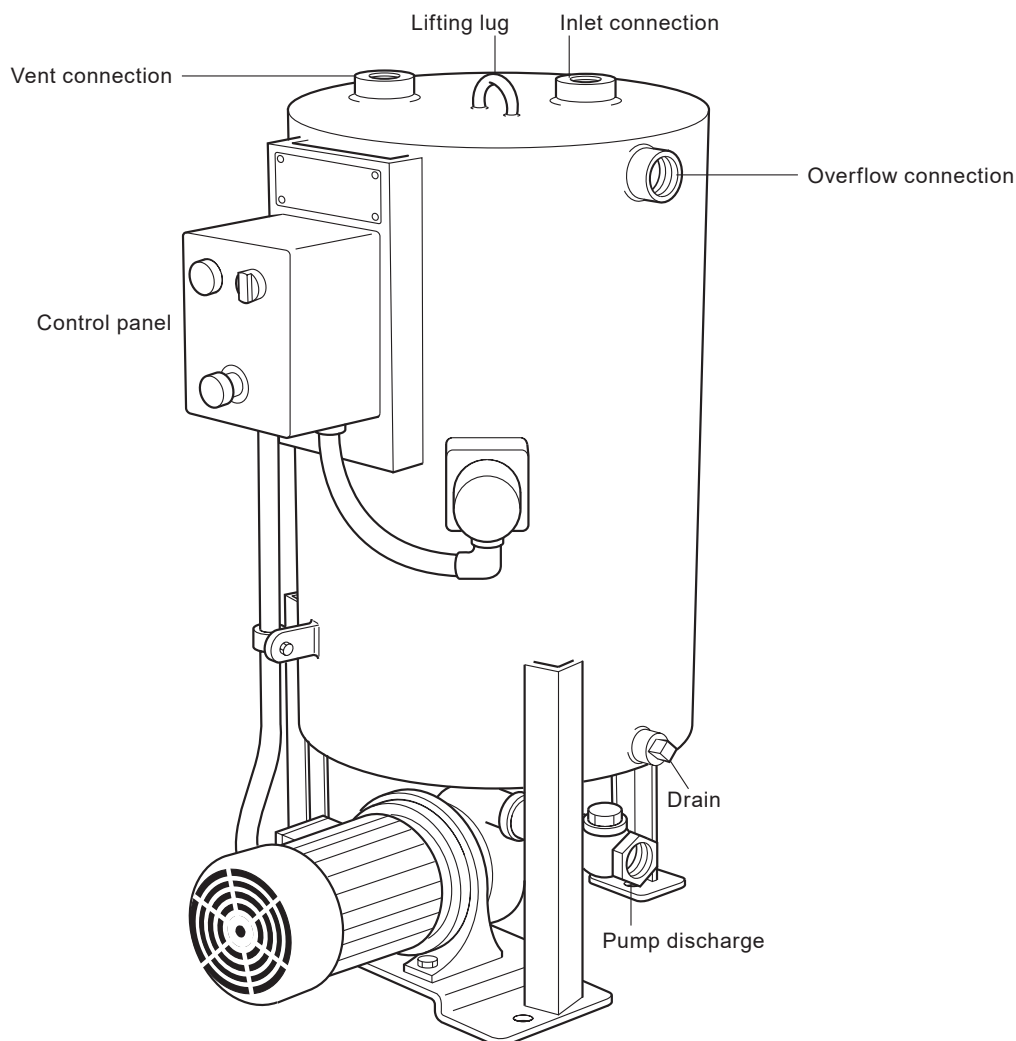

Construction

Receiver

Steel construction, hot dip galvanised. Designed for vented operation but pressure tested to 2.1 bar. Alternatively a mild steel receiver painted externally with two coats of primer is available upon request.

Pumps

Pumps are designed to operate under conditions of extremely low NPSH. Close coupled motor pump with cast iron casing and bronze impeller. Stainless steel shaft and Crane mechanical seal.

3 400 or 2 800 rpm motor suitable for 380 - 440 volt 3 phase 50 Hz or 60 Hz supplies. TEFV IP55 enclosure with Class 'F' insulation utilizing Class 'B' temperature rise only.

Control gear

Float operated magnetic level switch pre-wired to a control panel housed in plastic control gear with the enclosure mounted on a stand-off bracket. Enclosure houses contactor starter with overload and single phasing protection. A rotary 'Hand/Off/Auto' selector provides manual control for test or maintenance. The control gear enclosure is pre-wired in a flexible conduit to the motor pump terminal box.

Warning: The customer electrical supply must contain fuse protection.

Electrical details

Unit	M0207	M2107	M2111
kW rating	0.75	0.75	1.10

Installation

The pump suction pipework incorporates a resilient coupling, avoiding expansion stresses and facilitating pump removal.

A 1" BSP bronze non-return valve is fitted to the pump delivery.

Installation requires only connection of the inlet, vent, overflow and discharge pipework, and wiring between the customers supply isolator and the control gear enclosure. With the selector turned to 'Auto' the unit operates to match demand with no further attention.

Note: It is recommended that a valve should be fitted in the delivery pipework adjacent to the unit. Should the system head be less than the unit head, the valve may then be adjusted to increase the system head, reducing possible cavitation and noise.

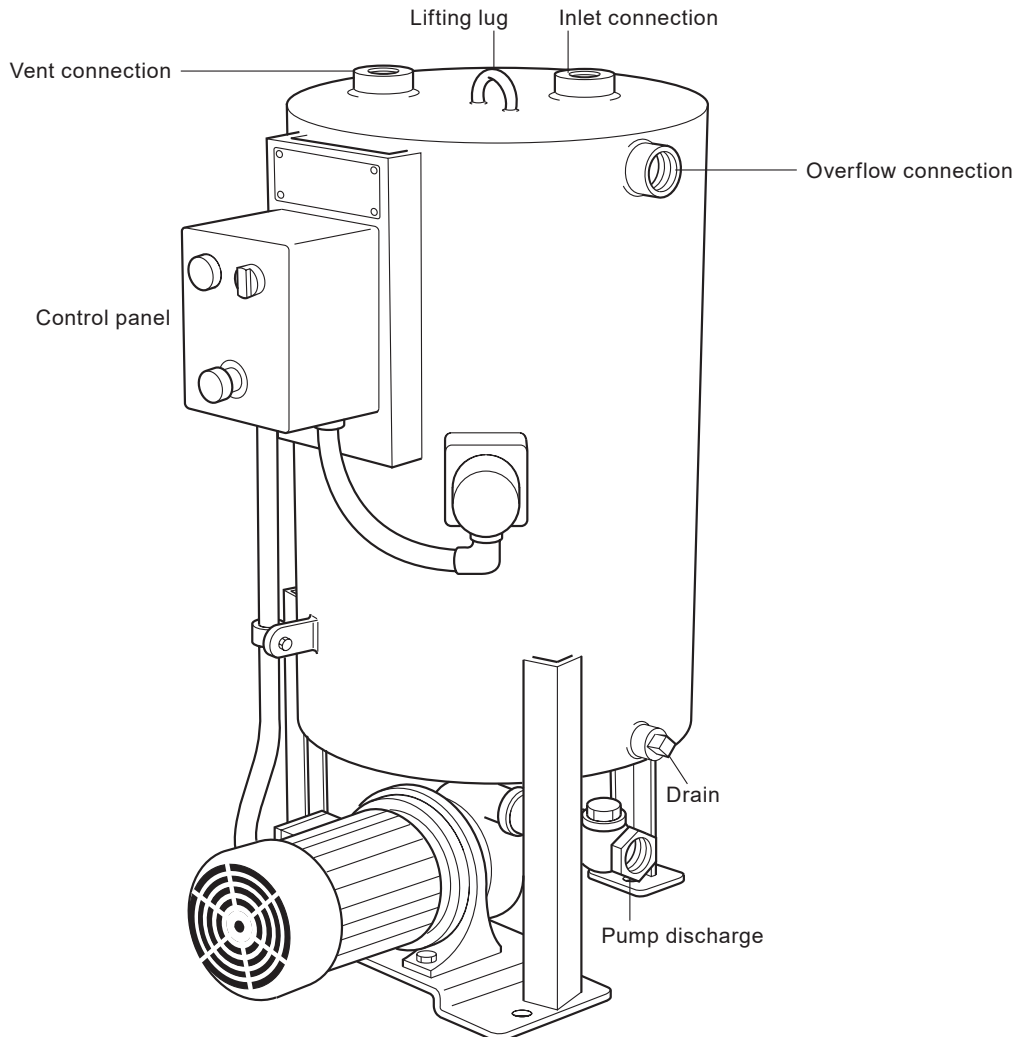

Dimensions/weights in mm and kg

(Note: these figures are for guidance only and not to be used for design purposes)

Unit	A	B	C	D	E	F	G	H	J	K	L	M	N	P	Q	Weight
M0207	1075	240	260	665	1005	215	320	150	25	380	200	220	175	220	700	95.0
M2107	1075	240	260	665	1005	235	320	150	25	380	200	220	175	220	700	95.0
M2111	1075	240	260	665	1005	235	320	150	25	380	200	220	175	220	700	95.0

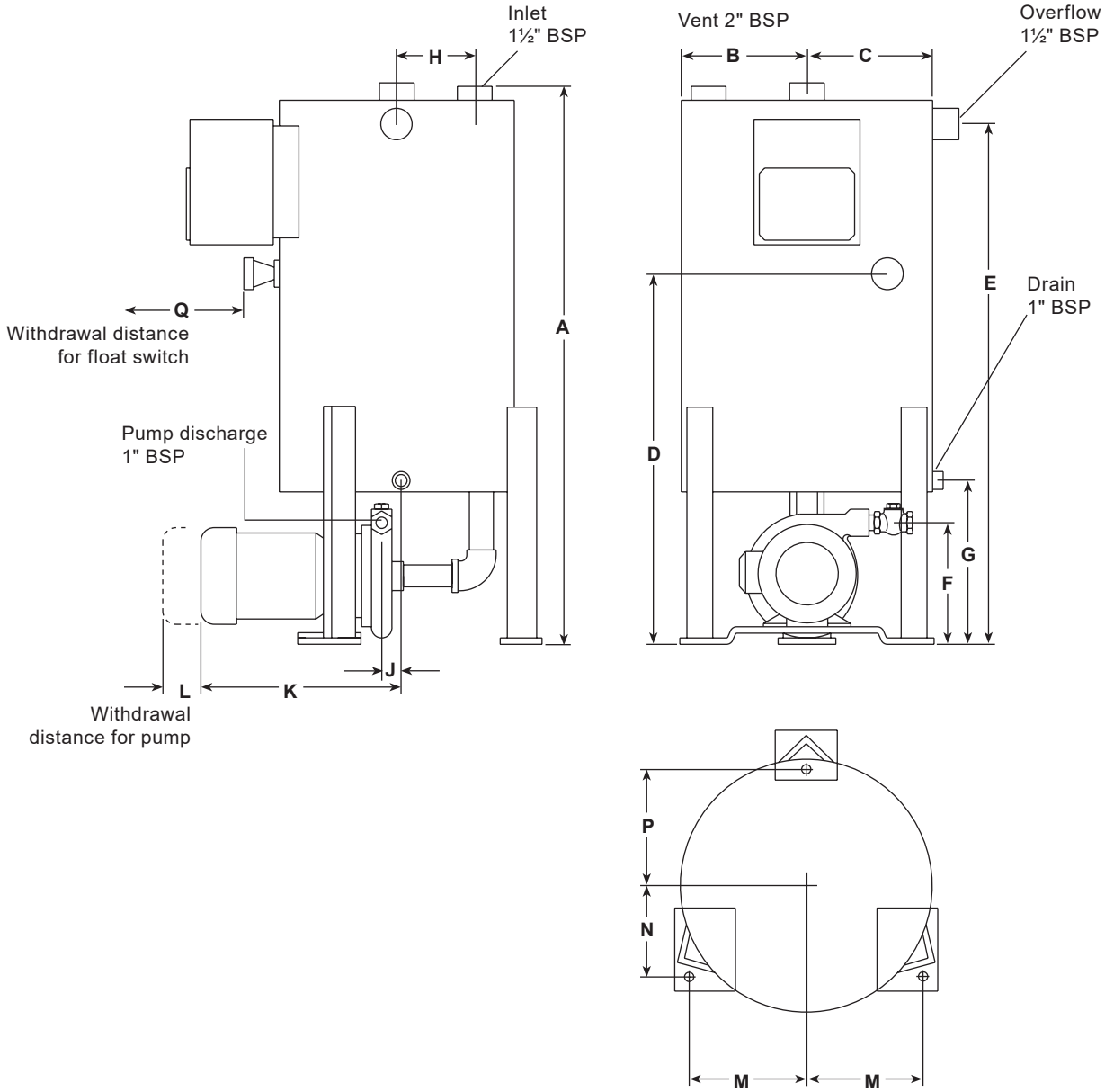

Sizing charts

