

## SV60

# Safety Valve Replacement Parts

### Fitting Instructions

---

---

### Warning

Resetting or refurbishment of Spirax Sarco safety valves must only be carried out by authorised, competent persons.

### Safety Warning

Do not attempt to dismantle the valve without first releasing the compression on the spring.

**For valves containing a Viton/FPM elastomer seal**  
If the valve has been subjected to a temperature approaching 315 °C the Viton/FPM may have decomposed and formed hydrofluoric acid.

Avoid skin contact and inhalation of fumes as this acid causes deep burns and damage to the respiratory system.

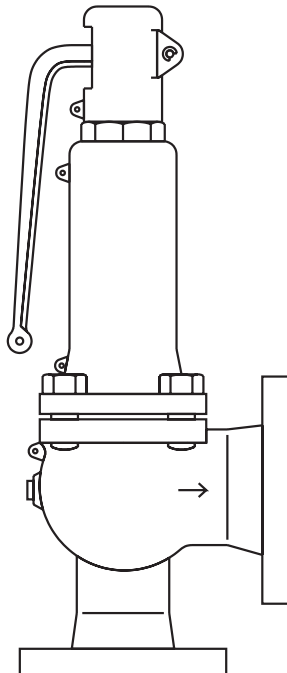

## 1. To change the cap (item 4):

- a) Remove the sealing wire, and one circlip (20) from the pivot pin (19).
- b) Withdraw the pivot pin and remove the lever (18). For closed cap or packed lever arrangements simply unscrew the cap from the spring housing (lifting the lever such that the cam clears the collar (17) if necessary).
- c) For standard cap arrangements, slacken the cap locking bolt (16) and unscrew the cap.
- d) Reassemble in reverse sequence observing the recommended tightening torques given in Table 1.

## 2. Replacement of lever packing (item 30):

- a) Remove the cap as described in Section 1.
- b) Remove the lever pin (19) and lever (18).
- c) Unscrew the gland nut (31) and remove bush (30).
- d) Withdraw the lever spindle (27) and packing rings (30 (4 off)).
- e) It is advisable to note the orientation of the pin and cam (28) to ensure the parts are reassembled in the correct position. The cam will now be loose.
- f) Refit the lever stem and packing rings.
- g) Replace the packing rings individually using the bush to press them into position.
- h) Refit the bush and gland nut then tighten until compression on gland seal is sufficient to seal against spindle.  
**Note:** Replace gasket (35) on reassembly.
- i) Refit the lever and lever pin.

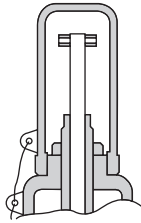

Gas tight cap

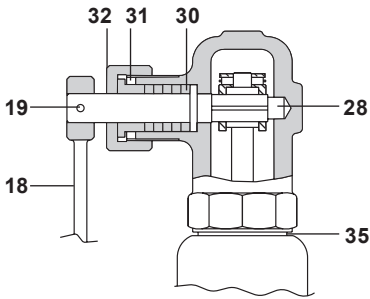

Packed easing lever

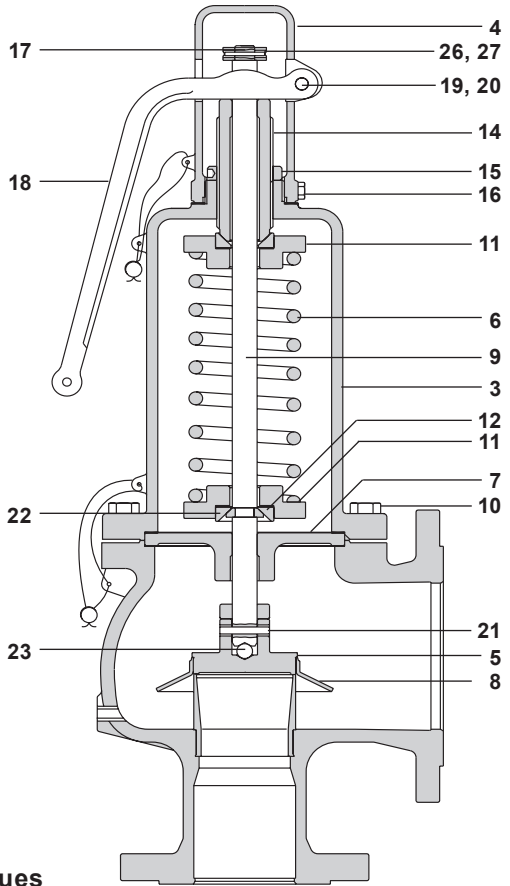

**Table 1**  
Recommended tightening torques

Valve size	Lever housing set screw (item 16)		Adjuster lock-nut (item 15)		Body bolts (item 10)		
	A/F (mm)	Torque ( $\pm 1$ N m)	A/F (mm)	Torque ( $\pm 5$ N m)	Number off	A/F (mm)	Torque (+3 -0 N m)
DN20	10	4	30	55	4	17	21
DN25	10	4	30	55	4	19	36
DN32	10	4	30	55	4	19	36
DN40	10	4	41	55	4	22	52
DN50	10	4	41	55	4	22	52
DN65	13	10	46	60	6	19	36
DN80	13	10	70	60	8	22	52
DN100	13	10	70	60	8	22	52
DN125	13	10	85	70	8	24	90
DN150	13	10	85	70	12	24	90

### 3. To change the spring (item 6):

- a) Remove the cap as described in Section 1.
- b) Remove the collar circlip (27), collar pin (26) and the collar (17).
- c) Slacken the lock-nut (15) and wind the spring adjustment screw (14) anticlockwise to release the spring pressure gripping the spindle (9) to ensure it does not rotate.
- d) Loosen the body bolts (10) and remove the bonnet (3).
- e) Remove the spring (6) and spring plates (11) and replace with the new spring and spring plates.
- f) Reassemble in reverse sequence observing the recommended tightening torques given in Table 1.

### 4. To replace the disc assembly (items 5 and 8):

- a) Follow the procedure as described in Section 3.
- b) After the spring and spring plates have been removed the spindle assembly and guide plate can be lifted from the body being careful not to lose the retaining rings (12 and 22).
- c) The retaining rings should be removed and the spindle guide (7).
- d) Remove the disc assembly from the spindle by tapping out the spindle pin (21). Be careful not to lose the spindle ball (23) which allows the disc to articulate.
- e) Fit new disc (5 and 8) to the spindle (9) ensuring the spindle ball (23) is located between these items and refit the spindle pin (21).
- f) Reassemble in reverse sequence ensuring the spindle guide is fitted with the spigot facing downwards.

### Warning:

Disc/skirt assemblies (items 5 and 8) are non-serviceable and must not be repaired/rectified under any circumstances. In the event of failure, damaged assemblies must be replaced with new assemblies or the valve repaired by an approved Spirax Sarco repair specialist.

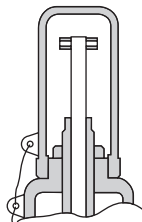

Gas tight cap

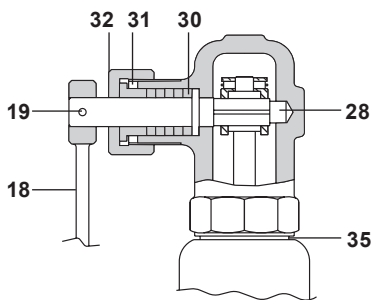

Packed easing lever

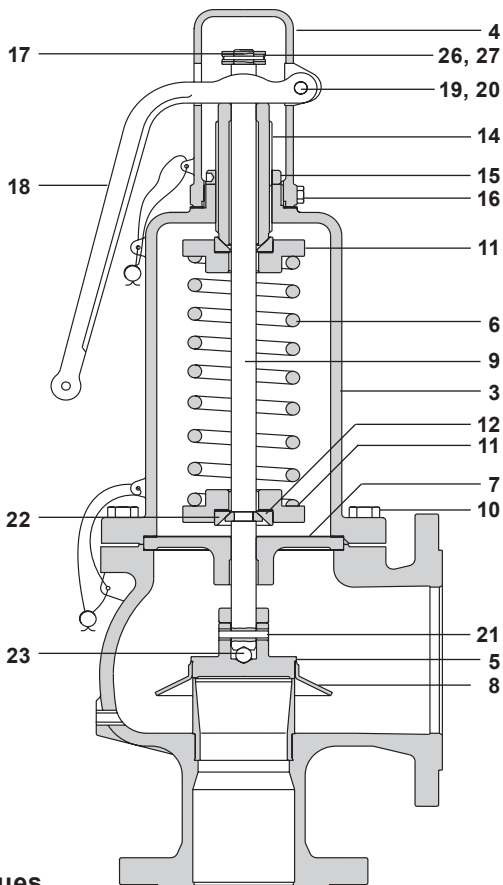
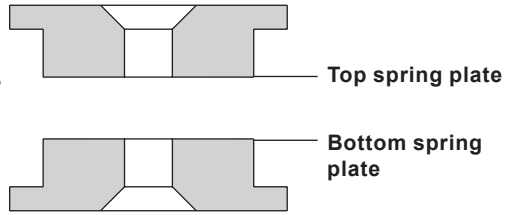

**Table 1**  
Recommended tightening torques

Valve size	Lever housing set screw (item 16)		Adjuster lock-nut (item 15)		Body bolts (item 10)		
	A/F (mm)	Torque ( $\pm 1$ N m)	A/F (mm)	Torque ( $\pm 5$ N m)	Number off	A/F (mm)	Torque (+3 -0 N m)
DN20	10	4	30	55	4	17	21
DN25	10	4	30	55	4	19	36
DN32	10	4	30	55	4	19	36
DN40	10	4	41	55	4	22	52
DN50	10	4	41	55	4	22	52
DN65	13	10	46	60	6	19	36
DN80	13	10	70	60	8	22	52
DN100	13	10	70	60	8	22	52
DN125	13	10	85	70	8	24	90
DN150	13	10	85	70	12	24	90

## 5. Spring plate types:

Spring plate -  
Type 1



Spring plate -  
Type 2

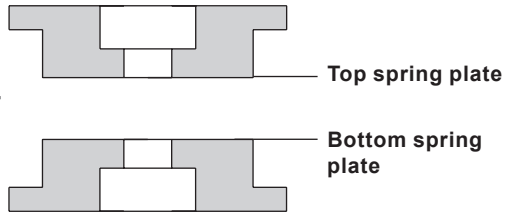

Spring plate -  
Type 3

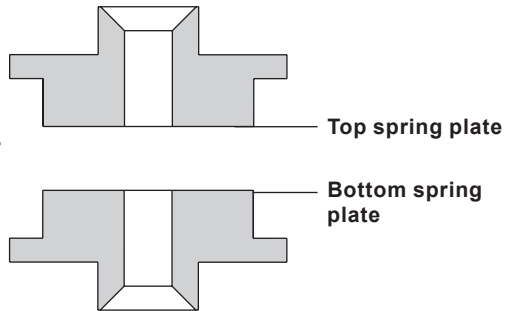

## 6. SV60 spring identification

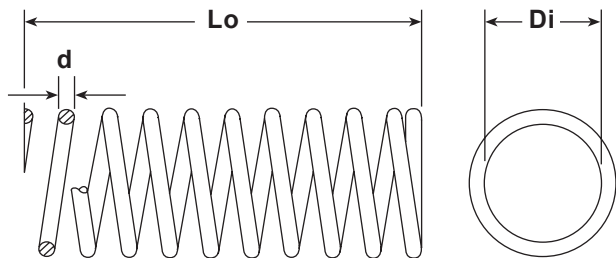

## 6.1 Spring identification table

Valve size	Spring reference	Set pressure range, bar g from to		Inside Ø Di (mm)	Wire Ø d (mm)	Free length Lo (mm)	Total No. of coils	Spring plate type
DN20 x DN32	RH-A-700	0.20	1.30	27.6	2.45	90.0	14.66	1
	RH-A-703	1.30	1.70	31.8	3.1		10.36	1
	RH-A-704	1.70	2.05	31.0	3.5		12.10	1
	RH-A-706	2.05	2.70	31.4	3.8		11.23	1
	RH-A-708	2.70	3.75	35.0	4.5		10.54	1
	RH-A-709	3.75	4.50	34.5	4.5		9.63	1
	RH-A-710	4.50	6.60	37.4	4.8		8.75	1
	RH-A-711	6.60	9.60	39.6	5.2		8.20	1
	RH-A-714	9.60	16.6	38.8	5.6		8.11	1
	RH-A-790	16.60	26.6	40.5	5.5		6.41	1
	RH-A-791	26.60	40.0	40.3	6.1		6.33	1
DN25 x DN40	RH-A-600	0.20	0.70	43.5	4.0	130.0	17.53	1
	RH-A-602	0.70	1.45	41.0	5.0		14.48	1
	RH-A-604	1.45	2.20	42.5	6.0		13.01	1
	RH-A-607	2.20	2.80	37.0	6.0		12.52	1
	RH-A-690	2.80	3.40	37.4	6.3		12.44	1
	RH-A-608	3.40	4.10	37.0	6.5		12.55	1
	RH-A-691	4.10	6.30	38.4	6.8		11.95	1
	RH-A-612	6.30	9.70	36.0	7.0		11.73	1
	RH-A-614	9.70	15.20	36.5	7.5		10.95	1
	RH-A-616	15.20	20.70	37.5	8.0		10.37	1
	RH-A-618	20.70	28.00	38.0	8.3		9.48	1
	RH-A-620	28.00	36.00	36.9	8.7		8.95	1
RH-A-624	36.00	40.00	48.6	10.2	7.61	1		
DN32 x DN50	RH-A-601	0.20	0.60	44.0	4.5	130.0	16.00	1
	RH-A-602	0.60	1.30	41.0	5.0		14.48	1
	RH-A-604	1.30	1.95	42.5	6.0		13.01	1
	RH-A-607	1.95	2.70	37.0	6.0		12.52	1
	RH-A-608	2.70	3.80	37.0	6.5		12.50	1
	RH-A-610	3.80	5.60	39.0	7.0		11.53	1
	RH-A-692	5.60	13.60	40.7	7.4		9.38	1
	RH-A-693	13.60	19.60	39.8	8.1		9.14	1
	RH-A-619	19.60	29.10	50.8	9.6		7.63	1
	RH-A-622	29.10	40.00	54.2	10.4	6.88	1	

## 6.1 Spring identification table (continued)

Valve size	Spring reference	Set pressure range, bar g		Inside Ø Di (mm)	Wire Ø d (mm)	Free length Lo (mm)	Total No. of coils	Spring plate type
		from	to					
DN40 x DN65	RH-A-500	0.20	0.65	63.4	6.0	175.0	17.06	3
	RH-A-502	0.65	1.20	55.0	7.0		15.06	1
	RH-A-508	1.20	1.80	59.0	8.5		12.97	1
	RH-A-515	1.80	2.45	58.0	9.5		12.25	1
	RH-A-518	2.45	3.10	54.5	9.5		12.02	1
	RH-A-520	3.10	3.90	56.0	10.0		10.94	1
	RH-A-524	3.90	4.90	55.0	10.5		11.28	1
	RH-A-528	4.90	6.00	54.0	11.0		10.94	1
	RH-A-530	6.00	7.10	52.0	11.0		10.68	1
	RH-A-531	7.10	8.50	55.0	11.5		10.17	1
	RH-A-534	8.50	12.10	57.0	12.0		9.33	1
	RH-A-540	12.10	18.10	54.5	12.5		9.23	1
	RH-A-548	18.10	26.00	57.7	13.4		7.99	1
	RH-A-553	26.00	35.00	63.0	15.0		7.31	1
RH-A-556	35.00	40.00	55.0	15.0	8.18	1		
DN50 x DN80	RH-A-500	0.20	0.55	63.5	6.0	175.0	17.06	3
	RH-A-502	0.55	1.05	55.0	7.0		15.06	1
	RH-A-508	1.05	1.55	59.0	8.5		12.97	1
	RH-A-512	1.55	2.15	58.0	9.0		12.56	1
	RH-A-518	2.15	2.80	54.5	9.5		12.02	1
	RH-A-522	2.80	3.70	54.0	10.0		11.20	1
	RH-A-524	3.70	4.70	55.0	10.5		11.28	1
	RH-A-529	4.70	6.50	53.5	11.0		10.76	1
	RH-A-531	6.50	10.50	55.0	11.5		10.17	1
	RH-A-536	10.50	14.70	55.0	12.0		9.34	1
	RH-A-542	14.70	22.80	57.2	12.7		8.23	2
	RH-A-548	22.80	29.10	57.7	13.4		7.99	2
	RH-A-551	29.10	36.60	61.6	14.2		7.36	2
RH-A-553	36.60	40.00	63.0	15.0	7.31	2		



## 6.1 Spring identification table (continued)

Valve size	Spring reference	Set pressure range, bar g		Inside Ø Di (mm)	Wire Ø d (mm)	Free length Lo (mm)	Total No. of coils	Spring plate type
		from	to					
DN65 x DN100	RH-A-400	0.2	0.6	58.0	6.0	225.0	21.35	1
	RH-A-402	0.6	1.2	52.0	7.5		16.64	1
	RH-A-405	1.2	1.8	50.0	8.5		14.67	1
	RH-A-409	1.8	2.5	52.0	9.5		13.32	1
	RH-A-412	2.5	3.2	49.0	10.0		13.10	1
	RH-A-413	3.2	3.8	49.0	10.5		13.19	1
	RH-A-415	3.8	4.9	49.0	11.0		12.95	1
	RH-A-416	4.9	6.2	45.0	11.0		13.35	1
	RH-A-419	6.2	7.5	47.0	11.5		12.57	1
	RH-A-490	7.5	10.6	48.5	12.0		12.06	1
	RH-A-421	10.6	14.6	47.5	12.5		11.93	2
	RH-A-424	14.6	20.0	56.0	14.5		10.37	2
	RH-A-426	20.0	27.7	69.0	16.5		8.77	2
RH-A-430	27.7	32.0	65.0	17.0	8.82	2		
DN80 x DN125	RH-A-300	0.20	0.75	84.0	8.5	260.0	14.82	1
	RH-A-390	0.75	1.30	72.0	10.0		10.74	1
	RH-A-305	1.30	1.75	86.0	12.5		10.19	1
	RH-A-307	1.75	2.20	84.0	13.0		9.50	1
	RH-A-310	2.20	3.10	92.0	15.0		8.58	1
	RH-A-312	3.10	4.00	92.0	16.0		8.00	1
	RH-A-314	4.00	5.10	96.2	17.4		7.65	2
	RH-A-315	5.10	6.00	97.5	18.0		7.50	2
	RH-A-316	6.00	7.50	95.4	18.3		7.57	2
	RH-A-318	7.50	8.70	92.0	19.0		7.84	2
	RH-A-320	8.70	10.50	93.0	20.0		7.94	2
	RH-A-322	10.50	19.00	90.0	20.5		8.16	2
	RH-A-326	19.00	32.00	90.0	22.0		7.99	2

## 6.1 Spring identification table (continued)

Valve size	Spring reference	Set pressure range, bar g		Inside Ø Di (mm)	Wire Ø d (mm)	Free length Lo (mm)	Total No. of coils	Spring plate type
		from	to					
DN100 x DN150	RH-A-301	0.20	0.60	80.0	9.0	260.0	14.05	1
	RH-A-390	0.60	1.20	72.0	10.0		10.74	1
	RH-A-306	1.20	1.60	85.6	12.7		9.51	1
	RH-A-309	1.60	2.10	94.0	14.5		8.61	2
	RH-A-311	2.10	2.70	95.0	15.5		8.27	2
	RH-A-312	2.70	3.10	92.0	16.0		8.00	2
	RH-A-313	3.10	3.80	87.0	16.5		8.55	2
	RH-A-392	3.80	4.70	96.0	18.0		7.86	2
	RH-A-316	4.70	5.70	95.4	18.3		7.57	2
	RH-A-318	5.70	7.50	92.0	19.0		7.84	2
	RH-A-320	7.50	11.10	93.0	20.3		8.50	2
	RH-A-324	11.10	18.10	91.8	21.1		7.82	2
	RH-A-328	18.10	25.00	106.6	24.2		6.81	2
	DN125 x DN200	RH-A-200	0.20	0.75	119.0		12.0	315.0
RH-A-202		0.75	1.50	116.0	13.5	10.41	2	
RH-A-206		1.50	2.30	117.0	15.5	8.78	2	
RH-A-209		2.30	3.10	116.0	17.0	8.79	2	
RH-A-210		3.10	4.10	116.0	18.0	8.96	2	
RH-A-211		4.10	5.20	115.0	18.5	8.72	2	
RH-A-212		5.20	7.40	114.8	19.1	8.62	2	
RH-A-215		7.40	10.80	123.0	20.5	7.53	2	
RH-A-219		10.80	16.10	132.0	22.5	6.76	2	
RH-A-223		16.10	20.00	129.0	24.0	6.70	2	

## 6.1 Spring identification table (continued)

Valve size	Spring reference	Set pressure range, bar g		Inside Ø Di (mm)	Wire Ø d (mm)	Free length Lo (mm)	Total No. of coils	Spring plate type
		from	to					
DN150 x DN250	RH-A-101	0.20	0.55	121.0	11.0	360.0	14.37	2
	RH-A-102	0.55	0.85	125.0	13.5		14.14	2
	RH-A-103	0.85	1.35	122.0	14.0		10.40	2
	RH-A-105	1.35	1.80	123.0	16.0		11.42	2
	RH-A-190	1.80	2.30	120.0	16.0		9.70	2
	RH-A-107	2.30	2.90	120.0	17.5		10.69	2
	RH-A-108	2.90	4.20	119.0	18.0		10.27	2
	RH-A-110	4.20	5.60	121.0	19.0		9.60	2
	RH-A-111	5.60	7.20	132.0	20.5		8.56	2
	RH-A-113	7.20	9.10	146.2	22.4		7.70	2
	RH-A-114	9.10	11.60	155.0	23.5		6.81	2
	RH-A-116	11.60	14.60	155.0	24.5		6.25	2
	RH-A-119	14.60	16.00	155.2	26.4		6.77	2

## 7. To reset the safety valve

**Safety note:** It is essential to ensure that the desired set pressure is within the range of the spring fitted, see Section 5, SV60 spring identification chart.

- a) With the cap/lever components removed and the adjuster screw exposed the safety valve should be fitted to a suitable inert gas supply pressure source, such as compressed air. The pressure should be adjustable and measured using a gauge with an accuracy of within 0.5% of scale and subject to a regular calibration operation.
- b) Hold the valve spindle so that it cannot turn to prevent damage to the seating faces and turn the safety valve adjustment screw clockwise to compress the spring to an approximate set point (if the desired set point is near the higher end of the spring range then more compression is required and correspondingly less compression if near the lower end of the spring range).
- c) Slowly raise the pressure at a rate of approximately no more than 1 psi (0.07 bar) per second until the valve reaches the set point, the point at which the disc starts to leave the seat. This point can usually be judged audibly as a hissing noise.
- d) If the valve is set too high then reduce the pressure by about 30% and turn the adjuster screw anticlockwise. If the valve is set too low then turn the adjuster screw clockwise. It is essential to remember to hold the valve spindle to prevent it turning. Repeat these operations until desired set point is achieved and tighten the adjuster lock-nut at the recommended torque (see Table 1, page 3).
- e) Reduce the pressure and then once again gently raise the pressure to recheck the valve set point is correct.
- f) Replace the cap/lever assembly as described in previous text, fit the sealing wire and secure with lead seal to make the valve tamper-proof.
- g) If the set pressure has been changed from the original pressure ensure the new set pressure value is either indelibly marked or stamped on the valve or a separate stamped or engraved tag is permanently wired to the valve. The exact procedure for marking or stamping of the set pressure must comply with the latest codes and standards in force locally.