

M70i ISO and M80i ISO

Stainless Steel Ball Valves for Sanitary Systems

Installation and Maintenance Instructions

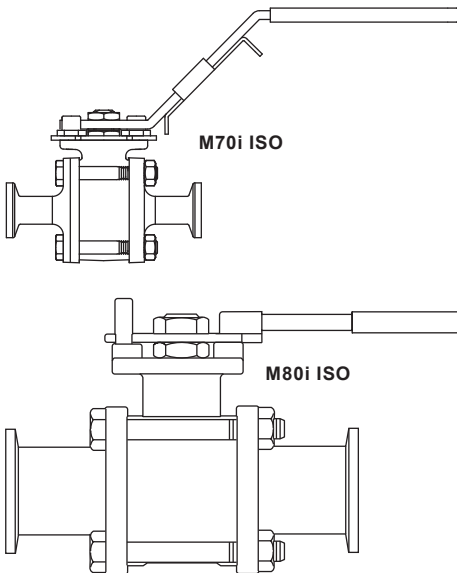

1. Safety information
2. General product information
3. Installation
4. Commissioning
5. Operation
6. Maintenance and spare parts

1. Safety information

Safe operation of these products can only be guaranteed if they are properly installed, commissioned, used and maintained by qualified personnel (see Section 1.11) in compliance with the operating instructions. General installation and safety instructions for pipeline and plant construction, as well as the proper use of tools and safety equipment must also be complied with.

1.1 Intended use

Referring to the Installation and Maintenance Instructions, name-plate and Technical Information Sheet, check that the product is suitable for the intended use/application. The products listed below comply with the requirements of the European Pressure Equipment Directive (PED) and carry the  mark when so required.

The products fall within the following Pressure Equipment Directive categories:

Product	Group 1 Gases	Group 2 Gases	Group 1 Liquids	Group 2 Liquids
M70i ISO and M80i ISO	1/2"	SEP	SEP	SEP
	3/4"	SEP	SEP	SEP
	1"	SEP	SEP	SEP
	1 1/2"	2	1	2
	2"	2	1	2
	2 1/2"	2	1	2
	3"	2	1	2
	4"	2	1	2

- i) The products have been specifically designed for use on clean/pure steam and other high purity applications that are in Group 2 of the above mentioned Pressure Equipment Directive.
- ii) Check material suitability, pressure and temperature and their maximum and minimum values. If the maximum operating limits of the product are lower than those of the system in which it is being fitted, or if malfunction of the product could result in a dangerous overpressure or overtemperature occurrence, ensure a safety device is included in the system to prevent such over-limit situations.
- iii) Determine the correct installation situation and direction of fluid flow.
- iv) Spirax Sarco products are not intended to withstand external stresses that may be induced by any system to which they are fitted. It is the responsibility of the installer to consider these stresses and take adequate precautions to minimise them.
- v) Remove protection covers from all connections and protective film from all name-plates, where appropriate, before installation on steam or other high temperature applications.

1.2 Access

Ensure safe access and if necessary a safe working platform (suitably guarded) before attempting to work on the product. Arrange suitable lifting gear if required.

1.3 Lighting

Ensure adequate lighting, particularly where detailed or intricate work is required.

1.4 Hazardous liquids or gases in the pipeline

Consider what is in the pipeline or what may have been in the pipeline at some previous time. Consider: flammable materials, substances hazardous to health, extremes of temperature.

1.5 Hazardous environment around the product

Consider: explosion risk areas, lack of oxygen (e.g. tanks, pits), dangerous gases, extremes of temperature, hot surfaces, fire hazard (e.g. during welding), excessive noise, moving machinery.

1.6 The system

Consider the effect on the complete system of the work proposed. Will any proposed action (e.g. closing isolation valves, electrical isolation) put any other part of the system or any personnel at risk?

Dangers might include isolation of vents or protective devices or the rendering ineffective of controls or alarms. Ensure isolation valves are turned on and off in a gradual way to avoid system shocks.

1.7 Pressure systems

Ensure that any pressure is isolated and safely vented to atmospheric pressure. Consider double isolation (double block and bleed) and the locking or labelling of closed valves. Do not assume that the system has depressurised even when the pressure gauge indicates zero.

1.8 Temperature

Allow time for temperature to normalise after isolation to avoid danger of burns.

If parts made from PTFE have been subjected to a temperature approaching 260 °C (500 °F) or higher, they will give off toxic fumes, which if inhaled are likely to cause temporary discomfort. It is essential for a no smoking rule to be enforced in all areas where PTFE is stored, handled or processed as persons inhaling the fumes from burning tobacco contaminated with PTFE particles can develop 'polymer fume fever'.

1.9 Tools and consumables

Before starting work ensure that you have suitable tools and/or consumables available. Use only genuine Spirax Sarco replacement parts.

1.10 Protective clothing

Consider whether you and/or others in the vicinity require any protective clothing to protect against the hazards of, for example, chemicals, high/low temperature, radiation, noise, falling objects, and dangers to eyes and face.

1.11 Permits to work

All work must be carried out or be supervised by a suitably competent person.

Installation and operating personnel should be trained in the correct use of the product according to the Installation and Maintenance Instructions.

Where a formal 'permit to work' system is in force it must be complied with. Where there is no such system, it is recommended that a responsible person should know what work is going on and, where necessary, arrange to have an assistant whose primary responsibility is safety.

Post 'warning notices' if necessary.

1.12 Handling

Manual handling of large and/or heavy products may present a risk of injury. Lifting, pushing, pulling, carrying or supporting a load by bodily force can cause injury particularly to the back. You are advised to assess the risks taking into account the task, the individual, the load and the working environment and use the appropriate handling method depending on the circumstances of the work being done.

1.13 Residual hazards

In normal use the external surface of the product may be very hot. If used at the maximum permitted operating conditions the surface temperature of these products may reach temperatures of 200 °C (392 °F).

These products are not self-draining. Take due care when dismantling or removing the product from an installation (refer to 'Maintenance instructions').

1.14 Freezing

Provision must be made to protect products which are not self-draining against frost damage in environments where they may be exposed to temperatures below freezing point.

1.15 Disposal

Unless otherwise stated in the Installation and Maintenance Instructions, this product is recyclable and no ecological hazard is anticipated with its disposal providing due care is taken, with the exception of PTFE.

PTFE:

- Can only be disposed of by approved methods, not incineration.
- Keep PTFE waste in a separate container, do not mix it with other rubbish, and consign it to a landfill site.

1.16 Returning products

Customers and stockists are reminded that under EC Health, Safety and Environment Law, when returning products to Spirax Sarco they must provide information on any hazards and the precautions to be taken due to contamination residues or mechanical damage which may present a health, safety or environmental risk. This information must be provided in writing including Health and Safety data sheets relating to any substances identified as hazardous or potentially hazardous.

2. General product information

2.1 General description

The M70i and M80i 316L stainless steel, three-piece body ball valves have ISO mounting as standard. They have been designed in accordance with ASME BPE for use on applications like liquids and gases utility and process support applications, such as clean steam*. These valves should be used as isolation valves, not as control valves.

ISO mounting

The integral ISO body mounting allows the valve to be automated without losing seal integrity, as the body does not require disassembly. Manual to remote control may therefore be easily accomplished by fitting a BVA 300 series pneumatic actuator available from Spirax Sarco. For further details contact Spirax Sarco.

Standards

These products fully comply with the requirements of the European Pressure Equipment Directive (PED) and carry the  mark when so required.

Certification

These products are available with the following certification:

- Material certification to EN 10204 3.1
- Elastomer FDA/USP compliance certificate.
- Surface finish certification.

Note:

All certification/inspection requirements must be stated at the time of order placement.

Available types

M70iV CF ISO	Virgin PTFE TFM 1600, with Cavity fillers
M70iVEP CF ISO	Virgin PTFE TFM 1600 electropolished to 0.375 micron Ra, with Cavity fillers
M70iG CF ISO	Mineral filled PTFE,with Cavity fillers
M70iGEP CF ISO	Mineral filled PTFE electropolished to 0.375 micron Ra, with Cavity fillers
M70iV ISO	Virgin PTFE TFM 1600
M70iVEP ISO	Virgin PTFE TFM 1600 electro-polished to 0.375 micron Ra
M70iG ISO	Mineral filled PTFE
M70iGEP ISO	Mineral filled PTFE electro-polished to 0.375 micron Ra
M80iVEP ISO	Virgin PTFE TFM 1600 electro-polished to 0.375 micron Ra
M80iVEP CF ISO	Virgin PTFE TFM 1600 electropolished to 0.375 micron Ra with Cavity fillers

2.2 Sizes and pipe connections

M70i	1/2", 3/4", 1", 1 1/2" and 2"	Sanitary clamp (ASME BPE)
		Extended O/D tube weld ends (ETO) (ASME BPE)
M80i	2 1/2", 3" and 4"	Sanitary clamp (ASME BPE)
		Extended O/D tube weld ends (ETO) (ASME BPE)

***Note:** Steam Service: For steam applications, cavity filler is not recommended

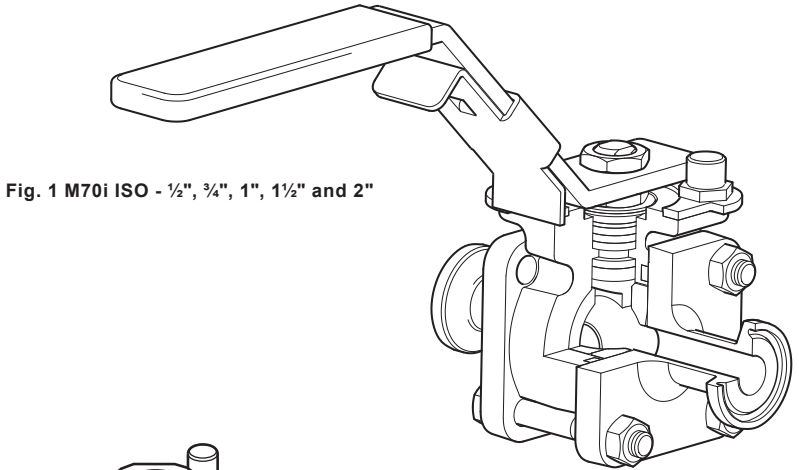
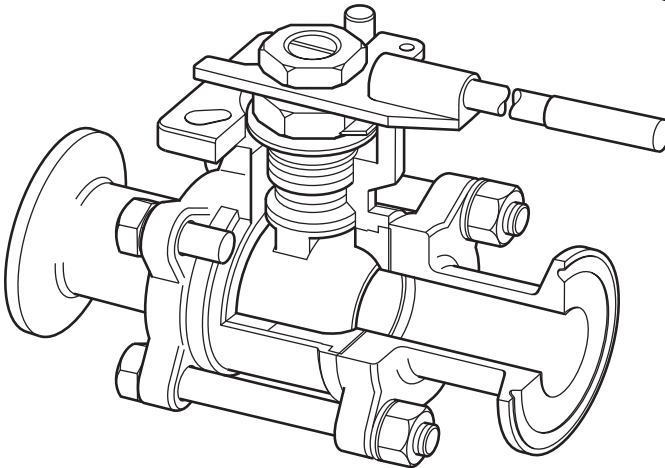

Fig. 1 M70i ISO - 1/2", 3/4", 1", 1 1/2" and 2"



Please note that the end caps for the 3" and 4" units have a different design which uses 6 x studs enclosing the body section.

Fig. 2 M80i ISO - 2 1/2", 3" and 4"

2.3 Pressure/temperature limits

M70i ISO

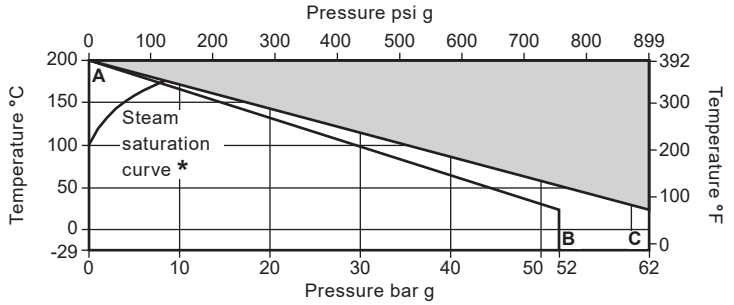

M80i ISO

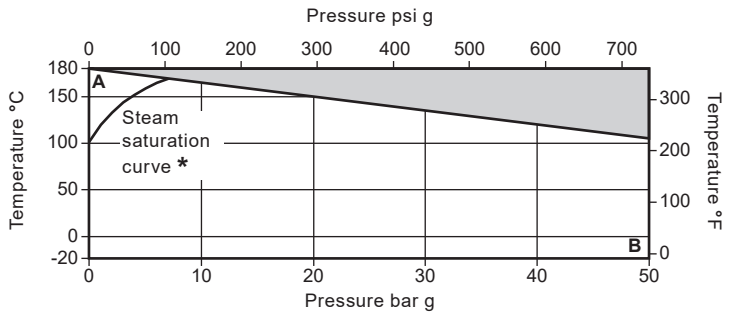

 The product **must not** be used in this region.

A - B Virgin PTFE TFM 1600.

A - C Mineral filled PTFE.

* **Note:** Steam Service: For steam applications, cavity filler is not recommended

Body design conditions		M70i		PN63
		M80i		720 psi g
PMA	Maximum allowable pressure	M70i	62 bar g @ 20 °C	(899 psi g @ 68 °F)
		M80i	50 bar g @ 109 °C	(720 psi g @ 228 °F)
TMA	Maximum allowable temperature	M70i	200 °C @ 0 bar g	(392 °F @ 0 psi g)
		M80i	180 °C @ 0 bar g	(356 °F @ 0 psi g)
Minimum allowable temperature		M70i	-29 °C	(-20 °F)
		M80i	-20 °C	(-4 °F)
PMO	Maximum operating pressure for saturated steam service *	M70i ISO	Virgin PTFE TFM 1600	7.0 bar g (101 psi g)
			Mineral filled PTFE	8.5 bar g (123 psi g)
		M80i ISO	Virgin PTFE TFM 1600	7.0 bar g (101 psi g)
TMO	Maximum operating temperature	M70i	200 °C @ 0 bar g	(392 °F @ 0 psi g)
		M80i	180 °C @ 0 bar g	(356 °F @ 0 psi g)
Minimum operating temperature		M70i	-29 °C	(-20 °F)
		M80i	-20 °C	(-4 °F)
Note: For lower operating temperatures consult Spirax Sarco.				
Δ PMX	Maximum differential pressure is limited to the PMO			
Designed for a maximum cold hydraulic test pressure of:		M70i	93 bar g	(1348 psi g)
		M80i	75 bar g	(1 087 psi g)

3. Installation

Note: Before actioning any installation observe the 'Safety information' in Section 1.

Although the valve has great structural integrity, severe misalignment and/or the pulling effect of incorrect pipe length will have a detrimental effect on the valve and must be avoided. Particular attention should be paid to correct pipe alignment such that the inlet and outlet pipework and valve are all on the same axis. Valves are for on/off applications and may be operated manually.

Valves should be installed where there is adequate space available so that they can be conveniently operated and maintained.

Before installing a valve, check to ensure that size, pressure rating, materials of construction, end connections, etc. are suitable for the service conditions of the particular application.

Care must be taken to ensure that all dirt which may have accumulated in the valve during storage is removed before installation, maintain cleanliness during installation since the introduction of dirt can result in damage to the valve seats and operating mechanism.

To minimise the danger of abrasive particles damaging the seats, pipeline strainers should be fitted upstream of the valves.

Install the valve with the handle in a suitable position. The preferred position is with the stem vertical and upwards. The valve can be installed in any position for gas service (see Figure 4).

When used on steam services:

(The alternative with Cavity filler is not recommended when used on steam service)

1. Fit a trapped drain pocket upstream of the valve.
2. Open valve slowly to prevent the risk of waterhammer damage.

Do not mount the valve upside down for liquid service (Figure 3).

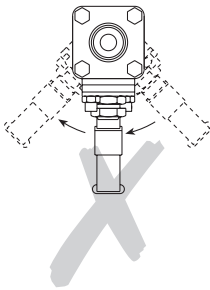

Fig. 3 Incorrect installation for liquid service

Valves should be installed into the pipeline in the fully closed position.

Caution:
Always open valves slowly to avoid system shocks.

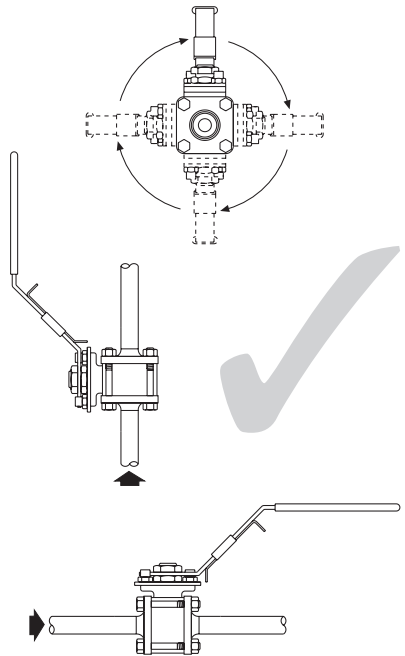

Fig. 4 Correct installation for gas service

4. Commissioning

After installation or maintenance ensure that the system is fully functioning. Carry out tests on any alarms or protective devices.

5. Operation

The valve is operated manually by a handle. Special care must be taken to ensure that the movement is made in the correct direction.

The valve can be used as an on/off valve, and can be operated fully open, or fully closed.

6. Maintenance and spare parts

Note: Before actioning any maintenance programme observe the 'Safety information' in Section 1.

6.1 General information

As with all mechanical devices, regular maintenance is the most efficient means of ensuring continued operational efficiency.

Regular scheduled inspection of all valves is essential, especially on valves which are operated only occasionally.

6.2 General maintenance

Maintenance work can be carried out without removing the complete ball valve from the pipeline. Remove the two upper nuts and bolts (see Table 1 for item no.) and loosen the lower two. The complete body assembly can then be removed and any new parts fitted - See Section 6.3 for the M70i ISO and Section 6.4 for the M80i ISO spare parts and maintenance instructions.

Table 1 Recommended tightening torques

Part	Item no.	Size	N m	(lbf ft)	
Nuts and bolts	14	M70i ISO	½" and ¾"	15	11.0
			1"	25	18.0
			1½"	57	42.0
	3	M80i ISO	2"	75	55.0
			2½"	80	60.0
			3"	90	66.5
Stem nut	10	M70i ISO	4"	130	97.0
			½" and ¾"	14	10.4
			1"	20	14.7
	17	M80i ISO	1½"	40	29.5
			2"	47	34.6
			2½"	42	30.5
			3"	42	30.5
			4"	51	37.0

6.3 Spare parts for the M70i ISO and maintenance instructions

6.3.1 Available spares

The spare parts available are shown in solid outline. Parts drawn in a grey line are not supplied as spares:

M70i ISO	Seat and seal set	5, 6, 16, 18
M70i CF ISO	Seat and seal set with cavity filler	5, 6, 15, 16, 18

How to order spares

Always order spares by using the description given in the column headed 'Available spares' and state the size and type of ball valve.

Example: 1 - Virgin PTFE TFM 1600 seat and seal set with cavity filler for a Spirax Sarco ½" M70i CF ISO forged stainless steel ball valve.

6.3.2 To replace seats and body gasket (and cavity fillers, if applicable)

- Remove the body as described in Section 6.2.
- With the body removed, remove the seats (**5**) and body gasket (**16**).
- Fit new seats (**5**) and body gasket (**16**), pushing them into the body recesses.

6.3.3 To replace stem seals

- Remove the body as described in Section 6.2.
- Make sure the valve is in Closed position
- Remove the stem nut (10)
- Remove the handle (12) and the lock washer (9)
- Remove the compression nut (8).
- Remove the Belleville washers (17) and the spacer (7)
- Remove the seats (5), body gasket (16) and Cavity fillers (15) if applicable.
- Remove the ball (3) by pushing it to any of the sides
- Remove the stem (4) by pushing it downwards towards the central chamber of the body (1)
- Replace the stem seals (6 and 18).

6.3.4 Reassembly

Reassemble in reverse order to the instructions given above. The securing bolts and nuts (14) should be tightened to the recommended torques shown in Table 1.

After 24 hours in service, retighten body bolts.

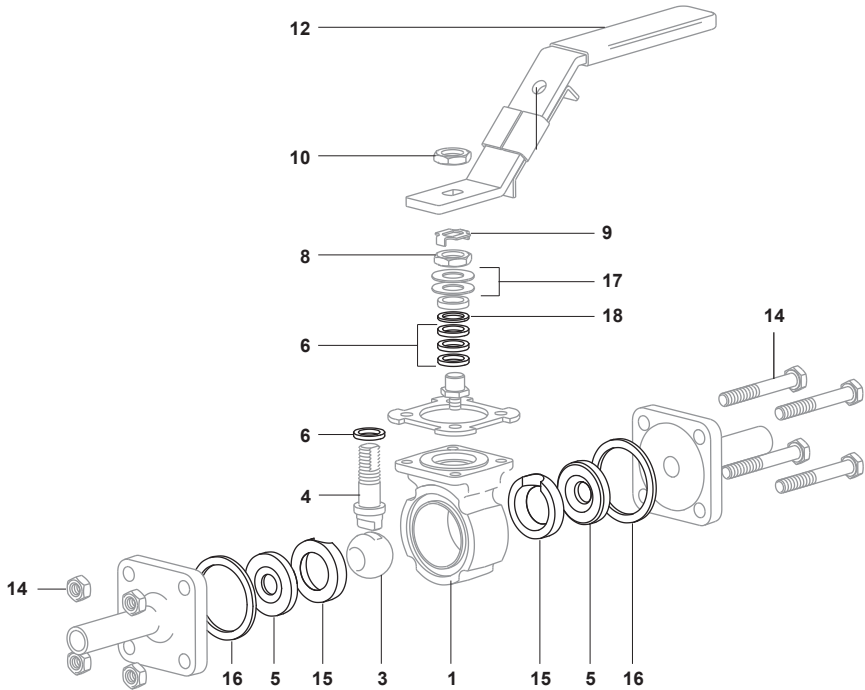

Fig. 5 M70i ISO Version with Cavity filler is shown

6.4 Spare parts for the M80i ISO and maintenance instructions

6.4.1 Available spares

The spare parts available are shown in solid outline. Parts drawn in a grey line are not supplied as spares:

M80i ISO	Seats, stem seals, stem 'O'ring, body seals kit, packing follower and thrust washer	5, 6, 11, 16, 18, 19
M80i CF ISO	Integrated seat and cavity filler, stem seals, stem 'O' ring, body seals kit, packing follower and thrust washer	5a, 6, 11, 16, 18, 19

How to order spares

Always order spares by using the description given in the column headed 'Available spares' and state the size and type of ball valve.

Example: 1 - Integrated seat and cavity filler, stem seals, stem 'O' ring, body seals kit, packing follower and thrust washer for a Spirax Sarco 4" M80iV ISO cast stainless steel ball valve.

6.4.2 To replace seats and body gasket

- Remove the body as described in Section 6.2.
- With the body removed, remove the seats (5) and body gasket (16).
- Fit new seats (5) and body gasket (16), pushing them into the body recesses.

6.4.3 To replace stem components

- Remove the body as described in Section 6.2.
- Make sure the valve is in Closed position
- Remove the stem nut (10)
- Remove the handle (12) and the lock washer (9)
- Remove the compression nut (8).
- Remove the Belleville washers (17) and the spacer (7)
- Remove the seats (5/5a) and body gasket (16).
- Remove the ball (3) by pushing it to any of the sides
- Remove the stem (4) by pushing it downwards towards the central chamber of the body (1)
- Replace the stem seals (6), stem 'O' ring (11), packing follower (18) and thrust washer (19).

6.4.4 Reassembly

Reassemble in reverse order to the instructions given above. The securing bolts and nuts (14) should be tightened to the recommended torques shown in Table 1, page 12.

After 24 hours in service, retighten body bolts.

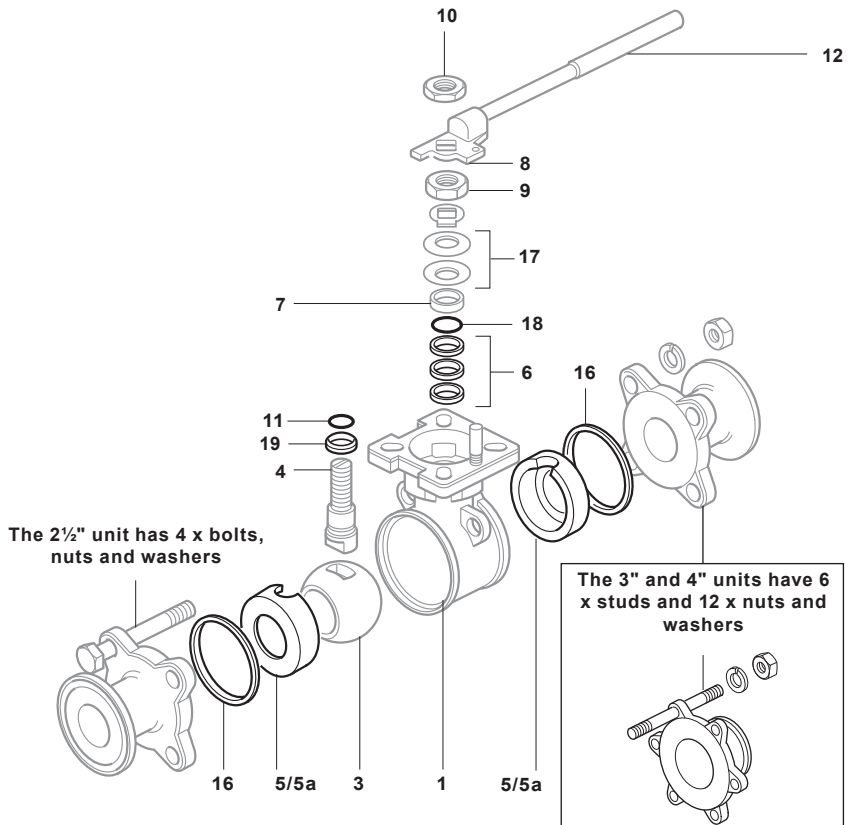

Fig. 7 M80i ISO

Note: The main spares drawing illustrates the 2½" unit. The same spares are available for the 3" and 4" units.

