

M20 Ball Valve

Installation and Maintenance Instructions

DN80 and DN150

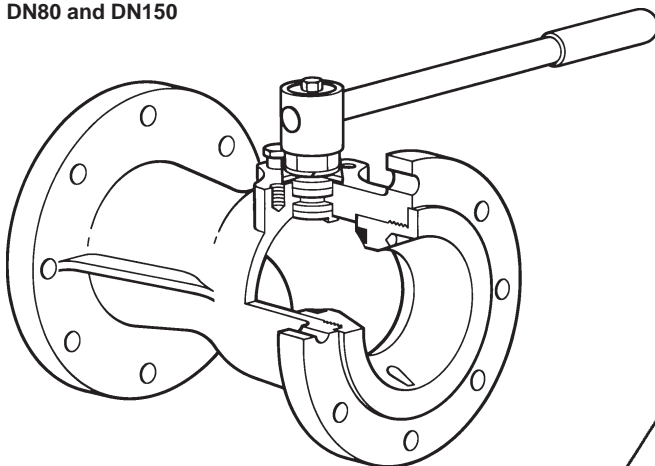

DN25 - DN65

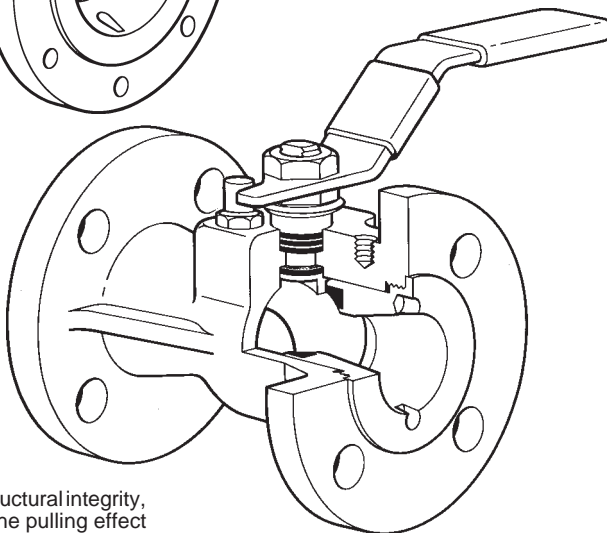

Installation

Although the valve has great structural integrity, severe misalignment and/or the pulling effect of incorrect pipe length will have a detrimental effect on the valve and must be avoided. Particular attention should be paid to correct pipe alignment such that the inlet pipework and valve are all on the same axis.

Valves are for on/off applications and may be installed with flow in either direction. When used on steam services:

1. Fit a trapped drain pocket upstream of the valve.
2. Open valve slowly to prevent the risk of waterhammer damage.

Safety note

Before commencing any dismantling work ensure that no flow is taking place in the pipeline; that the line is isolated elsewhere, or that the flow of the fluid is discontinued. Any fluid remaining in the line should be drained off before dismantling the valve.

Maintenance

General

When seats are replaced and the valve is reassembled it is advisable to conduct a hydraulic test to the body at:-

30 bar g for valves ANSI 150

75 bar g for valves ANSI 300

60 bar g for valves PN40

and a seat leakage test using compressed air at 7 bar g.

Dismantling the valve body

A special tool is required to remove the screw-in insert in order to dismantle the valve. The tool may be fabricated from a suitable thickness of plate (with rounded off edges) to fit into and across the counterbored holes in the insert. Considerable force may be required to 'break' the joint, and the use of a strong, rigidly mounted vice is a necessity. **DO NOT APPLY HEAT.**

Alternatively, the entire valve may be returned to Spirax Sarco for service exchange.

To replace main stem seals and seats.

WARNING:

If the old insert 'O' ring has been subjected to a temperature approaching 315°C or higher then it may have decomposed and formed hydrofluoric acid. Avoid skin contact and inhalation of any fumes as the acid will cause deep skin burns and damage the respiratory system. Further details about viton are available from Spirax Sarco in the form of an information sheet.

1. Remove valve from line (see safety note).
2. Using special tool - an example of which is available from Spirax Sarco, unscrew the insert (2). See warning.
3. It is now possible to remove the seats (4) and the ball. Withdraw the stem and replace the main stem seal (6A)
4. Reassemble using a new insert 'O' ring (8). See warning.
5. Ensure that a PTFE based sealant compound is applied to the insert thread.
6. The insert (2) should be tightened to the torques shown in the table opposite.

To replace secondary stem seals

1. Remove nuts (16 and 16A).

2. Replace stem seals (6: R-PTFE and 7: graphite).

Note: If leakage is observed through the stem it may be stopped by tightening gland nut (16A) without necessitating the replacement of stem seals.

The gland nut (16A) should be tightened to the torques shown in the table below.

Spare parts

The spare parts available are shown in heavy outline. Parts drawn in broken line are not supplied as spares.

Available spare

Seat, stem seals and gasket set **4, 6, 7, 8**

How to order spares

Always order spares by using the description given in the column headed Available Spare and stating the size and type of ball valve required.

Example: 1 - Seat and stem seal set for DN50 M20V2 ball valve.

Recommended tightening torques

Insert

Item	Size	N m
2	DN25 - DN32	108 - 135
	DN40	135 - 160
	DN50	215 - 245
	DN65	245 - 270
	DN80	405 - 605
	DN100	540 - 740
	DN150	1 000 - 1 200

Gland nut

Item	Size	N m
16A	DN25 - DN50	34 - 41
	DN65	41 - 47
	DN80 - DN100	54 - 61
	DN150	196 - 216

